



ISO Registered Company

## TECHNICAL BULLETIN

DA1-TB

02-20



# MODEL DA1

## DO-ALL SERIES I PRESSURE REDUCING REGULATOR



MODEL DA1

### OVERVIEW

The Model DA1 is a high performance, spring operated, flow-to-open, pressure reducing regulator with internal pressure balancing piston-cylinder that provides high flow capacity and high pressure drop capability. Internal trim design allows the same basic unit to cover a broad range of pressure settings. Performance approaches that of competitive pilot-operated designs in the basic construction. Applied primarily in clean gaseous or liquid services. Truly a "DO-ALL" pressure regulator.

### FEATURES

- Versatile:** Five basic materials and multiple trim material combinations to select from.
- Tight Shutoff:** Multiple composition materials provide Class IV or VI inboard leakage rates. Designed as a soft-seated valve.
- Capacity:** Highest in the industry. Allows smaller body sizes than competitors in a majority of applications.
- Pressure Drop:** Highest in the industry when coupled with high flow capacity.
- Trim Design:** "DO-ALL" trim design provides FTO and pressure balancing for higher inlet pressure. Results in unmatched sensitivity and stability. Internals are cage-contained within easily removable quick change trim.
- Rangeability:** Basic valve gives outstanding rangeability due to close tolerances, balanced trim, and a broad range of elastomeric diaphragms and soft seats. Can be as high as 1000:1.
- Heavy-Duty Guiding:** Both top and bottom guided to maintain stability and increased diaphragm life.
- Failure Position:** Fails open on loss of P<sub>1</sub> or P<sub>2</sub> pressures.

### APPLICATIONS

The "DO-ALL" design allows application of all types of clean fluids. Designed primarily for gaseous and liquid service applications where excessive cavitation is absent. Excellent for atmospheric industrial gases – GN<sub>2</sub>, GOX, Ar, He, H<sub>2</sub>, CO<sub>2</sub> – as well as a natural gas regulator. Used as a utilities – air, oil, water, steam – regulator. Corrosive and non-corrosive chemical services – gas or liquid – are possible with broad materials range. Special variations available for cryogenic gas; consult factory.



### LINE SIZES AVAILABLE

1/2" (DN15), 3/4" (DN20), 1" (DN25), 1-1/4" (DN32), 1-1/2" (DN40), 2" (DN50), 2-1/2" (DN65), 3" (DN80), 4" (DN100)



### END CONNECTIONS

NPT, FLANGED, BSPT, EXTENDED PIPE NIPPLES, 14" FACE TO FACE, EXTENSION TUBE ENDS



### COMMON APPLICATIONS

CLEAN FLUIDS, ATMOSPHERIC INDUSTRIAL GASES, NATURAL GAS, AIR, OIL, WATER, STEAM, CORROSIVE & NON-CORROSIVE CHEMICAL SERVICES



### DESIGN PRESSURE

INLET: 10-1480 psig (0.69-102.1 Barg)  
OUTLET: 1-450 psig (0.07-34.5 Barg)

## STANDARD / GENERAL SPECIFICATIONS

### Body / Spring Chamber Materials

DI/DI	BRZ/CS	SST/CS
CS/DI	BRZ/SST	SST/SST
CS/CS	HC/CS *	Dup SST/CS
BRZ/BRZ *	HC/SST *	Dup SST/SST
BRZ/DI	SST/DI	Dup SST/Dup SST

\* Through 2" (DN50) body size only.

DI = Ductile Iron CS = Carbon Steel BRZ = Bronze

SST = Stainless Steel HC = Hastelloy "C"

Dup SST = Super Duplex SST

### Body Sizes

1/2", 3/4", 1", 1-1/4", 1-1/2", 2", 2-1/2", 3", 4"  
(DN15, 20, 25, 32, 40, 50, 65, 80, 100)

### End Connections

Standard: Female NPT (screwed).

ASME Flanged: 125#, 150#, 250#, 300#, 600#

DIN Flanged: PN16, PN25, PN40;

Opt-31: British Standard Pipe Threads.

Opt-32: Schedule 80 Extended Pipe Nipples.

Opt-34: 14" Face to Face Flange Dimension.

Opt-41: Extension Tube Ends.

### Recommended Max. Useable Cv

Body Size		Diaphragm		Body Size		Diaphragm	
		Comp. Cv	Metal Cv			Comp. Cv	Metal Cv
in	(DN)			in	(DN)		
1/2"	(15)	3.6	3.5	2"	(50)	54	12
3/4"	(20)	7.2	3.5	2-1/2"	(65)	81	N/A
1"	(25)	13.5	3.5	3"	(80)	108	N/A
1-1/4"	(32)	20.7	6.0	4"	(100)	198	N/A
1-1/2"	(40)	27.0	6.0	-	-	-	-

See Table DAG-6 for Wide Open Cv Limits.

See Tables 3A through 3D and 4A through 4C for Cv vs. Droop vs. Range Spring tables.

**METRIC CONVERSION FACTOR:  $C_v / 1.16 = k_v$**

### Inlet Pressure Range

Operating: 10–1480 psig (.69–102.1 Barg).

See Tables DAG-1A – 1H for design P vs. T limits.

### Outlet Pressure Range

1/2"–1" (DN15–25):	1–450 psig (.07–34.5 Barg)
1-1/4"–1-1/2" (DN32–DN40):	1–400 psig (.07–27.6 Barg)
2" (DN50):	1–275 psig (.07–20.7 Barg)
2-1/2"–4" (DN65–100):	1–225 psig (.07–15.5 Barg)

**NOTE:** Ranges may be limited by diaphragm selection. See Table 5.

### Pressure Drop Limits

5–1480 psid (.34–102.1 Bard)

Function of service fluid, base trim material, diaphragm and dynamic seal design. See Table 5 and Table DAG-2, DAG-3 & DAG-4.

### Temperature Range

-425° to +400°F (-254° to +204° C)

Limited by body/sp.ch. material combinations, and by elastomeric – diaphragm, seat, static seal, dynamic seal – materials. See Tables DAG-1A through 1H and Table DAG-5.

Alternate "CS" Mat'l - Steel - ASTM A352 Gr. LCC -  
Minimum temperature -50 °F (-46 °C).

Cryogenic Application see Opt -5 or -36.

### Inboard Leakage Rates

See Table DAG-10

### Optional Constructions

<u>Opt-5:</u> Cryogenic Const.	<u>Opt-40:</u> NACE Const.
<u>Opt-9:</u> *TFE Diaph. Cover	<u>Opt-41:</u> Ext. Tube Ends
<u>Opt-25:</u> 1/4" (DN8) NPT Tap	<u>Opt-55:</u> Oxygen Cleaned
Spring Chmb.	<u>Opt-56:</u> Special Cleaned
<u>Opt-25S:</u> Vent Screen	<u>Opt-57:</u> Chlorine Cleaned
<u>Opt-30:</u> RF Flanges	<u>Opt-80:</u> High Outlet Press.
<u>Opt-31:</u> BSP End Conns.	<u>Opt-85:</u> Extra Set Pressure
<u>Opt-32:</u> Ext. Pipe Nipples	Taps
<u>Opt-34:</u> 14" F to F Flange.	
<u>Opt-36:</u> Cryogenic Const.	

\* Available with Composition Diaphragm ONLY.

### ABBREVIATIONS

FK = Fluorosilicone	NBR = Buna-N	PTFE = Polytetrafluoroethylene
FKM = Fluorocarbon	RTFE = Brz-fill TFE	V-TFE = Virgin TFE
EPR = Ethylene Propylene	GF-TFE = Glass-fill TFE	CTFE = Chlorotrifluoroethylene
BC = Neoprene	PA = PolyAll	3-ply (PTFE+FKM+PTFE)

## MATERIAL SPECIFICATIONS

### Body

- DI – ASTM A395  
CS – ASTM A216, Grade WCB  
     Alternate ASTM A352 Gr. LCC  
BRZ – ASTM B62, Alloy 83600,  
SST – ASTM A351, Grade CF3M.  
     Alternate ASTM A995/A995M7 Gr. 6A  
HC – ASTM A494, Gr. CW-12 MW.

See DAG-1A through DAG-1H for material specs.

### Spring Chamber

- DI – ASTM A395  
CS – Sizes 1/2" - 4" ASTM A216, Gr. WCB;  
     Alternate ASTM A352 Gr. LCC  
Opt-80 - Sizes 1/2"-1-1/2" ASTM A516, Gr. 55,  
     ASTM A106, Gr. B; Size 2" ASTM A216, Gr. WCB  
BRZ – ASTM B62, Alloy 83600.  
SST – Size 1/2" - 4 " ASTM A351 Gr. CF3M;  
Opt-80 - Size 1/2" - 1-1/2" ASTM A312, Gr. 316L,  
     ASTM A479, Gr. 316L; Size 2" is ASTM A351 Gr. CF3M  
     Alternate ASTM A995/A995M7 Gr. 6A

### Diaphragm \*

Elastomeric – BC, EP, FKM, FK, NBR, FKM+TFE,  
     3-ply (PTFE+FKM+PTFE).

Metallic – Be-Cu. (only 1/2" - 2" sizes)

### Metallic Trim \*

17-4PH SST, 316L SST, Nickel-Copper Alloy (Monel<sup>†</sup>),  
 See Table 2.

### Seat \*

PolyAll, V-TFE, GF-TFE, CTFE, BC, NBR, FKM

### Static Seals (See Fig. DAG-F1) \*

RTFE, NBR, FKM, FK, EP, - o-ring  
 SST/TFE (1/2"-2") (DN15-50) sizes,  
 V-TFE (2-1/2"-4") (DN65-100) sizes.

### Dynamic Seals (See Fig. DAG-F1) \*

- Type OR – NBR, FKM, FK, EP, - o-ring seal.  
Type UC – V-TFE u-cup seal w/ 316L SST energizer  
     – V-TFE u-cup seal w/ Elgiloy energizer  
     – V-TFE u-cup seal w/ Hast C energizer  
Type CW – TFE cap seal with o-ring energizer  
     (o-ring material same as static seal)  
     and GF-TFE wiper backup seal.  
Type PW – GF-TFE piston ring assembly seal with  
     17-7PH SST energizer and GF-TFE  
     wiper backup seal.

### Painting

Standard: All non-corrosion resistant portions to be painted  
 with corrosion resistant epoxy paint per Cashco Spec  
 #S-1606.

\* See Product Coder for acceptable combinations.  
 † Hastelloy<sup>®</sup>, Monel<sup>™</sup>, and Inconel<sup>®</sup> are registered trade  
 names:  
 Hastelloy<sup>®</sup> is a mark owned by Stelite Div., Cabot Corp.  
 Monel<sup>™</sup> is a mark owned by International Nickel Co.  
 Inconel<sup>®</sup> is a mark owned by International Nickel Co.

See Fig. DAG-1

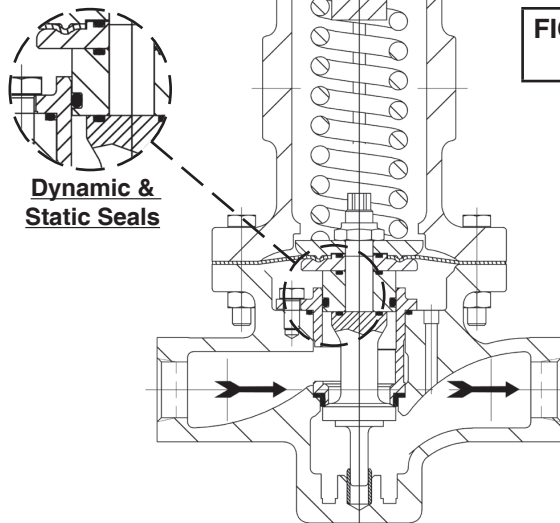

**Dynamic &  
 Static Seals**

**FIGURE 1 – Model DA1  
 Flow To Open**

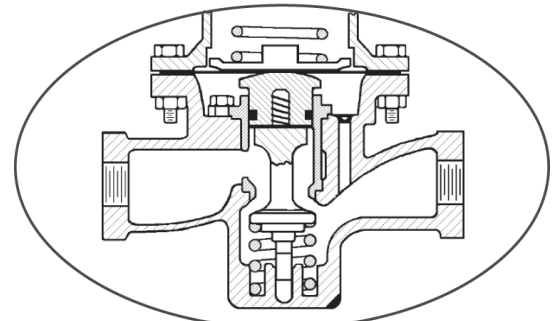

Composition Diaphragm

Metal Diaphragm

This construction REQUIRES a Lower Piston Spring to be supplied.

## OPTION SPECIFICATIONS

- OPT-5:** **BRZ CRYOGENIC CONSTRUCTION.** BRZ/BRZ body/spring chamber materials. NPT end connections. SN & TN trim selections only. Drilled condensate drain hole. **Select Opt-55 or Opt-56 for Special Cleaning.** Applicable temperature range -325° to +150° F. (-198° to +66° C). Design requires that spring chamber be mounted pointed downwards in a horizontal pipe.
- OPT-9:** **TFE DIAPHRAGM COVER.** A 0.020" (0.5 mm) thick TFE diaphragm is added to the selected diaphragm. TFE diaphragm cover is exposed to process fluid, providing added chemical compatibility. Use with composition diaphragm only.
- OPT-25:** **SPRING CHAMBER VENT TAP.** A 1/4" (DN8) - FNPT tap is located on spring chamber to allow for remote venting in case of diaphragm rupture. Primarily used when handling toxic or flammable fluids.
- OPT-25S:** **VENT SCREEN.** Cap (includes OPT-25).
- OPT-30:** **FLANGED END CONNECTIONS.** CS, SST or HC body materials only. All body sizes only (no 1-1/4" (DN32) size). Flange of same general chemistry as body. See Opt-34 for special 14" face to face dimension.  
**NOTES:** 1. The body P vs. T ratings are the limiting variables for flanged end connections, unless further restricted by ASME B16.5.
- OPT-31:** **BSPT END CONNECTIONS.** British Standard Pipe threads per ISO 7/1; used as an alternate to NPT ends. 1/2" – 2" (DN15–50) sizes only.
- OPT-32:** **EXTENDED PIPE NIPPLES.** Sch. 80 extension pipe nipples available for CS and SST bodies; for body sizes 1/2" – 2" (DN15–50) only.
- OPT-34:** **SPECIAL 14" FACE TO FACE DIMENSION FOR FLANGED END CONNECTIONS.** Sizes 1/2" - 1" & 1-1/2" only. See Opt.-30 for standard face to face dimension.
- OPT-36:** **SST CRYOGENIC CONSTRUCTION.** Same specification as Opt-5 except body/spring chamber material is SST/SST. (Be-Cu Diaphragm material.)
- OPT-40:** **NACE CONSTRUCTION.** Internal wetted portions meet NACE Std. MR0175 for application in sour gas/crude oil service. Exterior of unit to not be directly buried, insulated, or otherwise denied direct atmospheric exposure. CS/CS, LCC/LCC, LCC/SST, SST/CS, or SST/SST body/spring chamber materials only. 316L SST trim materials only. ELG/TFE U-cup dynamic seals. Available in all end connections.
- OPT-41:** **EXTENDED TUBE END CONN.** SST body material only. Body sizes 1/2"–1" (DN15–25), 1-1/2" & 2" (DN40–50) only. SST extension tube diameter with 0.065 inch (1.65 mm) wall thickness. NOT FOR HIGH PURITY REQUIREMENTS.
- OPT-55:** **SPECIAL CLEANING - GOX.** BRZ or SST body materials only. Cleaning, assembly and packaging per Cashco Spec #S-1134, making unit suitable for Oxygen Service. **NOTE: Design Pressure Rating shall not exceed 375 psig (25.8 Barg) when body material is SST and process medium is oxygen.**
- OPT-56:** **SPECIAL CLEANING.** Cleaning per Cashco Spec. #S-1542 for all body & spring chamber materials. Higher cleaning level than standard commercial cleaning. NOT suitable for Oxygen Service.
- OPT-57:** **SPECIAL CLEANING - Cl<sub>2</sub>.** CS, SST, or HC body materials only. Cleaning per Cashco Spec. #S-1589. For chlorine gas/liquid service.
- OPT-80:** **HIGH OUTLET PRESSURE.** Applies only to body sizes 1/2"–2" (DN15–50). Selecting highest available range spring requires special spring chamber construction. Only available as CS or SST spring chamber materials: Trims of P1, P2, P3, P4, P7, PB, M7, M9, NP, NV, T7 or T9 only.
- OPT-85:** **PRESSURE TAPS.** Provides second set of inlet and outlet 1/4" (DN8) - FNPT taps with plugs (same basic material as body) on backside of body. Includes second external sensing port tap. See page 22 for details on tap location for both STD. and Opt -85. **NOTE:** Not available for HC body.

## TECHNICAL SPECIFICATIONS

**TABLE 1  
RANGE SPRINGS**

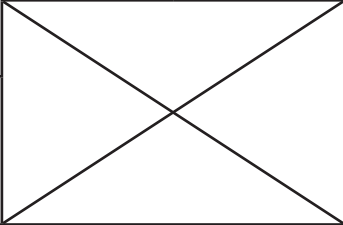
Body Size in. (DN)	Spring Range psig	Body Size in. (DN)	Spring Range psig
1/2" (15), 3/4" (20) 1" (25)	1-5 * 1-10 **	2" (50)	1-5 * 1-10 **
	5-20 10-35 20-80 30-150 70-200 100-300		5-15 10-30 15-50 30-90 50-150
	200-450 (Opt-80) ✓		80-225 80-275 (Opt-80)✓
	1-1/4" (32) 1-1/2" (40)	1-5 * 1-10 **	2-1/2" (65), 3" (80), 4" (100)
5-20 15-45 10-70 40-175 70-200		5-20 10-40 10-70 40-125 50-225	
100-350 100-400 (Opt-80) ✓			

\* Composition diaphragm construction ONLY.

\*\* Metal diaphragm for set point pressures  $\geq$  5 psig (.34 Barg).

✓ OPT-80 requires selection of a CS or SST spring chamber.

METRIC CONVERSION: psig / 14.5 = Barg.

**TABLE 2  
METALLIC TRIM MATERIAL COMBINATIONS**

PART	TRIM DESIGNATION				
	P	H	M	S	T
Plug	17-4 PH SST	Hastelloy-C	Monel†	316L SST	17-4 PH SST
Guide Bearing	17-4 PH SST	Hastelloy-C	Monel†	316L SST	17-4 PH SST
Cage	316L SST	Hastelloy-C	Monel†	316L SST	Monel†
Body Bushing	17-4 PH SST	Hastelloy-C	Monel†	Monel†	Monel†

† See Page 3 for registered trade name information.

**TABLE 3A  
FULL PORT FLOW CAPACITY – Cv  
COMPOSITION DIAPHRAGM  $F_L = 0.90$**

Pressure Setpoint Psp psig	Cv Capacity @ % Droop									Range Spring psig
	BODY SIZE - 1/2" (DN15)			BODY SIZE - 3/4" (DN20)			BODY SIZE - 1" (DN25)			
	10%	20%	30%	10%	20%	30%	10%	20%	30%	
1	1.08	2.00	2.70	1.35	2.50	3.38	1.51	2.79	3.76	1 - 5
3	3.06	3.24	3.42	4.05	6.48	6.84	4.51	8.34	11.25	
5	3.06	3.24	3.42	5.85	6.48	6.84	6.51	12.04	12.83	
1	0.52	0.96	1.29	0.66	1.22	1.65	0.71	1.31	1.76	1 - 10
5	3.06	3.24	3.42	3.29	6.09	6.84	4.31	7.97	10.75	
10	3.06	3.24	3.42	5.60	6.48	6.84	6.15	11.38	12.83	
5	2.16	3.24	3.42	2.71	5.01	6.76	3.00	5.55	7.49	5 - 20
10	3.06	3.24	3.42	4.28	6.48	6.84	4.75	8.79	11.87	
15	3.06	3.24	3.42	5.18	6.48	6.84	5.75	10.64	12.83	
20	3.06	3.24	3.42	6.12	6.48	6.84	8.35	12.15	12.83	10 - 35
10	1.04	1.92	2.59	1.31	2.42	3.26	1.45	2.68	3.61	
20	2.31	3.24	3.42	2.88	5.33	6.84	3.20	5.92	7.99	
30	3.06	3.24	3.42	4.68	6.48	6.84	5.20	9.62	12.83	
35	3.06	3.24	3.42	5.40	6.48	6.84	6.00	11.10	12.83	20 - 80
20	0.79	1.46	1.97	0.99	1.83	2.47	1.11	2.05	2.76	
40	1.33	2.46	3.32	1.67	3.09	4.17	1.85	3.42	4.61	
60	2.81	3.24	3.42	3.51	6.48	6.84	3.91	7.23	9.76	
80	3.06	3.24	3.42	4.91	6.48	6.84	5.45	10.08	12.83	30 - 150
30	0.72	1.33	1.79	0.91	1.68	2.26	1.00	1.85	2.50	
50	1.26	2.33	3.14	1.58	2.92	3.94	1.75	3.24	4.38	
75	2.16	3.24	3.42	2.71	5.01	6.76	3.00	5.55	7.49	
100	2.74	3.24	3.42	3.42	6.33	6.84	3.80	7.03	9.49	
125	3.06	3.24	3.42	4.51	6.48	6.84	5.00	9.25	12.49	
150	3.06	3.24	3.42	4.95	6.48	6.84	6.00	11.10	12.83	70 - 200
70	0.54	1.00	1.35	0.68	1.26	1.70	1.18	2.18	2.94	
100	1.73	3.20	3.42	2.16	4.00	5.41	2.40	4.44	5.99	
125	2.34	3.24	3.42	2.93	5.42	6.84	3.25	6.01	8.11	
150	2.74	3.24	3.42	3.42	6.33	6.84	3.80	7.03	9.49	
175	3.06	3.24	3.42	4.19	6.48	6.84	4.65	8.60	11.61	
200	3.06	3.24	3.42	5.04	6.48	6.84	4.71	8.71	11.75	100 - 300
100	0.80	1.48	2.00	0.72	1.33	1.79	0.80	1.48	2.00	
150	1.31	2.42	3.26	1.16	2.15	2.91	1.31	2.42	3.26	
200	1.75	3.24	3.42	1.44	2.66	3.58	1.65	3.05	4.11	
250	2.31	3.24	3.42	1.80	3.33	4.50	2.31	4.27	5.76	
300	3.00	3.24	3.42	2.15	3.98	5.38	3.00	5.55	7.49	200 - 450
200	2.35	3.24	3.42	2.82	5.22	6.84	3.29	6.09	8.23	
300	3.06	3.24	3.42	4.24	6.48	6.84	4.94	9.14	12.34	
400	3.06	3.24	3.42	5.65	6.48	6.84	6.59	12.15	12.83	
450	3.06	3.24	3.42	6.12	6.48	6.84	7.41	12.15	12.83	

METRIC CONVERSION FACTORS: psig / 14.5 = Barg;  $C_v / 1.16 = k_v$

**TABLE 3B**  
**FULL PORT FLOW CAPACITY – Cv**  
**COMPOSITION DIAPHRAGM  $F_L = 0.90$**

Pressure Setpoint Psp psig	Cv Capacity @ % Droop						Range Spring psig
	BODY SIZE 1-1/4" (DN32)			BODY SIZE 1-1/2" (DN40)			
	10%	20%	30%	10%	20%	30%	
1	2.09	3.87	5.23	2.20	4.07	5.49	1 - 5
3	4.75	8.79	11.87	5.00	9.25	12.49	
5	7.79	14.41	19.45	8.20	15.17	20.48	
1	1.01	1.87	2.53	1.04	1.92	2.59	1 - 10
5	4.60	8.51	11.49	4.85	8.97	12.11	
10	7.25	13.41	18.10	7.91	14.63	19.75	
5	2.66	4.92	6.64	2.80	5.18	6.99	5 - 20
10	5.71	10.56	14.25	6.00	11.10	14.99	
15	8.59	15.89	19.67	9.41	17.41	23.51	
20	11.41	18.63	19.67	11.77	21.77	25.65	15 - 45
15	4.46	8.25	11.14	4.71	8.71	11.75	
25	7.41	13.71	18.51	7.80	14.43	19.48	
35	10.31	18.63	19.67	10.91	20.18	25.65	10 - 70
45	13.41	18.63	19.67	15.06	24.30	25.65	
10	1.56	2.89	3.91	1.65	3.05	4.11	
30	4.27	7.90	10.67	4.51	8.34	11.25	40 - 175
50	7.36	13.63	18.39	7.75	14.34	19.36	
70	10.00	18.50	19.67	10.59	19.59	25.65	
40	2.56	4.74	6.41	2.71	5.01	6.76	70 - 200
50	3.80	7.03	9.49	4.00	7.40	9.99	
75	5.22	9.66	13.05	5.51	10.19	13.75	
100	6.88	12.73	17.19	7.25	13.41	18.10	100 - 350 (Opt-80)
125	8.55	15.82	19.67	9.00	16.65	22.48	
70	2.85	5.27	7.11	3.00	5.55	7.49	
100	4.65	8.60	11.61	4.91	9.08	12.25	50 - 150
125	5.36	9.92	13.40	5.65	10.45	14.10	
150	6.27	11.60	15.66	6.60	12.21	16.48	
175	7.12	13.17	17.78	7.51	13.89	18.75	80 - 275 (Opt-80)
200	8.74	16.17	19.67	9.20	17.02	22.98	
100	6.00	11.10	14.99	6.47	11.97	16.16	
200	11.29	18.63	19.67	11.77	21.77	25.65	100 - 350 (Opt-80)
300	16.94	18.63	19.67	17.65	24.30	25.65	
350	17.60	18.63	19.67	20.35	24.30	25.65	

**TABLE 3C**  
**FULL PORT FLOW CAPACITY – Cv**  
**COMPOSITION DIAPHRAGM  $F_L = 0.90$**

Pressure Setpoint Psp psig	Cv Capacity @ % Droop			Range Spring psig
	BODY SIZE 2" (DN50)			
	10%	20%	30%	
1	5.00	9.25	12.49	1 - 5
3	17.06	31.56	42.61	
5	27.53	48.60	51.30	
1	2.38	4.40	5.94	1 - 10
5	16.35	30.25	40.84	
10	26.00	48.10	51.30	
5	8.51	15.74	21.24	5 - 15
10	14.47	26.77	36.14	
15	22.35	41.35	51.30	
10	4.91	9.08	12.25	10 - 30
20	11.77	21.77	29.38	
30	17.65	32.65	44.07	
15	3.00	5.55	7.49	15 - 50
25	6.00	11.10	14.99	
35	8.71	16.11	21.74	
50	12.47	23.07	31.15	30 - 90
30	4.00	7.40	9.99	
60	8.20	15.17	20.48	
90	12.00	22.20	29.97	50 - 150
50	3.75	6.94	9.37	
75	6.00	11.10	14.99	
100	8.20	15.17	20.48	80 - 275 (Opt-80)
125	9.51	17.59	23.74	
150	12.47	23.07	31.15	
80	5.10	9.40	12.70	80 - 275 (Opt-80)
100	6.35	11.75	15.85	
200	12.70	23.50	31.70	
275	17.40	32.30	43.60	

**TABLE 3D**  
**FULL PORT FLOW CAPACITY – Cv** **COMPOSITION DIAPHRAGM  $F_L = 0.90$**

Pressure Setpoint Psp psig	Cv Capacity @ % Droop									Range Spring psig
	Body Size 2.5"			Body Size 3"			Body Size 4"			
	10%	20%	30%	10%	20%	30%	10%	20%	30%	
1	4.85	8.97	12.11	6.90	12.70	17.30	7.00	12.95	17.48	1 - 10
3	9.95	18.41	24.86	18.10	34.50	47.00	20.00	37.00	50.00	
5	21.18	39.18	52.89	29.06	53.76	72.58	35.06	64.86	89.00	
10	37.53	69.43	76.95	62.35	97.20	102.60	75.30	139.30	182.00	5 - 20
5	17.53	32.43	43.78	26.00	49.00	66.00	27.06	50.06	67.58	
10	30.00	55.50	75.00	44.50	81.20	104.00	45.06	83.36	112.00	
15	42.47	72.90	77.00	64.00	96.00	105.00	64.71	97.20	125.00	10 - 40
20	57.06	74.00	78.00	74.00	98.00	106.00	82.00	124.00	158.00	
10	17.53	32.43	43.78	25.00	45.00	62.00	25.06	46.36	63.00	
20	31.06	57.46	76.95	49.00	91.00	102.00	51.06	94.46	127.52	10 - 70
30	43.30	72.90	76.95	62.00	98.50	103.00	70.00	128.00	176.00	
40	60.00	72.90	76.95	94.00	102.00	105.00	104.00	178.20	191.00	
10	9.80	18.00	26.80	14.20	26.50	39.10	14.50	27.30	39.70	40 - 125
30	19.20	37.60	55.00	32.00	52.70	68.30	33.00	54.00	68.76	
50	40.20	69.40	79.50	47.00	88.00	103.00	48.00	89.67	121.06	
70	44.40	72.90	80.10	65.00	94.50	105.00	67.06	124.06	167.48	50 - 225
40	9.80	18.10	26.50	12.00	22.20	29.97	12.40	22.70	31.00	
50	12.57	23.70	37.00	17.06	31.56	42.61	17.30	32.00	43.20	
75	19.10	36.90	54.50	27.53	50.93	68.76	28.00	51.10	69.60	50 - 225
100	25.10	46.10	72.60	36.00	66.60	89.91	36.10	67.00	90.30	
125	31.00	57.80	79.30	42.47	78.57	104.00	43.90	79.20	118.00	
50	9.10	18.04	24.36	13.10	25.25	34.08	13.60	25.80	35.10	50 - 225
100	16.10	31.00	44.50	22.60	43.70	61.30	23.00	44.20	62.00	
150	24.10	45.20	63.00	31.50	59.40	88.20	32.00	60.50	89.00	
225	31.80	60.00	87.60	47.00	79.00	104.00	47.40	79.60	119.00	

METRIC CONVERSION FACTORS: psig / 14.5 = Barg;  $C_v / 1.16 = k_v$

**TABLE 4A**  
**FULL PORT FLOW CAPACITY – Cv**  
**METAL DIAPHRAGM  $F_L = 0.90$**

Pressure Setpoint Psp psig	Cv Capacity @ % Droop									Range Spring
	BODY SIZE - 1/2" (DN15)			BODY SIZE - 3/4" (DN20)			BODY SIZE - 1" (DN25)			
	10%	20%	30%	10%	20%	30%	10%	20%	30%	
5	1.24	2.30	3.10	1.32	2.44	3.29	1.72	3.15	3.33	1 - 10
10	1.66	3.06	3.33	2.24	3.15	3.33	2.46	3.15	3.33	
5	0.87	1.60	2.16	1.08	2.00	2.70	1.20	2.22	3.00	5 - 20
10	1.37	2.53	3.33	1.71	3.15	3.33	1.90	3.15	3.33	
15	1.66	3.06	3.33	2.07	3.15	3.33	2.30	3.15	3.33	
20	1.66	3.06	3.33	2.98	3.15	3.33	2.98	3.15	3.33	
10	0.41	0.77	1.03	0.52	0.97	1.30	0.58	1.07	1.45	10 - 35
20	0.92	1.71	2.30	1.15	2.13	2.88	1.28	2.37	3.20	
30	1.50	2.77	3.33	1.87	3.15	3.33	2.08	3.15	3.33	
35	1.60	2.96	3.33	2.16	3.15	3.33	2.40	3.15	3.33	
20	0.32	0.58	0.79	0.40	0.73	0.99	0.44	0.82	1.10	20 - 80
40	0.53	0.98	1.33	0.67	1.24	1.67	0.74	1.37	1.85	
60	1.12	2.08	2.81	1.40	2.59	3.33	1.56	2.89	3.33	
80	1.57	2.90	3.33	1.96	3.15	3.33	2.18	3.15	3.33	
30	0.29	0.53	0.72	0.36	0.67	0.90	0.40	0.74	1.00	30 - 150
50	0.50	0.93	1.26	0.63	1.17	1.57	0.70	1.30	1.75	
75	0.87	1.60	2.16	1.08	2.00	2.70	1.20	2.22	3.00	
100	1.10	2.03	2.74	1.37	2.53	3.33	1.52	2.81	3.33	
125	1.44	2.66	3.33	1.80	3.15	3.33	2.00	3.15	3.33	
150	1.59	2.93	3.33	1.98	3.15	3.33	2.40	3.15	3.33	
70	0.22	0.40	0.54	0.27	0.50	0.68	0.47	0.87	1.18	70 - 200
100	0.69	1.28	1.73	0.87	1.60	2.16	0.96	1.78	2.40	
125	0.94	1.73	2.34	1.17	2.17	2.93	1.30	2.40	3.24	
150	1.10	2.03	2.74	1.37	2.53	3.33	1.52	2.81	3.33	
175	1.34	2.48	3.33	1.68	3.10	3.33	1.86	3.15	3.33	
200	1.60	2.96	3.33	2.01	3.15	3.33	1.88	3.15	3.33	
100	0.32	0.59	0.80	0.29	0.53	0.72	0.32	0.59	0.80	100 - 300
150	0.52	0.97	1.30	0.47	0.86	1.16	0.52	0.97	1.30	
200	0.70	1.30	1.75	0.57	1.06	1.43	0.66	1.22	1.65	
250	0.92	1.71	2.30	0.72	1.33	1.80	0.92	1.71	2.30	
300	1.20	2.22	3.00	0.86	1.59	2.15	1.20	2.22	3.00	
200	0.94	1.74	2.35	1.13	2.09	2.82	1.32	2.44	3.29	
300	1.41	2.61	3.33	1.69	3.13	3.33	1.98	3.15	3.33	200 - 450 (Opt-80)
400	1.66	3.06	3.33	2.26	3.15	3.33	2.64	3.15	3.33	
450	1.66	3.06	3.33	2.54	3.15	3.33	2.96	3.15	3.33	

METRIC CONVERSION FACTORS: psig / 14.5 = Barg;  $C_v / 1.16 = K_v$



**TABLE 4B**  
**FULL PORT FLOW CAPACITY – Cv**  
**METAL DIAPHRAGM  $F_L = 0.90$**

Pressure Setpoint Psp psig	Cv Capacity @ % Droop						Range Spring psig
	BODY SIZE 1-1/4" (DN32)			BODY SIZE 1-1/2" (DN40)			
	10%	20%	30%	10%	20%	30%	
5	1.84	3.40	4.60	1.94	3.59	4.84	1 - 10
10	2.90	5.36	5.70	3.16	5.40	5.70	
5	1.06	1.97	2.66	1.12	2.07	2.80	5-20
10	2.28	4.22	5.70	2.40	4.44	5.70	
15	3.44	5.40	5.70	3.76	5.40	5.70	
20	4.56	5.40	5.70	4.71	5.40	5.70	
15	1.78	3.30	4.45	1.88	3.48	4.70	15 - 45
25	2.96	5.40	5.70	3.12	5.40	5.70	
35	4.12	5.40	5.70	4.36	5.40	5.70	
45	5.10	5.40	5.70	5.10	5.40	5.70	
10	0.63	1.16	1.56	0.66	1.22	1.65	10 - 70
30	1.71	3.16	4.27	1.80	3.33	4.50	
50	2.95	5.40	5.70	3.10	5.40	5.70	
70	4.00	5.40	5.70	4.24	5.40	5.70	
40	1.03	1.90	2.56	1.08	2.00	2.70	40 - 175
50	1.52	2.81	3.80	1.60	2.96	4.00	
75	2.09	3.87	5.22	2.20	4.07	5.50	
100	2.75	5.09	5.70	2.90	5.36	5.70	
125	3.42	5.40	5.70	3.60	5.40	5.70	
70	1.14	2.11	2.84	1.20	2.22	3.00	70 - 200
100	1.86	3.44	4.64	1.96	3.63	4.90	
125	2.15	3.97	5.36	2.26	4.18	5.64	
150	2.51	4.64	5.70	2.64	4.88	5.70	
175	2.85	5.27	5.70	3.00	5.40	5.70	
200	3.50	5.40	5.70	3.68	5.40	5.70	100 - 350 (Opt-80)
100	2.40	4.44	5.70	2.59	4.79	5.70	
200	4.52	5.40	5.70	4.71	5.40	5.70	
300	5.10	5.40	5.70	5.10	5.40	5.70	
350	5.10	5.40	5.70	5.10	5.40	5.70	

**TABLE 4C**  
**FULL PORT FLOW CAPACITY – Cv**  
**METAL DIAPHRAGM  $F_L = 0.90$**

Pressure Setpoint Psp psig	Cv Capacity @ % Droop			Range Spring psig
	BODY SIZE 2" (DN50)			
	10%	20%	30%	
5	6.54	10.80	11.40	1 - 10
10	10.20	10.80	11.40	
5	3.40	6.29	8.50	5 - 15
10	5.79	10.71	11.40	
15	8.94	10.80	11.40	
10	1.96	3.63	4.90	10 - 30
20	4.71	8.71	11.40	
30	7.06	10.80	11.40	
15	1.20	2.22	3.00	15 - 50
25	2.40	4.44	5.99	
35	3.48	6.44	8.70	
50	4.99	9.23	11.40	
30	1.60	2.96	4.00	30 - 90
60	3.28	6.07	8.19	
90	4.80	8.88	11.40	
50	1.50	2.78	3.75	50 - 150
75	2.40	4.44	5.99	
100	3.28	6.07	8.19	
125	3.80	7.03	9.50	
150	4.99	9.23	11.40	
80	2.10	3.80	5.00	80 - 275 (Opt-80)
100	2.60	4.75	6.25	
200	5.25	9.50	11.40	
275	7.20	11.30	11.40	

METRIC CONVERSION FACTORS: psig / 14.5 = Barg;  $C_v / 1.16 = k_v$

**TABLE 5**  
**MAXIMUM DIAPHRAGM RATING**

**NOTE:** The below ratings may be further "derated" by limitations through the Pressure Equipment Directive (2014/68/EU).

Diaphragm Material	Standard Diaphragm Construction psig (Barg) *	
	Body Size in (DN)	
	1/2" – 2" (15–50)	2-1/2" – 4" (65–100)
BC, EPR	1250 (86.1)	800 (55.1)
NBR	450 (31.0)	300 (20.6)
FKM, FKM+TFE, FK	700 (48.2)	550 (37.9)
3-ply (PTFE+FKM+PTFE) **	125 (8.6)	125 (8.6)
Metal (Be-Cu)	1500 (103)	N/A

\* Maximum setting of pressure safety device – safety relief valve or rupture disc.

\*\* For Steam applications.

NA = Not Available

## DAG TECHNICAL APPENDIX INDEX

<b>TABLE</b>	<b>TITLE</b>	<b>PAGE</b>
DAG-1A	DI – Press vs Temp vs End Conn Ratings	10
DAG-1B	BRZ – Press vs Temp vs End Conn Ratings	11
DAG-1C	CS – Press vs Temp vs End Conn Ratings - Design Inlet	12
DAG-1D	Design Outlet - DA1	12
DAG-1E	SST – Press vs Temp vs End Conn Ratings – Design Inlet	13
DAG-1F	Design Outlet - DA1	13
DAG-1G	HC – Press vs Temp vs End Conn Ratings – Design Inlet	14
DAG-1H	Design Outlet - DA1	14
DAG-2	Max Pressure Drop - Comp Seat	15
DAG-3	Max Pressure Drop - Dynamic Seal Design	15
DAG-4	Max Pressure Drop - Basic Trim Mat'ls	15
DAG-5	Temperature Limits – Elastomer Mat'ls	16
DAG-6	Reducer Max Capacity - Plug Wide Open	17
DAG-9	Reducer Lower Piston Spring range	17
DAG-10	Inboard Leakage Ratings	18
DAG-11	Reducer Recommended Velocity Limits	18
DAG-13	Max Recommended Noise Limits	18
DAG-14	Recommended Internal Materials - Liquids	19
DAG-14	Recommended Internal Materials - Gases	19
DAG-14	Supplement - Chemical Resistance	20
DAG-15	ISR Effect	20
<b>FIGURE</b>		
DAG-F1	Dynamic/Static Seals	21
DAG-F2	Location of Body/Spring Chamber Taps	22

**TABLE DAG-1A**  
**DI – DUCTILE IRON**  
**BODY / TOPWORKS MATERIAL SPECIFICATIONS**  
**DESIGN PRESSURE vs. TEMPERATURE vs. END CONNECTION RATINGS**  
**(To ASME B16.1 for Flanged and B16.4 for NPT Connections per Cast Iron Rating)**

Material Specifications (Body / Topworks)		End Connection – Inlet & Outlet					
		Temperature °F	Working Pressure – psig				
Description (Abbr.)	ASTM No.		End Connection – Pressure Class				
			NPT	125# FF	250# RF		
DI/DI (Note 1)	A395/ A395	-20° to +150°	400	200	500		
		200°	370	190	460		
		225°	355	180	440		
		250°	340	175	415		
		300°	310	165	375		
		350°	300	150	335		
		400°	250	140	290		
		406°	250	140	290		
			400 WOG, 250 S	225 WOG, 125 S	400 WOG, 250 S		
		Temperature °C		Working Pressure – Barg			
				End Connection – Pressure Class			
				NPT	125# FF	250# RF	
				-29° to +65°	27.6	13.8	34.5
				107	24.5	12.5	30.2
				120°	23.4	12.1	28.7
150°	21.2			11.2	25.7		
177°	19.2			10.6	23.8		
204°	17.5	9.6	20.3				

**NOTE 1:** Whenever body and topworks materials are mixed, the P vs. T ratings that should be applied are those which are lowest of the two materials.

**Example:** CS body, DI topworks; NPT end connections, 200°F temperature.

Because the topworks is not “end flanged”, use the DI limits of "400 PSIG CWP 370/200F" from above to compare to CS limits from DAG-1C values. The DI limits are lower, so ratings from DAG-1A MUST be used as the limits.

**NOTE 2:** Unless stated otherwise, design pressure is Maximum Allowable Working Pressure (MAWP) for Inlet and Outlet.

**TABLE DAG-1B  
BRZ – BRONZE  
BODY / TOPWORKS MATERIAL SPECIFICATIONS**

**DESIGN PRESSURE vs. TEMPERATURE vs. END CONNECTION RATINGS  
(Per ASME B16.24 for Flanged and B16.15 for NPT Connections)**

Material Specifications (Body / Topworks)		End Connection – Inlet & Outlet (Note 2)				
Description (Abbr.)	ASTM No.	Temperature °F	Working Pressure –psig			
			End Connection – Pressure Class			
			NPT	150# FF	300# FF	
BRZ/BRZ (Note 1)	B62, Alloy C83600/B62, Alloy C83600	-325° to +150° *	700 † / 500	225	500	
		175°	390	220	480	
		200°	385	210	465	
		225°	375	205	445	
		250°	365	195	425	
		300°	335	180	390	
		350°	300	165	350	
		400°	250	150	315	
		406°	250	150	315	
		Temperature °C	Working Pressure – Barg			
			End Connection – Pressure Class			
			NPT	150# FF	300# FF	
			-198° to +65° *	48.3 † / 34.5	15.5	34.5
			107°	25.8	14.0	30.8
			120°	25.1	13.5	29.5
			150°	23.0	12.4	26.8
			177°	20.4	11.3	24.0
			204°	17.8	10.3	21.4

**NOTE 1:** Whenever body and topworks materials are mixed, the P vs. T ratings that should be applied are those which are lowest of the two materials.

**Example:** BRZ body, DI topworks; NPT end connections, ambient temperature.  
Because the topworks is not “end flanged”, use the DI limits of "400 PSIG CWP 370/200F" from DAG-1A to compare to above DAG-1B values. The DI limits are lower, so ratings from DAG-1A MUST be used as the limits.

**NOTE 2:** Unless stated otherwise, design pressure is Maximum Allowable Working Pressure (MAWP) for Inlet and Outlet.

† **For Pressure Reducing Regulator DA1** use 700 psig (48.2 Barg) inlet / 500 psig (34.4 Barg) outlet at 150°F as maximum limits.

\* See Minimum Temperature Ratings Table below.

**DESIGN PRESSURE RATING  
AT MIN. TEMPERATURE**

Regulator Function	Material Specifications (Body / Topworks - Connections) Description (Abbr.)	Pressure at Min. Temperature
Pressure Reducing	BRZ/BRZ - NPT	Inlet - 700 psig CWP to -325°F (-198°C)
		Outlet - 500 psig CWP to -325°F (-198°C)
	SST/SST - NPT, BSP, Ext. Nipples, Tube Ends and 600# Flgs	Inlet - 1440 psig CWP to -425°F (-254°C)
		Outlet - 625 psig CWP to -425°F (-254°C)

### Body Material Specifications

**Cast Steel** A216 Gr. WCB or Steel Weldment A216 Gr. WCB w/ forged flanges A105

**Alternate Material:** Cast Steel A352 Gr. LCC or Steel Weldment A352 Gr. LCC w/ forged flanges A350 Gr. LF6 Class 2

### Topworks Material Specifications

**Cast Steel** A216 Gr. WCB.

(For Option-80 Sizes 1/2"-1-1/2" Steel Weldment A516 Gr. 55 & A106; Size 2" ASTM A216, Gr. WCB)

**Alternate Material:** Cast Steel A352 Gr. LCC

### DESIGN PRESSURE vs. TEMPERATURE vs. END CONNECTION RATINGS

(Per ASME B16.5 and B16.34) See NOTE 1

<b>TABLE DAG-1C</b>				
<b>DESIGN INLET PRESSURE FOR DA1</b>				
<b>in PSIG (BARG)</b>				
<b>CONSTRUCTION</b>	<b>END CONNECTIONS</b>			
<b>DESIGN TEMP. RANGE: Deg F (Deg C) **</b>	<b>NPT, BSP</b>	<b>600#, EXTD NIPP</b>	<b>150#</b>	<b>300#</b>
-20 to +100 (-29 to +38)	1480 (102.1)	1480 (102.1)	285 (19.6)	740 (51.1)
-20 to +200 (-29 to +93)	1360 (94.2)	1360 (94.2)	260 (17.9)	680 (47.1)
-20 to +300 (-29 to +149)	1310 (90.3)	1310 (90.3)	230 (15.8)	655 (45.1)
-20 to +400 (-29 to +204)	1265 (87.3)	1265 (87.3)	200 (13.7)	635 (43.6)

\*\* Alternate Mat'l: ASTM 352 Gr. LCC Minimum Temperature -50 °F (-46 °C).

<b>TABLE DAG-1D</b>			
<b>DESIGN OUTLET PRESSURE FOR DA1</b>			
<b>in PSIG (BARG)</b>			
<b>CONSTRUCTION</b>	<b>END CONNECTIONS</b>		
<b>DESIGN TEMP. RANGE: Deg F (Deg C) **</b>	<b>NPT, BSP, 600#, EXTD NIPP</b>	<b>150#</b>	<b>300#</b>
-20 to +100 (-29 to +38)	750 (51.7)	285 (19.6)	740 (51.1)
-20 to +200 (-29 to +93)	680 (47.1)	260 (17.9)	680 (47.1)
-20 to +300 (-29 to +149)	655 (45.1)	230 (15.8)	655 (45.1)
-20 to +400 (-29 to +204)	635 (43.6)	200 (13.7)	635 (43.8)

\*\* Alternate Mat'l: ASTM 352 Gr. LCC Minimum Temperature -50 °F (-46 °C).

**NOTE 1:** These pressure ratings may be further derated by limitations through the Pressure Equipment Directive (2014/68/EU). Whenever body and topworks are mixed, the P vs. T ratings that should be applied are those which are lowest for the two materials.

**Example:** 600 lb. RF flanged steel body at 200 deg F maximum temp would have a preliminary inlet to 1360 psig and outlet to 680 psig, but if fitted with a ductile iron topworks pressure rating is only 370 psig. Must derate both the inlet and outlet to 370 psig. (Note: Topworks pressure rating, same as NPT design outlet pressure rating for the selected topworks material and diaphragm type.)

### Body Material Specifications

**Cast Stainless Steel** A351 Gr.CF3M or Stainless Steel Weldment A315 Gr. CF3M w/ forged flanges A182 Gr. F 316L

**Alternate Material:** Super Duplex SST A995/A995M Gr. 6A

### Topworks Material Specifications

**Cast Stainless Steel** A351 Gr.CF3M.

(For Option-80 Sizes 1/2"-1-1/2" Stainless Steel Weldment A312 Gr. 316/316L, A479 Gr. 316/316L, Size 2" is ASTM A351 Gr. CF3M)

**Alternate Material:** Super Duplex SST A995/A995M Gr. 6A

### DESIGN PRESSURE vs. TEMPERATURE vs END CONNECTION RATINGS

(Per ASME B16.5 and B16.34) See NOTE 1

<b>TABLE DAG-1E</b>				
<b>DESIGN INLET PRESSURE FOR DA1</b>				
<b>in PSIG (BARG)</b>				
<b>CONSTRUCTION</b> *	<b>END CONNECTIONS</b>			
<b>DESIGN TEMP. RANGE: Deg F (Deg C) **</b>	<b>NPT, BSP</b>	<b>600#, EXTD NIPP, TUBE</b>	<b>150#</b>	<b>300#</b>
-425 to +100 (-254 to +38)	1440 (99.3)	1440 (99.3)	275 (19.0)	720 (49.6)
-20 to +200 (-29 to +93)	1240 (86.1)	1240 (86.1)	235 (16.5)	620 (43.0)
-20 to +300 (-29 to +149)	1120 (77.1)	1120 (77.1)	215 (14.8)	560 (38.6)
-20 to +400 (-29 to +204)	1025 (70.9)	1025 (70.9)	195 (13.6)	515 (35.5)

\*\* *Alternate Mat!*: ASTM 995 / 995M Gr. 6A Super Duplex SST  
Minimum Temperature -60 °F (-51 °C).

<b>TABLE DAG-1F</b>			
<b>DESIGN OUTLET PRESSURE FOR DA1</b>			
<b>in PSIG (BARG)</b>			
<b>CONSTRUCTION</b> *	<b>END CONNECTIONS</b>		
<b>DESIGN TEMP. RANGE: Deg F (Deg C) **</b>	<b>NPT, BSP, 600#, EXTD NIPP, TUBE</b>	<b>150#</b>	<b>300#</b>
-425 to +100 (-254 to +38)	625 (43.0)	275 (19.0)	625 (43.0)
-20 to +200 (-29 to +93)	620 (42.3)	235 (16.5)	620 (42.3)
-20 to +300 (-29 to +149)	560 (38.6)	215 (14.8)	560 (38.6)
-20 to +400 (-29 to +204)	515 (35.5)	195 (13.6)	515 (35.5)

\*\* *Alternate Mat!*: ASTM 995 / 995M Gr. 6A Super Duplex SST  
Minimum Temperature -60 °F (-51 °C).

\* For Temperatures below -20°F - refer to page 11 for Design Pressure Rating at Min. Temperature.

**NOTE 1:** These pressure ratings may be further derated by limitations through the Pressure Equipment Directive (2014/68/EU). Whenever body and topworks are mixed, the P vs. T ratings that should be applied are those which are lowest for the two materials.

**Example:** 300 lb. RF flanged SST body at 200 deg F maximum temp would have a preliminary inlet and outlet to 620 psig, but if fitted with a ductile iron topworks pressure rating is only 400 psig. Must derate both the inlet and outlet to 400 psig. (Note: Topworks pressure rating, same as NPT design outlet pressure rating for the selected topworks material and diaphragm type.

The ratings are the same as above, if substitute steel topwork material.

Maximum Design Pressure Rating for 2" Opt -41 limited by 0.065" wall thickness to 1200 psig.

300# Flanges are derated due to the bolting for these products.

### Body Material Specifications

**Cast Hastelloy** A494 Gr. CW-12MW or Hastelloy Weldment A494 Gr. CW-12MW w/ forged flanges B462 Gr. N10276

### Topworks Material Specifications

Cast Steel A216 Gr. WCB. (For Option-80 Steel Weldment A516 Gr. 55 & A106)

### DESIGN PRESSURE vs. TEMPERATURE vs END CONNECTION RATINGS

(Per ASME B16.5 and B16.34) See NOTE 1

<b>TABLE DAG-1G</b>			
<b>DESIGN <u>INLET</u> PRESSURE FOR DA1</b>			
<b>in PSIG (BARG)</b>			
<b>CONSTRUCTION</b>	<b>END CONNECTIONS</b>		
<b>DESIGN TEMP. RANGE: Deg F (Deg C)</b>	<b>NPT, BSP</b>	<b>150#</b>	<b>300#</b>
-325 to +100 (-198 to +38)	1200 (82.7)	230 (15.9)	600 (41.4)
-20 to +200 (-29 to +93)	1105 (76.4)	210 (14.7)	550 (38.2)
-29 to +300 (-29 to +149)	1040 (71.8)	200 (13.7)	520 (35.9)
-20 to +400 (-29 to +204)	980 (67.6)	190 (12.9)	490 (33.8)

<b>TABLE DAG-1H</b>			
<b>DESIGN <u>OUTLET</u> PRESSURE FOR DA1</b>			
<b>in PSIG (BARG)</b>			
<b>CONSTRUCTION</b>	<b>END CONNECTIONS</b>		
<b>DESIGN TEMP. RANGE: Deg F (Deg C)</b>	<b>NPT, BSP</b>	<b>150#</b>	<b>300#</b>
-325 to +100 (-198 to +38)	625 (43.0)	230 (15.9)	600 (41.4)
-20 to +200 (-29 to +93)	550 (38.2)	210 (14.7)	550 (38.2)
-20 to +300 (-29 to +149)	520 (35.9)	200 (13.7)	520 (35.9)
-20 to +400 (-29 to +204)	490 (33.8)	190 (12.9)	490 (33.8)

**NOTE 1:** These pressure ratings may be further derated by limitations through the Pressure Equipment Directive (2014/68/EU).

**TABLE DAG-2  
MAXIMUM PRESSURE DROP FOR  
COMPOSITION SEATS**

Body Size		Max. Pressure Drop - psid (Bard)										
		Seat Material										
in	(DN)	BC, NBR, POLYALL *, FKM					GF-TFE					
		Liquid *		Gas		Steam	Liquid *		Gas		Steam √	
1/2" – 1"	(15-25)	600	(41.3)	750	(51.7)	DNA	450	(31.0)	1000	(68.9)	150/125	(10.3/8.6)
1-1/4" – 1-1/2"	(32-40)	600	(41.3)	600	(41.3)	DNA	450	(31.0)	900	(62.0)	150/125	(10.3/8.6)
2"	(50)	600	(41.3)	600	(41.3)	DNA	450	(31.0)	750	(51.7)	150/125	(10.3/8.6)
2-1/2" – 4"	(65-100)	500	(34.4)	600	(41.3)	DNA	450	(31.0)	750	(51.7)	125	(8.6)
		V-TFE					CTFE					
1/2" – 1"	(15-25)	300	(20.7)	600	(41.3)	125	(8.6)	600	(41.3)	3000	(206.9)	DNA
1-1/4" – 1-1/2"	(32-40)	300	(20.7)	600	(41.3)	125	(8.6)	600	(41.3)	3000	(206.9)	DNA
2"	(50)	300	(20.7)	600	(41.3)	125	(8.6)	600	(41.3)	2000	(137.9)	DNA
2-1/2" – 4"	(65-100)	300	(20.7)	450	(31.0)	125	(8.6)	500	(34.4)	1500	(103.4)	DNA

\* Only seat material to be applied in liquid "partially cavitating" service is PolyAll.  
√ Steam Service: metal diaphragm/composition diaphragm.  
N/A = Not Available  
DNA = Do Not Apply

**TABLE DAG-3  
MAXIMUM PRESSURE DROP FOR  
DYNAMIC SEAL DESIGNS**

Body Size		Max. Pressure Drop - psid (Bard)														
		Dynamic Seal Design														
in	(DN)	"OR" – O-RING *					"CP" – TFE CAP					"CW" – TFE CAP w/WIPER				
		Liquid *		Gas *		Steam	Liquid		Gas		Steam	Liquid		Gas		Steam
1/2" – 1"	(15-25)	600	(41.3)	750	(51.7)	DNA	600	(41.3)	600	(41.3)	DNA	450	(31.0)	600	(41.3)	DNA
1-1/4" – 1-1/2"	(32-40)	600	(41.3)	750	(51.7)	DNA	600	(41.3)	600	(41.3)	DNA	450	(31.0)	600	(41.3)	DNA
2"	(50)	600	(41.3)	750	(51.7)	DNA	600	(41.3)	600	(41.3)	DNA	450	(31.0)	600	(41.3)	DNA
2-1/2" – 4"	(65-100)	600	(41.3)	750	(51.7)	DNA	600	(41.3)	600	(41.3)	DNA	450	(31.0)	600	(41.3)	DNA
		"PR" – PISTON RING ASSY.					"PW" – PISTON RING ASSY. w/WIPER					"UC" – U-CUP				
1/2" – 1"	(15-25)	DNA	DNA	√ 150/125	(10.3/8.6)	DNA	DNA	√ 150/125	(10.3/8.6)	600	(41.3)	3000	(206.9)	DNA		
1-1/4" – 1-1/2"	(32-40)	DNA	DNA	√ 150/125	(10.3/8.6)	DNA	DNA	√ 150/125	(10.3/8.6)	600	(41.3)	3000	(206.9)	DNA		
2"	(50)	DNA	DNA	√ 150/125	(10.3/8.6)	DNA	DNA	√ 150/125	(10.3/8.6)	600	(41.3)	3000	(206.9)	DNA		
2-1/2" – 4"	(65-100)	DNA	DNA	125	(8.6)	DNA	DNA	125	(8.6)	600	(41.3)	3000	(206.9)	DNA		

\* Only seat material to be applied in liquid "partially cavitating" or "flashing" service is PolyAll.  
√ Steam Service: metal diaphragm/composition diaphragm.  
N/A = Not Available      DNA = Do Not Apply      wo/ = without      w/ = with

**TABLE DAG-4  
MAXIMUM PRESSURE DROP FOR  
BASIC TRIM MATERIAL**

Body Size		Max Pressure Drop - psid (Bard)							
		Basic Trim Material							
in	(DN)	"P" – 17-4PH SST		"S" – 316L SST		"M" – Monel		"T" – Hybrid *	
1/2" – 2"	(15-50)	3000	(206.9)	800	(55.1)	1500	(103.4)	3000	(206.9)
2-1/2" – 4"	(65-100)	3000	(206.9)	800	(55.1)	1500	(103.4)	3000	(206.9)

\* 17-4PH SST plug & piston, Monel cage.

**TABLE DAG-5  
TEMPERATURE LIMITS  
FOR ELASTOMERIC MATERIALS**

Elastomer			T Maximum		T Minimum	
Seats	ID	Description	°F	(°C)	°F	(°C)
		PolyAll	Proprietary Polyurethane Derivative	225°	(107°)	-60°
	GF-TFE	Glass-filled Polytetrafluorethylene	425°	(218°)	-325°	(-198°)
	V-TFE	Virgin TFE	400°	(205°)	-325°	(-198°)
	CTFE	Chlorotrifluoroethylene TFE	300°	(148°)	-325°	(-198°)
	BC	Neoprene	225°	(107°)	-35°	(-37°)
	NBR	Buna-N	320°	(160°)	-40°	(-40°)
	FKM	Fluorocarbon Elastomer	400°	(205°)	0°	(-17°)
Diaphragms	3-Ply	3-Ply TFE/FKM/TFE	400°	(205°)	0°	(-17°)
	BC	Neoprene (Polychloroprene)	250°	(121°)	-65°	(-53°)
	EPR	Ethylene Propylene	300°	(148°)	-40°	(-40°)
	FK	Fluorosilicone	350°	(177°)	-65°	(-54°)
	FKM	Fluorocarbon Elastomer	400°	(205°)	0°	(-17°)
	NBR	Buna-N (Nitrile)	250°	(121°)	-70°	(-56°)
	FKM+TFE	Fluorocarbon Elastomer + TFE	400°	(205°)	0°	(-17°)
Static Seals	RTFE	Bronze-filled TFE	425°	(218°)	70°	(21°)
	V-TFE	Virgin TFE	400°	(205°)	-325°	(-198°)
	EPR	Ethylene Propylene	300°	(148°)	-40°	(-40°)
	FK	Fluorosilicone	350°	(177°)	-65°	(-54°)
	FKM	Fluorocarbon Elastomer	400°	(205°)	-20°	(-28°)
	NBR	Buna-N	212°	(100°)	-40°	(-40°)
	SST/TFE	301/302 SST U-cup / TFE	400°	(205°)	-325°	(-198°)
	HC/TFE	Hastelloy C U-cup / TFE	400°	(205°)	-325°	(-198°)
Dynamic Seals	"PR"	Piston Ring Assy, GF-TFE / SST	425°	(218°)	-40°	(-40°)
	"PW"	PRA* w/Wiper, GF-TFE / SST / GF-TFE	425°	(218°)	70°	(21°)
	"CW" – EPR/TFE	TFE Cap Seal, EPR O-ring, GF-TFE Wiper	300°	(148°)	-40°	(-40°)
	"CW" – NBR/TFE	TFE Cap Seal, NBR O-ring, GF-TFE Wiper	212°	(100°)	-40°	(-40°)
	"CW" – FK/TFE	TFE Cap Seal, FK O-ring, GF-TFE Wiper	350°	(177°)	-40°	(-40°)
	"CW" – FKM/TFE	TFE Cap Seal, FKM O-ring, GF-TFE Wiper	400°	(205°)	-20°	(-28°)
	"CP" – EPR/TFE	TFE Cap Seal, EPR O-ring	300°	(148°)	-40°	(-40°)
	"CP" – NBR/TFE	TFE Cap Seal, NBR O-ring	212°	(100°)	-40°	(-40°)
	"CP" – FK/TFE	TFE Cap Seal, FK O-ring	350°	(177°)	-10°	(-23°)
	"CP" – FKM/TFE	TFE Cap Seal, FKM O-ring	400°	(205°)	-20°	(-28°)
	SST/TFE	301/302 SST U-cup / TFE	400°	(205°)	-325°	(-198°)
	HC/TFE	Hastelloy C U-cup / TFE	400°	(205°)	-325°	(-198°)
	ELG/TFE	Elgiloy / TFE U-cup	400°	(205°)	-325°	(-198°)

\* PRA - Piston Ring Assembly

Metal Diaphragm		T Maximum		T Minimum	
ID	Description	°F	(°C)	°F	(°C)
BE-CU	Beryllium Copper	400°	(205°)	-325°	(-198°)

**ABBREVIATIONS**

FK = Fluorosilicone	NBR = Buna-N	PTFE = Polytetrafluoroethylene	PRA = GF-TFE/SST
FKM = Fluorocarbon Elastomer	RTFE = Brz-fill TFE	V-TFE = Virgin TFE	BC = Neoprene
EPR = Ethylene Propylene	GF-TFE = Glass-fill TFE	CTFE = Chlorotrifluoroethylene TFE	ELG = Elgiloy



**TABLE DAG-6  
REDUCER MAXIMUM CAPACITY WITH PLUG WIDE-OPEN**

Body Size		Full Port Max Capacity		Full Port Max Capacity	
in	(DN)	Cv	Kv	Cv	Kv
1/2"	(15)	4.0	3.4	3.5	3.0
3/4"	(20)	8.0	6.9	3.5	3.0
1"	(25)	15	13	3.5	3.0
1-1/4"	(32)	23	20	6.0	5.2
1-1/2"	(40)	30	26	6.0	5.2
2"	(50)	60	52	12	10.4
2-1/2"	(65)	90	78	X	
3"	(80)	120	104		
4"	(100)	220	190		
<b>Diaphragm</b>		<b>Composition</b>		<b>Metal</b>	
<b>NOTE:</b> The above Cv factors may be used for sizing of safety relief valves or rupture discs.					

**TABLE DAG-9  
REDUCER – LOWER PISTON SPRING RANGES**

Basic Unit		Lower Piston Spring Range psig	Application Notes
Model	Diaphragm		
DA1	Comp	1-2	1-5 and 1-10 range spring only
DA1	Metal	4-10	–

- NOTES:**
1. All metallic diaphragm constructions MUST include a lower piston spring.
  2. The 1–2 psig lower piston spring should only be used with low pressure setpoints. (Psp ≤ 10 psig) and with composition diaphragms.
  3. Lower spring material matches main metallic trim in corrosion resistance.

**TABLE DAG-10  
INBOARD LEAKAGE RATINGS \*  
Per ANSI/FCI 70-2**

Seat Material	Dynamic Seal	
	O-Ring	Dynamic Seals Except O-Ring
CTFE, GF-TFE, and V-TFE	IV	IV
BC, NBR, PolyAll, FKM	VI	IV
*Inboard leak rates are the composite leakage of the seat leakage + dynamic seal leakage, considered as a single inboard leakage value.		

**TABLE DAG-11  
REDUCER RECOMMENDED VELOCITY LIMITS**

Application Fluid	Valve		Valve Body Outlet		Downstream Pipe		Units
	Type	Size Range	Recommend	Max.	Recommend	Max.	
Liquid	PRV	1/2"-4"	15	20	5-8	16	Ft/Sec
		6"	15	25	7-12	20	
		8"-12"	-	-	9-14	24	
Gas	PRV	1/2"-1"	0.20	0.40	0.15	0.30	Mach #
		1-1/4"-2"	0.25	0.45	0.20	0.30	
		2-1/2"-6"	0.30	0.50	0.25	0.35	
		8"-12"	-	-	0.25	0.40	
Steam	PRV	1/2"-1"	0.20	0.30	0.10	0.30	Mach #
		1-1/4"-2"	0.22	0.32	0.12		
		2-1/2"-6"	0.25	0.35	0.20		
		8"-12"	-	-	0.22		
<b>NOTES:</b> <ol style="list-style-type: none"> <li>Liquids experiencing no 2-phase flow at valve outlet will have same valve body outlet velocity as inlet velocity.</li> <li>Liquids experiencing 2-phase flow at valve outlet should have average velocity less than 150-200 ft/sec.</li> <li>Liquids experiencing 2-phase flow at outlet pipe should have average velocity less than 20-50 ft/sec.</li> <li>If valve outlet exceeds recommended limits, then can use external sensing to reach maximum limits.</li> <li>On gas service, a pilot operated prv can work with a outlet Mach = 0.75.</li> </ol>							

**TABLE DAG 13  
MAXIMUM RECOMMENDED NOISE LIMITS \***

Criteria	Body Sizes		Noise Level - dBA
	in	(DN)	
Per OSHA Regs. w/noise attenuation methods incorporated.	All	All	85-95
Sch. 80 pipe, no insulation.	1/2"-2"	(15-50)	95
Std. wt. pipe, no insulation.	2-1/2"-4"	(65-100)	98
* Consult Factory for ALL applications exceeding 97 dBA noise prediction.			

**Schemes To Reduce High Noise –**

- Staging – using two separate throttling valves in series.
- dB Plates – using 1, 2 or 3-stage dB Plate cartridges downstream of a throttling valve.
- Paralleling – using two separate throttling valves in parallel.
- Combinations – using multiple methods of above three possibilities.

**TABLE DAG-14**  
**RECOMMENDED INTERNAL MATERIALS**  
**For P<sub>max</sub> Reference Individual Technical Bulletins**

	LIQUIDS			
	Fluid	Tmax °F	Tmin °F	Metal Trim
LIQUIDS	<b>Industrial Water</b> – Cold	180°	32°	P1
	Hot	225°	32°	P4
	DI, DM	225°	32°	PJ
		250°	32°	PL
	Seawater	180°	-20°	MQ, MW
	<b>Fuel Oils</b> – Diesel, #1, #2‡	180°	-30°	P5
	Bunker C, #3 - #6‡	180°	-30°	P5
		400°	0°	PC
	Jet Fuel JP3, JP4, JP5, JP6‡	400°	0°	PC
	Kerosene‡	400°	0°	PC
	<b>Crude Oils</b> – Sweet‡	225°	0°	PA
		400°	0°	PC
	Sour‡	225°	0°	NS
	<b>Heat Transfer Oils</b> – Dowtherm, Therminol, Mobil-Therm, Silvatherm	400°	0°	PC
	<b>Misc. Oils</b> – Lube Oil‡	180°	-30°	P5
Naptha‡	400°	0°	PC	
Turbine Oil‡	225°	0°	PA	
<b>Edible Oils</b> – Vegetable Oil‡	180°	-30°	PH	
Animal Fats‡	180°	-30°	PH	
Seed Oils‡	180°	-30°	PH	
LIQUIDS	<b>Inorganic Acids</b> – Acetic - 5%	100°	0°	SL
	Acetic - 30%	100°	0°	SL
	Sulfuric - conc.	100°	0°	CF *
	Sulfuric - dilute	100°	0°	CF *
	Nitric - conc.	140°	0°	SL
	Nitric - dilute	140°	0°	SL
	Hydrofluoric (air free) - dilute, concentrate	100°	0°	CF *
	Hydrobromic	140°	0°	CF *
	Phosphoric - dilute, concentrate	150°	0°	SL
	<b>Misc. Liquids</b> – Gasoline‡	150°	-30°	P5
	Benzene (C <sub>6</sub> H <sub>6</sub> )‡	150°	0°	SL
	Chlorine (Cl <sub>2</sub> )	150°	0°	ML
	Bromine (Br <sub>2</sub> )	150°	0°	CF *
	Ammonia (NH <sub>3</sub> )	140°	0°	SL
	Hydrogen Peroxide (H <sub>2</sub> O <sub>2</sub> )	125°	0°	SL
Hydrogen Chloride (HCl)	125°	0°	ML	
Hydrogen Bromide (HBr)	125°	0°	SL	
Cane Sugar Liquor	180°	0°	PH	

‡ In accordance with ASME B31.3 "Process Piping", do not use Ductile Iron Body for hydrocarbon or flammable service with inlet pressures greater than 150 psig (10.3 Barg) or temperatures greater than 300 deg F (149 deg C).  
 \* CF = Consult Factory

	GASES			
	Fluid	Tmax °F	Tmin °F	Trim
Atmospheric Gases	<b>Atmospheric Gases</b> – O <sub>2</sub> (GOX)	225°	-60°	M7
		350°	-65°	M9
		350°	-325°	TN
	N <sub>2</sub> (GN <sub>2</sub> ), Air, Argon	180°	-60°	P2
		350°	-65°	P8
	CO <sub>2</sub> (dry)	180°	-40°	P6
CO <sub>2</sub> (wet)	180°	-40°	P5	
Process Gases	<b>Process Gases</b> – Nat. Gas (Sweet)	180°	-65°	P9
	Nat. Gas (Sour)	180°	-40°	NR
	LPG (propane)	180°	-40°	PH
	Ammonia	120°	-40°	CF *
	Hydrogen	180°	-325°	SN
	Helium	180°	-325°	SN
	Chlorine (dry)	300°	0°	ME
	Hydrogen Chloride (dry)	120°	-40°	SJ
	Hydrogen Bromide (dry)	120°	0°	PE
	Hydrogen Fluoride (dry)	120°	0°	PE
	Hydrogen Sulfide (dry)	140°	0°	NS
	Hydrogen Sulfide (wet)	140°	0°	NS
	Sulfur Dioxide (dry)	120°	0°	PE
STEAM	P1 ≤ 125 psig	350°	—	PG

## DAG-14 SUPPLEMENT CHEMICAL RESISTANCE

**General Statement:** Statements located within this technical bulletin concerning suitability of fluids with TFE materials are general statements, and should not be construed as recommendations. Any statements of suitability are the result of a compilation of various sources of information based on experience, tests, and published technical literature. No guarantee or warranty is in anyway implied for a given particular service or application.

**Additional Reference:** For an inclusive listing covering a broader range of service application fluids, reference "Handbook of Corrosion Resistant Piping", P.A. Schweitzer, Industrial Press or "Compass Corrosion Guide", 2nd Edition, K.M. Pruett, Compass Publications. This publication will include information based on the following fluid variables:

1. Solution concentration
2. Pressure
3. Temperature

### DAG-15

#### Inverse Sympathetic Ratio (ISR) - effect on regulator performance.

DA1 regulators utilize a top and bottom guide, "flow to open" trim design. The top guide also acts as a "balancing" piston to oppose the forces generated by the inlet pressure acting on the valve plug. A small residual imbalance between the piston and the valve plug helps to reduce seat leakage at high differential pressures across the seat joint. This same imbalance produces an Inverse Sympathetic Ratio, ISR effect, as the delta pressure across the seat (DP) changes. The magnitude of the ISR effect is given in Table DAG-15 for both the pressure reducing and back pressure designs.

TABLE DAG-15		
Body Size		PRV - DA1/DA2/DA4/DAP
in	(DN)	
1/2", 3/4", 1"	(15,20,25)	0.03
1-1/4", 1-1/2"	(32,40)	0.04
2"	(50)	0.02
2-1/2", 3", 4"	(65,80, 100)	0.054

A typical example of the ISR effect is the rise in outlet setpoint as the inlet pressure decays from a pressure vessel or compressed gas bottle. A 1" DA1 connected to a nitrogen bottle at 3000 psig can be adjusted to deliver downstream pressure, P2, of 100 psig. The P2 will rise to 181.48 psig as the compressed gas bottle pressure decays to 284 psig, because of the ISR effect. The calculation follows below:

$$P_{sp} = P_2 + (ISR \times \Delta P_1)$$

$$\Delta P_1 = \text{INITIAL INLET} - \text{FINAL INLET}. (3000 - 284) = 2716$$

$$P_2 = 100$$

$$ISR = 0.03 \text{ (1.0" DA1)}$$

$$P_{sp} = 100 + (0.03 \times 2716)$$

$$P_{sp} = 181.48$$

**NOTE:** For a rising DP across the seat, the ISR effect would cause a downward shift or offset in the setpoint.

If the ISR effect is unacceptable, then two regulators installed in series will greatly reduce the overall ISR effect. Overall ISR effect = ISR (first stage regulator) x ISR (second stage regulator). For example, in the same application of a N2 bottle source using two 1" DA1 regulators, the setpoint offset - 0.03 x 0.03 x 2716 = 2.44. In summary, the outlet pressure will rise from 100 psig to 102.44 psig as the inlet pressure decays from 3000 psig to 200 psig.

In a similar manner the ISR effect will produce an offset between the loading pressure, PL, and the pressure setpoint of a dome loaded regulator. For example, a 4" DA4 with an inlet pressure, P1 of 300 psig and an outlet pressure, P2 of 50 psig would require a loading pressure, PL = (P1 - P2) x ISR + P2 = (300-50) x 0.054 + 50 = 63.5 psig. In addition, if the DP changes, then a setpoint offset would be observed with a constant loading pressure.

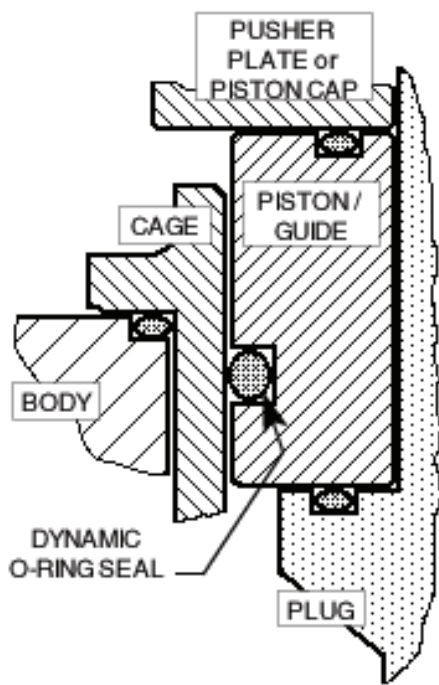

O-RING DYNAMIC SEAL

PRV, BPV

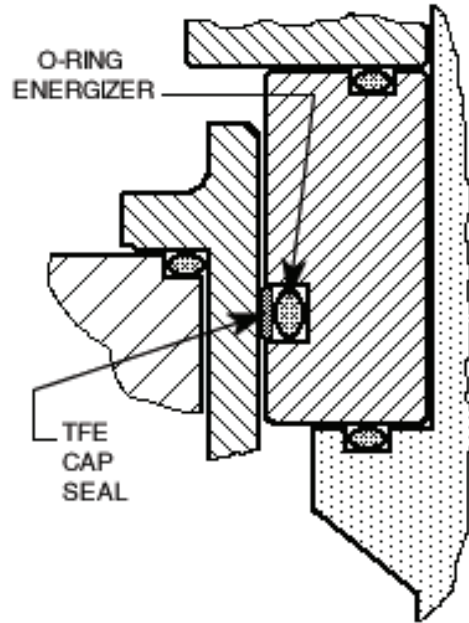

TFE CAP DYNAMIC SEAL

BPV

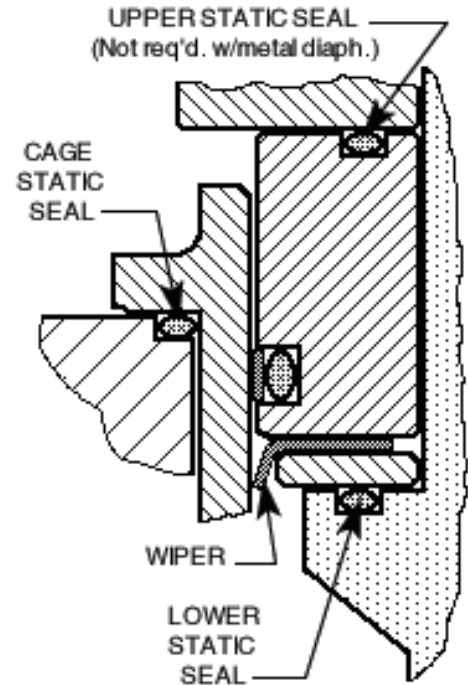

TFE CAP DYNAMIC SEAL + WIPER

PRV

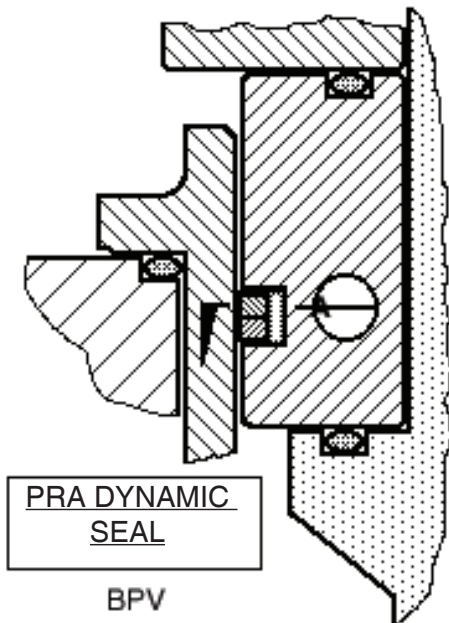

PRA DYNAMIC SEAL

BPV

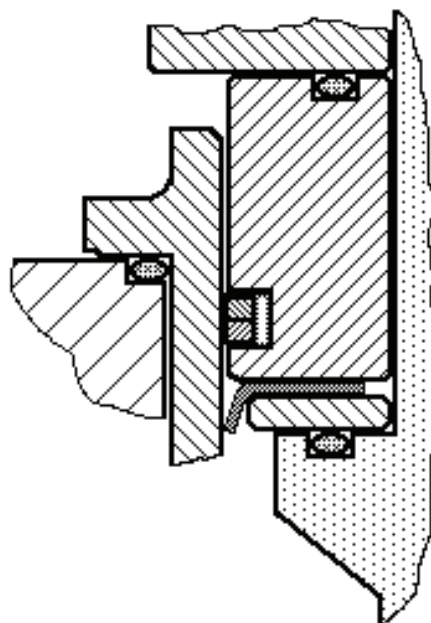

PRA DYNAMIC SEAL + WIPER

PRV

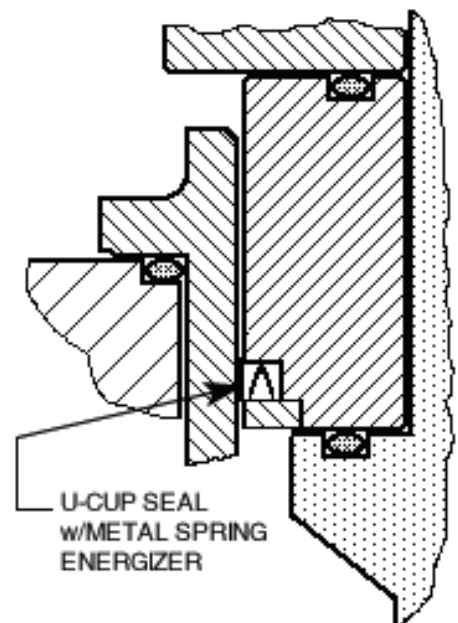

U-CUP DYNAMIC SEAL

PRV, BPV

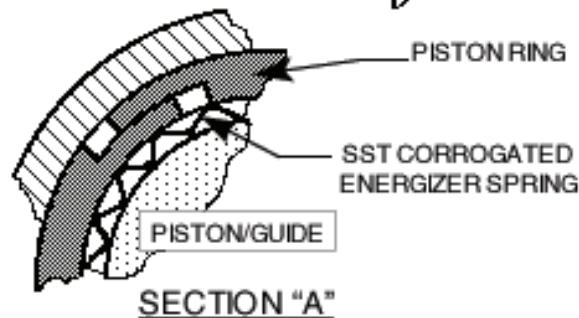

SECTION "A"

FIGURE DAG-F1  
DYNAMIC & STATIC SEALS

**FIGURE DAG-F2**  
**Location of BODY / SPRING CHAMBER TAPS**

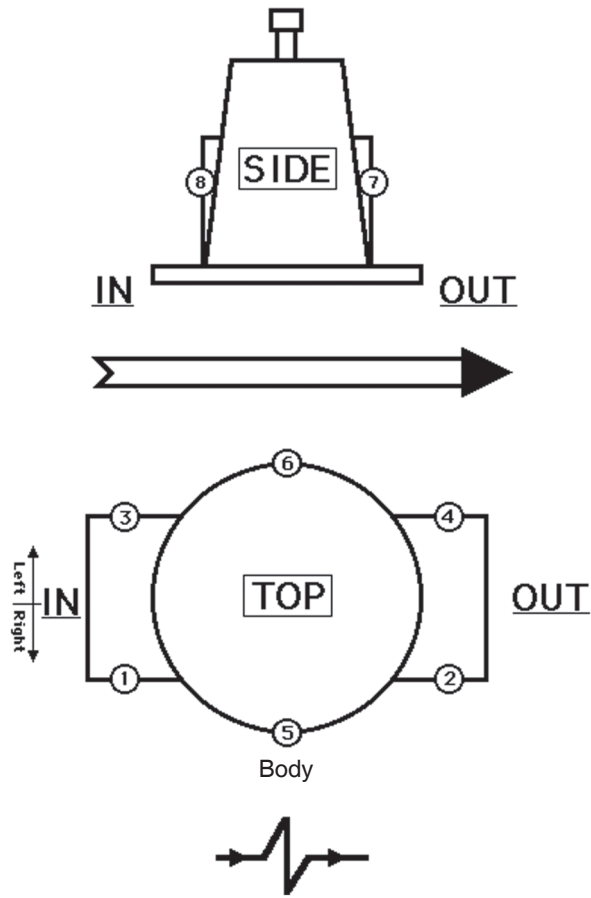

**Flow To Open Direction**

Location	Description	Opt. No.	NPT - Size	Body Mat'l.
1 & 2	Inlet & Outlet – Right	STD	1/4"	DI, CS & SST
1, 2 & 3	Inlet & Outlet – Right	STD	1/4"	BRZ
5	External Sensing – Right	STD	1/4"	DI, BRZ, CS & SST
1, 2, 3 & 4	Inlet & Outlet – Right Inlet & Outlet – Left	85	1/4"	DI, BRZ, CS & SST
5 & 6	Double External Sensing	85	1/4"	DI, BRZ, CS & SST

Location	Description	Opt. No.	NPT - Size	Sp. Ch. Mat'l.
7	Spring Ch. – Outlet Side	25	1/4"	DI, BRZ, CS & SST

## DIMENSION and WEIGHTS

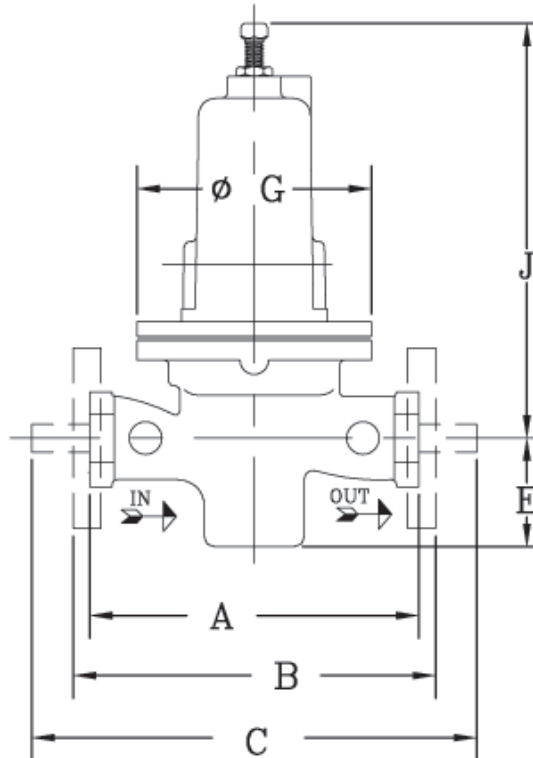

**ENGLISH UNITS (in) (lbs)**

**METRIC UNITS (mm) (kg)**

Dimen.	End Conn.	Body Mat'l.	Body Size					
			1/2", 3/4" & 1"	1-1/4" & 1-1/2"	2"	2-1/2"	3"	4"
<b>A</b>	NPT	DI, BRZ	6.00	9.88	9.88	X		
		CS, SST, HC	8.25	9.88	9.75			
<b>B</b>	125# FF	DI	X			10.88	11.75	13.88
	250# RF	DI				11.50	12.50	14.50
	150# FF	BRZ **	9.63	11.50 √	11.50	10.88	11.75	13.88
	300# FF	BRZ **	9.63	11.50 √	11.50	11.50	12.15	14.50
	150# RF	CS, SST	10.75	12.38 √	10.00	10.88	11.75	13.88
		HC *			13.75	—	—	—
	150# RF ‡	CS, SST	14.00	14.00 √	14.00	—	—	—
	300# RF	CS, SST	10.75	12.38 √	10.50	11.50	12.50	14.50
		HC *			14.25	—	—	—
	300# RF ‡	CS, SST	14.00	14.00 √	14.00	—	—	—
600# RF	CS, SST	10.75	12.38 √	11.25	12.25	13.25	15.50	
600# RF ‡	CS, SST	14.00	14.00	14.00	—	—	—	
<b>C</b>	Opt-32 EXT NIPS	CS, SST	14.00	15.75	15.75	X		
	OPT-41	SST	11.00	15.25	15.50			
<b>E</b>	All	All	2.84	3.69	4.00	5.25	5.75	7.00
<b>G</b>	All	All	6.00	7.00	8.00	10.00	11.00	11.13
<b>J</b>	All	All	12.38	14.25	16.00	26.50	27.25	27.75
<b>J w/ Opt-80</b>	All	All	17.00	17.50	19.00	—	—	—
<b>WEIGHT</b>	w/ Flanges	All	28	43	52	—	—	—
	w/Flanges	All	35	55	68	100	175	190

End Conn.	Body Size					
	DN15, DN20 & DN25	DN32 & DN40	DN50	DN65	DN80	DN100
NPT	152	251	251	X		
	209	251	248			
125# FF	X			276	298	352
250# RF				292	318	368
150# FF	246	292 √	292	276	298	352
300# FF	246	292 √	292	292	309	368
150# RF	273	314 √	254	276	298	352
			349	—	—	—
150# RF ‡	356	356 √	356	—	—	—
300# RF	273	314 √	267	292	318	368
			362	—	—	—
300# RF ‡	356	356 √	356	—	—	—
600# RF	273	314 √	286	311	336	394
600# RF ‡	356	356	356	—	—	—
Opt-32 EXT NIPS	356	400	400	X		
OPT-41	279	387	394			
All	72	94	102	133	146	178
All	152	178	203	254	279	283
All	314	362	406	673	692	705
All	432	444	483	—	—	—
w/ Flanges	13	20	24	—	—	—
w/Flanges	16	25	31	45	79	86

\* HC body material available in sizes 1", 1-1/2", & 2" ONLY.  
 \*\* Flanged BRZ bodies available in sizes 1", 1-1/2", 2", 2-1/2", 3", & 4" ONLY.  
 √ Flange Connections not available for 1-1/4" size.  
 ‡ Opt-34: Special 14" F to F Flange dimensions, CS and SST body material only.  
 Consult Factory for dimensions of ISO DIN Flanged units. (PN16, PN25, PN40)

The contents of this publication are presented for informational purposes only, and while every effort has been made to ensure their accuracy, they are not to be construed as warranties or guarantees, express or implied, regarding the products or services described herein or their use or applicability. We reserve the right to modify or improve the designs or specifications of such product at any time without notice. Cashco, Inc. does not assume responsibility for the selection, use or maintenance of any product. Responsibility for proper selection, use and maintenance of any Cashco, Inc. product remains solely with the purchaser.





Cashco, Inc.  
P.O. Box 6  
Ellsworth, KS 67439-0006  
PH (785) 472-4461  
Fax. # (785) 472-3539  
www.cashco.com  
email: sales@cashco.com  
Printed in U.S.A. DA1-TB

Cashco GmbH  
Handwerkerstrasse 15  
15366 Hoppegarten, Germany  
PH +49 3342 30968 0  
Fax. No. +49 3342 30968 29  
www.cashco.com  
email: germany@cashco.com

Cashco do Brasil, Ltda.  
Al.Venus, 340  
Indaiatuba - Sao Paulo, Brazil  
PH +55 11 99677 7177  
Fax. No.  
www.cashco.com  
email: brazil@cashco.com