

MODEL 3600

SIDE-MOUNTED VACUUM RELIEF VENT

OVERVIEW

The Model 3600 vacuum relief vent is intended for use on storage tanks, vapor recovery systems and process systems where vacuum relief is required.

SPECIAL FEATURES

Modular Design:

The Model 3600 end-of-line conservation breather vent is part of Valve Concepts, Inc. modular vent product line. The Model 3600 can easily be field converted to a pressure only vent, a pressure/vacuum vent with pipe away and can either be direct acting or pilot operated. Only Valve Concepts offers complete modularity throughout its complete vent product line.

Maintains Accurate Settings:

Minimum setting available is approximately 0.25 oz/in² and maximum setting upwards to 2.5 psig. See Set Point Limits Tables 4(a) and 4(b). If higher settings are required, see Valve Concepts Series 4000 Spring Loaded Vents. All vents are tested to Valve Concepts, Inc. high standards for both seat leakage and set point prior to shipment. A certified test certificate is included with each vent verifying the accuracy of vacuum setting and seat leakage. Seat leakage rates meet or exceed current editions of API Standard 2000.

Condensate Drainage:

Self-draining body and specially designed seat ring keeps condensate away from seating surfaces, preventing freezing, binding, and clogging.

Air-Cushioned Seating:

Air-cushion seating provides tight sealing to reduce evaporation losses and the release of toxic vapors. The pallets have outer guiding and center stabilizing stem to provide self alignment and tight seating.

Sizes-Connections:

Available in line sizes 2" (DN50) through 12" (DN300). Carbon steel and stainless steel vents have raised face tank connection flange. All other vent materials come standard with flat face flanges. Standard flanged bolt patterns are available to mate with ASME 150, PN16, or PN10 flanged connections.

*Derakane 470 and Hetrion 800 are registered trademarks of Ashland, inc.

TECHNIQUE

Weight loaded pallets in the vent housing allow the intake of air and the escape of vapors as the tank breathes due to thermal changes and product movement out of the tank. The pallet opens and closes to permit in breathing necessary to maintain tank pressure and prevent tank damage due to excessive vacuum.



MODEL 3600



LINE SIZES AVAILABLE

2" (DN50), 3" (DN80), 4" (DN100),
6" (DN150), 8" (DN200), 10" (DN250),
12" (DN300)



END CONNECTIONS FLANGED



COMMON APPLICATIONS

STORAGE TANKS, VAPOR RECOVERY
SYSTEMS, PROCESS SYSTEMS WHERE
VACUUM RELIEF IS REQUIRED



DESIGN PRESSURE MULTIPLE SET VACUUM RANGES AVAILABLE

CONSTRUCTION

Housing Material: Available in aluminum, carbon steel, 316 stainless steel, 304 stainless steel or corrosion resistance fiberglass reinforced plastic (FRP) with Derakane 470* or Hetron 800* resins.

Seat Rings: Replaceable metal seat rings available in aluminum, 304 stainless steel, or 316 stainless steel. FRP vents have integral seats that match the body resin material.

Pallets Assemblies: Replaceable 316 stainless steel pallet assemblies are standard for metal vents. Pallet assemblies lower than 0.5 oz/in² may contain a polycarbonate pallet material. Replaceable FRP pallet assemblies match the body resin material.

Pallet Diaphragms: Standard seal material is FEP. Also available in FKM, EPDM, and BUNA-N.

STANDARD/GENERAL SPECIFICATIONS

Gaskets: Expanded PTFE for FEP seal materials. Gasket materials match the seal materials for BUNA-N, EPDM, and FKM.

Vacuum Protection Screen: Replaceable 4x4 welded mesh screen in 304 stainless steel to prevent obstructions to vacuum relief flow path. FRP vents use polyethylene mesh material.

Set Point Accuracy: Vacuum setpoints are calibrated to be within +/-2% of customer requested setting across the range of available settings. Exceeds API Bulletin 2521.

Seat Leakage: Meets or exceeds current edition of API Standard 2000.

Calibration Certificate: Calibration certificates are issued standard with every line item demonstrating acceptable set point accuracy and seat leakage rates.

Painting: All carbon steel surfaces are epoxy coated VCI blue per Cashco specification S-1777. Flange mating surfaces, threaded holes, and corrosion resistant parts are excluded. Non-coated surfaces have lubricant applied for corrosion prevention.

OPTION SPECIFICATIONS

Vacuum Flame Screen: Replaceable 30x30 mesh screen in 304 stainless steel. Used to help prevent ignition of internal vapors through the vacuum relief port. This option replaces the standard vacuum protection screen.

Sizing Report: Formal report documenting tank inbreathing requirements and vent performance per customer application. Displacement flow requirements and vent performance are in accordance with the current edition of API Standard 2000.

NACE MR0175: Internal wetted portions meet NACE standard MR0175 when exterior of the vent is not directly exposed to a sour gas environment, buried, insulated, or otherwise denied direct atmospheric exposure. For use with carbon steel or 316 stainless steel body materials only.

Oxygen Cleaning: All components oxygen cleaned, bagged, and tagged in accordance to Cashco specification S-1134. Must select either 304 or 316 stainless steel body materials and stainless steel loading weights.

ATEX 2014/34/EU: Declaration of Conformity available for Group IIB gasses. See Model 3600 IOM for more details.

PED 2014/68/EU: Sound Engineering Practice (SEP) certificate available for pressures up to 0.5 barg.

50 PSIG Back Pressure: Special design configuration where higher tank pressures above 2 psig (0.13 Barg) may cause damage to normal trim. Includes heavy duty pressure and vacuum covers, pallet, and special seat ring for use with o-ring seals in place of diaphragms. Pnuematically tested per Cashco specification S-1812 in addition to normal function testing and calibration. See TABLES 4(c) and 4(d) for min/max range of vacuum set points. Not available with aluminum or FRP body construction.

Vacuum Relief Capacity Standard Screen

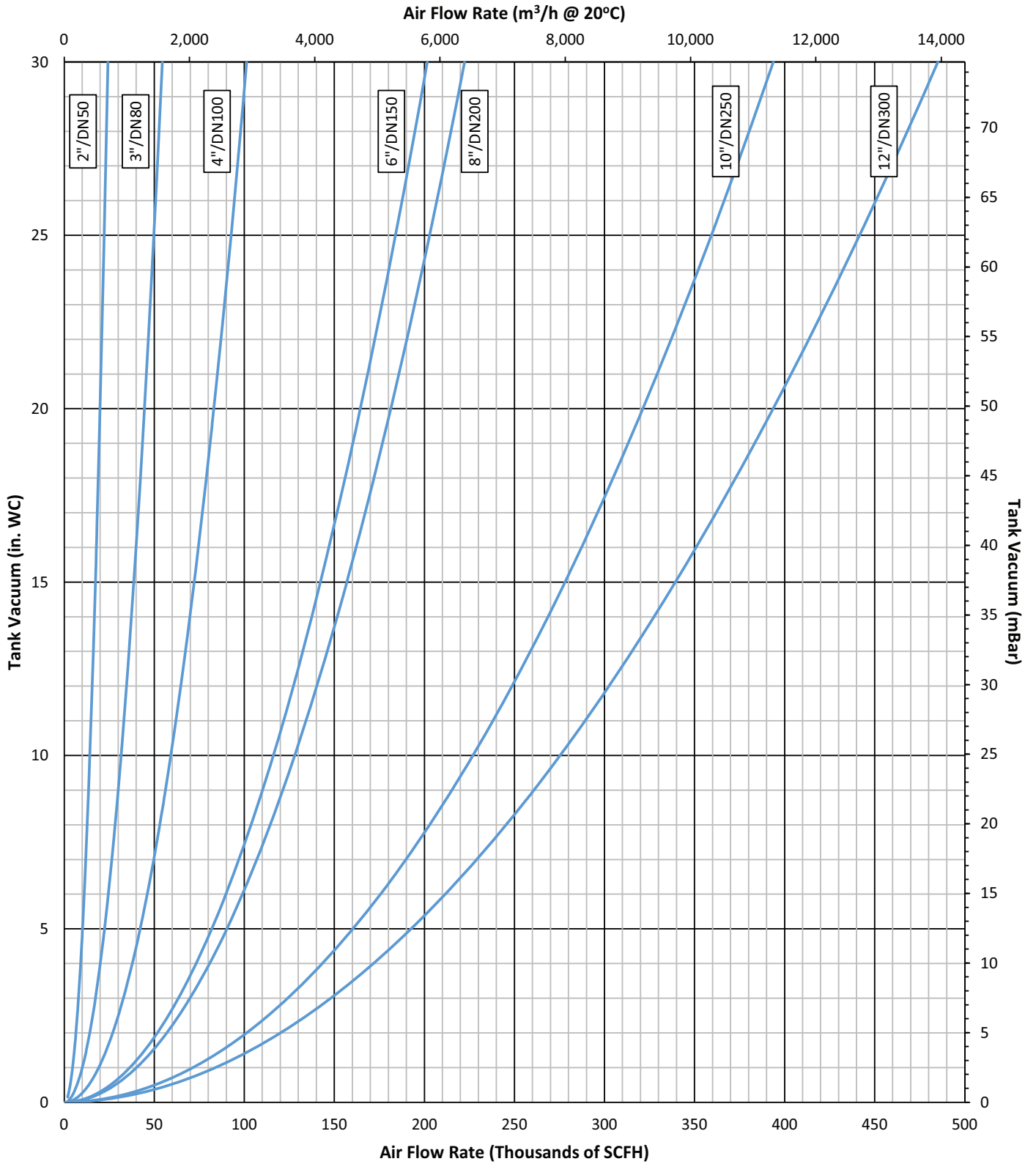

Vacuum Relief Capacity Flame Screen

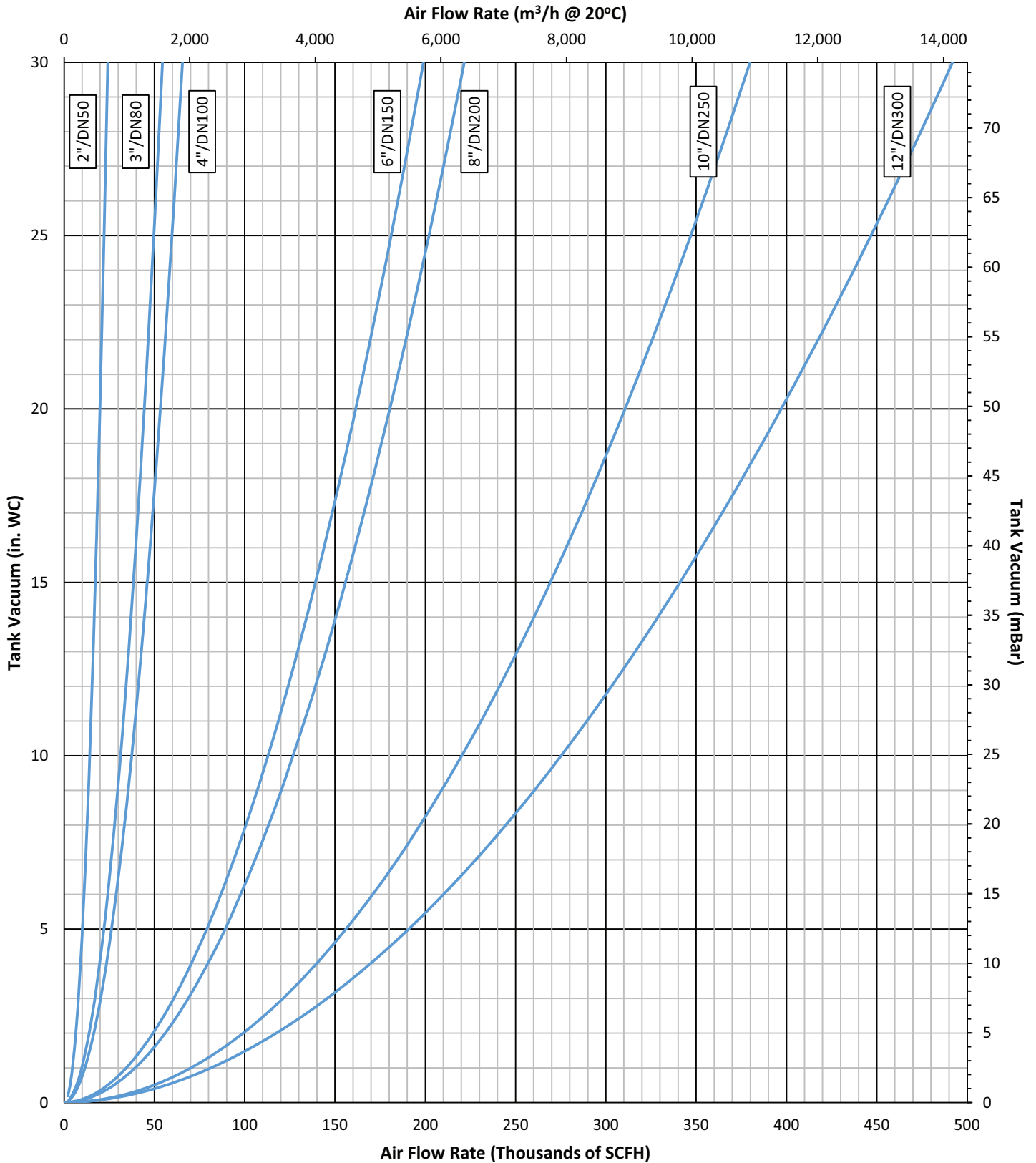

TABLE 1 - MATERIALS OF CONSTRUCTION

COMPONENT MATERIALS	BODY MATERIALS					
	ALUM	CS	316 SST	304 SST	DERAKANE 470	HETRON 800
BODY COVERS	ALUM	CS	316 SST	304 SST	DERAKANE 470	HETRON 800
SEAT RINGS	ALUM, 316 SST	316 SST	316 SST	304 SST	DERAKANE 470	HETRON 800
PALLET ASSEMBLIES	PC ¹ , 316 SST	PC ¹ , 316 SST	PC ¹ , 316 SST	PC ¹ , 316 SST	DERAKANE 470	HETRON 800
VACUUM PALLET GUIDES	316 SST	316 SST	316 SST	316 SST	DERAKANE 470	HETRON 800
FLANGE STUDS	304 SST	304 SST	304 SST	304 SST	N/A	N/A
FASTENERS	316 SST	316 SST	316 SST	316 SST	316 SST, ALLOY C276	316 SST, ALLOY C276
PALLET WEIGHTS	CS ² , SST	CS ² , SST	CS ² , SST	CS ² , SST	DERAKANE 470 ³	HETRON 800 ³
SCREENS	304 SST	304 SST	304 SST	304 SST	POLYETHYLENE	POLYETHYLENE

1 - Polycarbonate pallet material may be used for settings less than 0.5 oz/in². All other parts are 316 SST.
 2 - Carbon steel pallet weights are epoxy coated per Cashco specification S-1777.
 3 - FRP encapsulated carbon steel utilizes same resin as body.

TABLE 2 - PRESSURE/TEMPERATURE RATINGS

BODY MATERIAL	MAWP		Temperature	
	PSI	(BAR)	°F	(°C)
Aluminum	15	(1)	-325/+250	(-198/+121)
Carbon Steel ²	15/50	(1/3.4)	-20/+400	(-28/+204)
316 Stainless Steel ²	15/50	(1/3.4)	-325/+400	(-198/+204)
304 Stainless Steel ²	15/50	(1/3.4)	-325/+400	(-198/+204)
Derakane 470 ¹	2	(0.14)	N/A	
Hetron 800 ¹	2	(0.14)	N/A	

¹ Temperature limits vary based on resin material, media, concentration, and storage temperature. Consult factory for more information.
² MAWP determined by standard or 50 PSIG Back Pressure configurations.

TABLE 3(a) - DIAPHRAGM TEMPERATURE LIMITS

Material	°F	(°C)
FEP	-400/+400	(-240/+204)
BUNA-N	-40/+250	(-40/+121)
EPDM	-40/+225	(-40/+107)
FKM	-20/+400	(-28/+204)

TABLE 3(b) - O-RING TEMPERATURE LIMITS (50 PSI BACK PRESSURE OPTION)

Material	°F	(°C)
FEP ENCAPSULATED FKM	-15/+400	(-26/+204)
BUNA-N	-20/+250	(-28/+121)
EPDM	-70/+250	(-56/+121)
FKM	0/+400	(-17/+204)

TABLE 4(a) - SET POINT LIMITS

Metallic Vents (OZ/IN ²)			FRP Vents (OZ/IN ²)		
Size	Vacuum		Size	Vacuum	
	MIN	MAX		MIN	MAX
2"	0.30	34.10	2"	0.50	32.00
3"	0.27	36.90	3"	0.50	32.00
4"	0.19	43.10	4"	0.50	32.00
6"	0.19	39.80	6"	0.50	32.00
8"	0.19	39.70	8"	0.50	32.00
10"	0.20	42.10	10"	0.50	32.00
12"	0.20	35.70	12"	0.50	32.00

TABLE 4(c) - SET POINT LIMITS (oz/in²) 50 PSIG BACK PRESSURE OPTION

Size (NPS)	MIN	MAX ²
2	1.7	34.5
3	1.6	36.6
4	2.1	38.2
6	2.0	32.9
8	1.9	39.2
10	2.6	32.5
12	3.9	36.3

TABLE 4(d) - SET POINT LIMITS (mBar) 3.4 BARG BACK PRESSURE OPTION

Size (DN)	MIN	MAX ²
50	7.3	149
80	6.9	158
100	9.0	165
150	8.6	142
200	8.2	169
250	11.2	140
300	16.8	156

NOTES:

- 1) MIN set points may utilize polycarbonate pallet material at factory discretion.
- 2) MAX set points may utilize extended covers at factory discretion.

DIMENSIONS
Aluminum, Carbon Steel & Stainless Steel Body

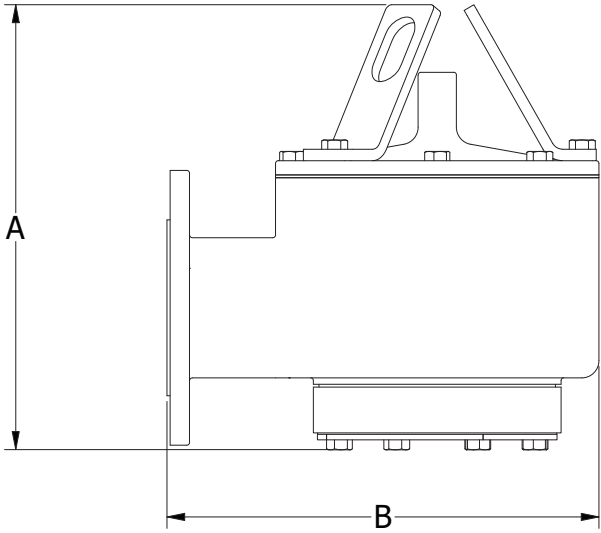

STANDARD CONFIGURATION - FRONT VIEW

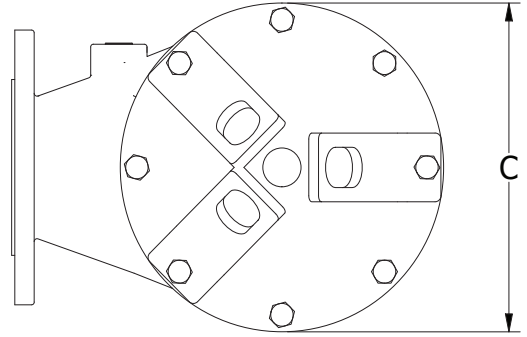

STANDARD CONFIGURATION - TOP VIEW

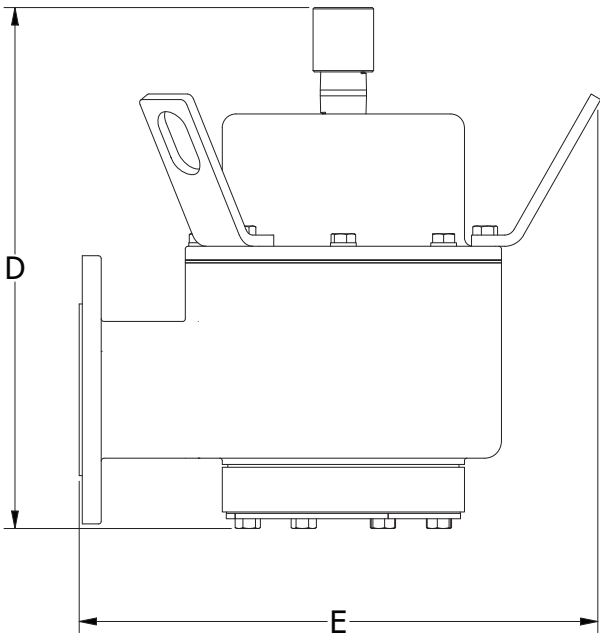

EXTENDED CONFIGURATION - FRONT VIEW

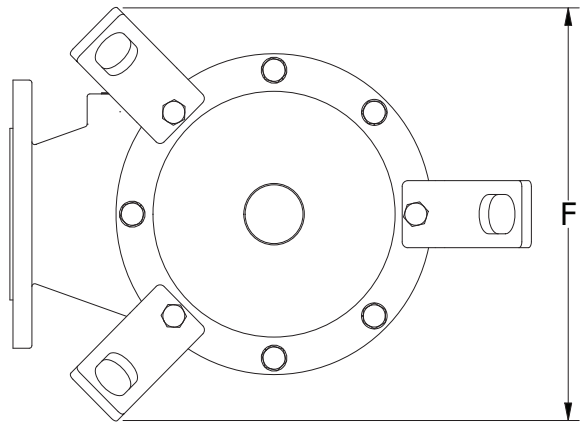

EXTENDED CONFIGURATION - TOP VIEW

DIMENSIONS CONT.
Aluminum, Carbon Steel & Stainless Steel Body

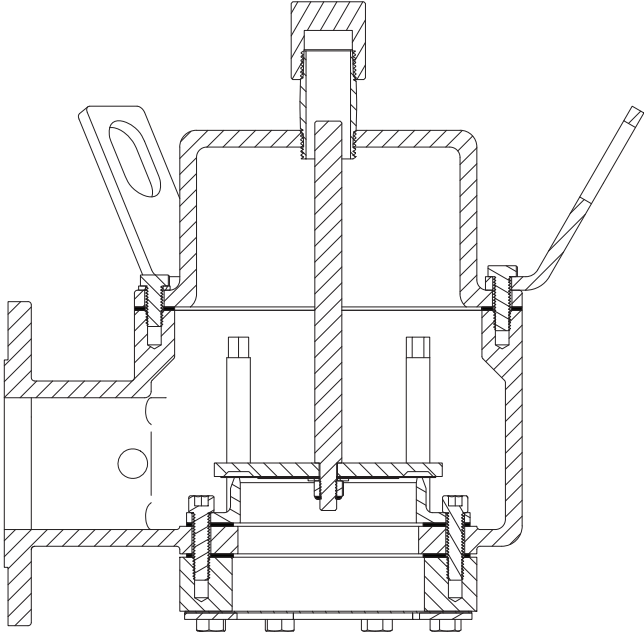
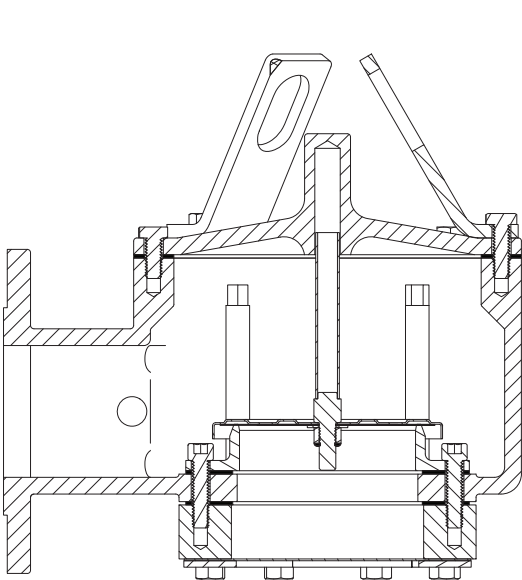

STANDARD CONFIGURATION - SECTION VIEW

EXTENDED CONFIGURATION - SECTION VIEW

Aluminum, Carbon Steel & Stainless Steel Construction										
SIZE (NPS)	DIMENSIONS (in.)						WEIGHT * (lbs)			
	A	B	C	D	E	F	STANDARD COVER		EXTENDED COVER	
							ALUM	CS/SST	ALUM	CS/SST
2	9 3/4	9 9/16	7 3/16	11 5/8	11 7/8	9 3/16	10	30	12	36
3	10 15/16	10 1/2	8	13 11/16	12 3/4	9 7/8	13	39	15	46
4	14 3/4	13 3/8	10 3/4	14 15/16	13 3/8	10 3/4	24	72	26	78
6	17 1/4	15 3/16	12 3/8	17 11/16	15 3/16	12 3/8	34	101	36	107
8	17 3/8	15 3/16	13 3/8	17 13/16	15 3/16	13 3/8	36	107	38	114
10	21 1/2	18 1/2	16	21 1/16	18 1/2	16	53	158	57	171
12	22 15/16	20 13/16	19	24 5/8	20 13/16	19	66	198	70	209
14	25 5/16	23 1/16	21	28 3/8	23 1/16	21	78	234	84	251

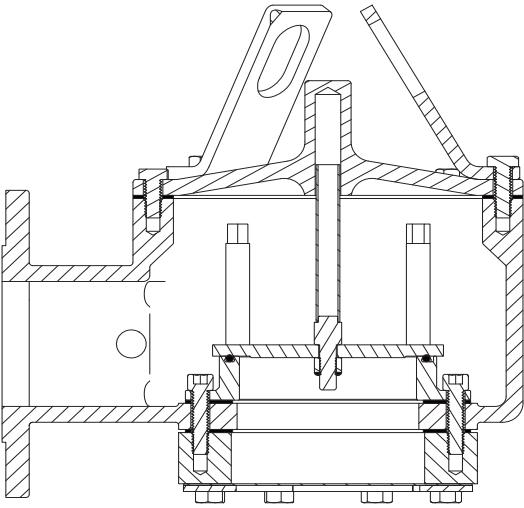

50 PSIG BACK PRESSURE - SECTION VIEW

Aluminum, Carbon Steel & Stainless Steel Body										
SIZE (DN)	DIMENSIONS (mm)						WEIGHT * (kg)			
	A	B	C	D	E	F	STANDARD COVER		EXTENDED COVER	
							ALUM	CS/SST	ALUM	CS/SST
50	248	243	183	295	302	233	5	14	5	16
80	278	267	203	348	324	251	6	18	7	21
100	375	340	273	379	340	273	11	33	12	35
150	438	386	314	449	386	314	15	46	16	49
200	441	386	340	452	386	340	16	49	17	52
250	546	470	406	535	470	406	24	72	26	78
300	583	529	483	625	529	483	30	90	32	95
350	643	586	533	721	586	533	35	106	38	114

* Estimated weight based on minimum set points. Weight will increase with higher set points and packaging.

DIMENSIONS
Corrosion Resistant Fiberglass (FRP) Body

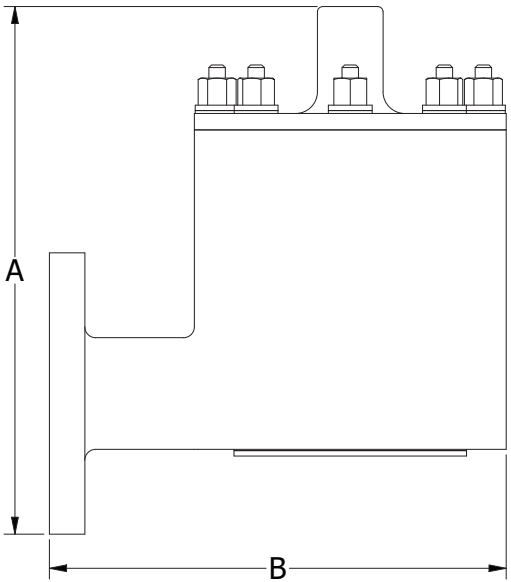

STANDARD CONFIGURATION - FRONT VIEW

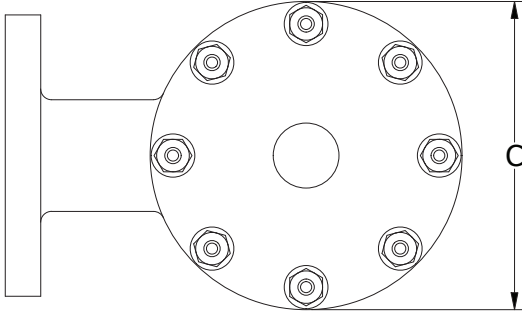

STANDARD CONFIGURATION - TOP VIEW

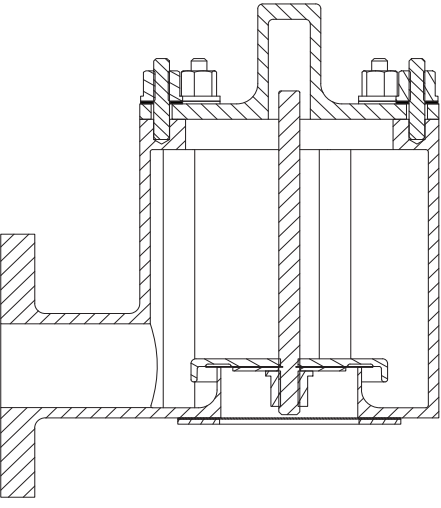

STANDARD CONFIGURATION - SECTION VIEW

FRP Construction				
SIZE (NPS)	DIMENSIONS (in.)			WEIGHT* (lbs)
	A	B	C	
2	11 15/16	11 11/16	8 3/8	6
3	12 1/4	11 11/16	8 3/8	7
4	15 3/8	15 3/8	12 3/4	10
6	16	15 7/8	12 3/4	14
8	16 1/4	15 7/8	13 1/2	15
10	20 1/4	20 3/8	16 3/4	20
12	22 3/8	20 3/16	19	26
14	25 3/16	22 1/4	21	32

SIZE (DN)	DIMENSIONS (mm)			WEIGHT* (kgs)
	A	B	C	
50	303	297	213	3
80	311	297	213	3
100	390	391	324	5
150	406	403	324	6
200	413	403	343	7
250	514	518	425	9
300	568	513	483	12
350	639	565	533	15

* Estimated weight based on minimum set points. Weight will increase with higher set points and packaging.

The contents of this publication are presented for informational purposes only, and while every effort has been made to ensure their accuracy, they are not to be construed as warranties or guarantees, express or implied, regarding the products or services described herein or their use or applicability. We reserve the right to modify or improve the designs or specifications of such product at any time without notice. Cashco, Inc. does not assume responsibility for the selection, use or maintenance of any product. Responsibility for proper selection, use and maintenance of any Cashco, Inc. product remains solely with the purchaser.

3600 Series PRODUCT CODE 07/18/22

3
6
POS 3
POS 4
POS 5
C
POS 7
0
POS 9
POS 10
POS 11
POS 12
0
0
0
0
0
0

POSITION 3 - FLANGE CONNECTION		
Standard Configuration	ASME 150	A
	PN16	B
	PN10	C
50 psig (3.4 barg) Back Pressure Configuration	ASME 150	D
	PN16	E
	PN10	F

POSITION 4 - FLANGE SIZE	
INCH (DN)	CODE
2 (DN50)	2
3 (DN80)	3
4 (DN100)	4
6 (DN150)	6
8 (DN200)	8
10 (DN250)	A
12 (DN300)	B

POSITION 5 - BODY/SEAT RING MATERIAL		
BODY MATERIAL	SEAT MATERIAL	CODE
Aluminum	Aluminum	1
Aluminum	316 Stainless Steel	4
Carbon Steel	316 Stainless Steel	5
316 Stainless Steel	316 Stainless Steel	6
304 Stainless Steel	304 Stainless Steel	7
Derakane 470 w/ SST Studs	Derakane 470	D
Derakane 470 w/ Hast C Studs	Derakane 470	E
Hetron 800 w/ SST Studs	Hetron 800	F
Hetron 800 w/ Hast C Studs	Hetron 800	G

POSITION 7 - SEAL MATERIAL	
FEP (Std)	A
Buna-N	B
EPDM	D
FKM	F

POSITION 9 - VACUUM PALLET CONFIGURATION		
Set Point Range		CODE
oz/in ²	mBar	
MIN - 0.49	MIN - 2.11	1
0.50 - 0.74	2.12 - 3.19	2
0.75 - 7.99	3.20 - 34.4	3
8.00 - MAX	34.5 - MAX	4

See Table 4 for MIN and MAX vacuum set points.

POSITION 10 - WEIGHT MATERIAL	
Epoxy Coated Carbon Steel	0
Stainless Steel	S
FRP Encapsulated Steel	E

POSITION 11 - VACUUM SCREEN	
Standard Screen	0
Flame Screen	F

POSITION 12 - CLEANING METHOD	
Standard Cleaning	0
Oxygen Cleaning	M

*** For information on ATEX see pages 12 & 13 on the IOM.**

Cashco, Inc.
 P.O. Box 6
 Ellsworth, KS 67439-0006
 PH (785) 472-4461
 Fax. # (785) 472-3539
 www.cashco.com
 email: sales@cashco.com
 Printed in U.S.A. 3300-TB

Cashco GmbH
 Handwerkerstrasse 15
 15366 Hoppegarten, Germany
 PH +49 3342 30968 0
 Fax. No. +49 3342 30968 29
 www.cashco.com
 email: germany@cashco.com

Cashco do Brasil, Ltda.
 Rua Bonifácio Cubas, 389.
 Cep 02731-000 – Vila Albertina - São Paulo - SP
 PH +55 11 99677 7177
 Fax. No.
 www.cashco.com
 email: brazil@cashco.com