



ISO Registered Company



MODEL HP

HIGH PRESSURE REDUCING REGULATOR



MODEL HP

OVERVIEW

The Model "HP" is a heavy duty, high pressure reducing regulator with balanced trim and a composition seat for controlling downstream pressure between 10–750 psig (.69 – 51.7 Barg) with inlet pressures up to 3000 psig (206 Barg). A metal seated version is also available. Where trim wear is expected, metal seating surfaces may be stellite. Sizes 1/2"–1-1/2" (DN15–40). Available options include differential construction, flanged end connections and NACE construction.

FEATURES

- High Pressure:** High inlet and outlet pressures; high pressure drops.
- Balanced Trim:** Minimizes the effect of large changes in inlet pressure such as those encountered with bottled gas.
- Tight Shutoff:** Composition seat provides bubble-tight shutoff.
- High Capacity:** Allows banking of bottled gas through one regulator
- Adjustment Ease:** Radial roller bearings to reduce frictional forces and wear on higher spring ranges.

APPLICATIONS

Designed primarily for controlling clean gases. Handles bottled gas up to 3000 psig (207 Barg) inlet pressure, with a maximum pressure drop of up to 2990 psid (206 Bard). Suitable for hydrogen.

Use in liquid service is for non-cavitating fluids up to 600 psid (41.4 Bard) pressure drop, metal seated.

CAUTION
DO NOT APPLY IN STEAM SERVICE



LINE SIZES AVAILABLE

1/2" (DN15), 3/4" (DN20) 1" (DN25)
1-1/2" (DN40)



END CONNECTIONS

FNPT, RF FLANGED, BSPT, EXTENDED
NIPPLES, 14" FACE TO FACE



COMMON APPLICATIONS

CLEAN GASES, BOTTLED GASES,
LIQUIDS, HYDROGEN



DESIGN PRESSURE

INLET: UP TO 3000 psig (207 Barg)
OUTLET: UP TO 750 psig (51.7Barg)

STANDARD/GENERAL SPECIFICATIONS

Body Sizes:	1/2", 3/4", 1", 1-1/2" (DN 15, 20, 25, 40).	Maximum Operating Capacity:	See Tables 8 through 13. Recommended practical limit of 20% droop. See Table 6 for maximum Cv and kv values.
Body Materials:	Mn Brz – Manganese Bronze. CS – Carbon Steel. SST – Stainless Steel. (See Table 1.)	Trim Designs:	Primarily 316 SST material. <u>Metal Seat</u> - Unbalanced; four material combinations. <u>Composition Seat</u> - Balanced; eight material combinations. See Tables 4 and 5.
End Connections:	NPT female, Opt-30: 300#,600#,900#,1500# RF flanged. Opt-31P: British Standard Parallel Thread. Opt-32: Extended plain end nipples. Opt-34: 14" Face to Face Flange Dim.	Range Springs:	<u>Standard:</u> Epoxy coated steel. <u>LCC Body material:</u> SST See Table 7.
Pressure/ Temperature Ratings:	See Table 1.	Gaskets:	<u>Standard</u> - Graphite/NBR - Diaphragm, Cylinder & Closing. Cap. <u>Alternate Material:</u> See Opt-45.
Inlet Temperature:	See Tables 1, 4, and 5.	Flange Bolting:	<u>Standard:</u> Heat treated zinc plated steel. <u>LLC body material:</u> SST.
Outlet Pressure:	<u>Standard</u> - Up to 325 psig (22.4 Barg), metal or composition diaphragm. <u>Option-80</u> - Up to 750 psig (51.7 Barg) metal diaphragm. See Tables 4 and 5.	Painting:	<u>Standard:</u> All non-corrosion resistant portions to be painted with corrosion resistant epoxy paint per Cashco Spec #S-1606.
Maximum Pressure Drop:	See Table 2.		

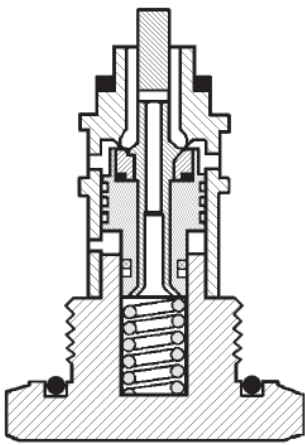

Figure 1:
Model HP Composition Seat,
Balanced Trim Design

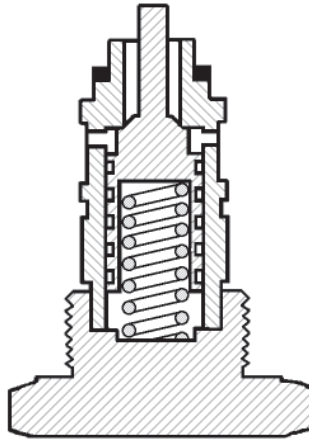

Figure 2:
Model HP Metal Seat,
Unbalanced Trim Design

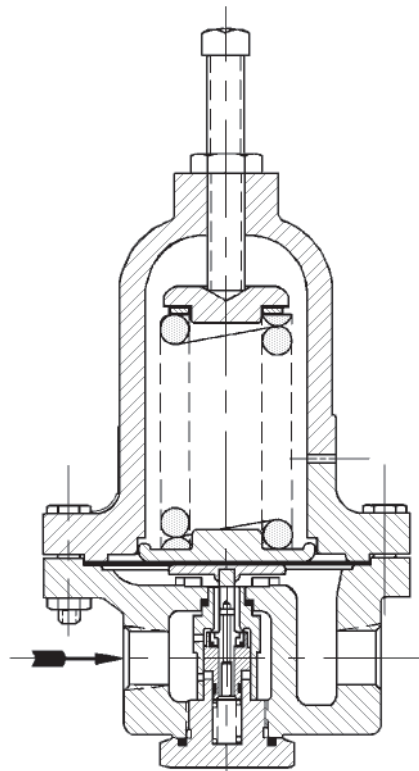

Figure 3:
Model HP Cut-away

OPTION SPECIFICATIONS

This section indicates special variations which are available to the standard Model HP product. Multiple options may be selected; i.e. HP-1+30, which is the standard HP product plus the -1 and the -30 Options together. Care must be exhibited to not develop conflicting combinations; i.e. a carbon steel HP-55.

Option -1: CLOSING CAP. Use to prevent tampering with the set point pressure. Available on all spring chamber materials. Consists of a ductile iron closing cap, a sealing gasket, a sealing lock nut on the adjusting screw, and a 1/4" (DN8) NPT female tapped spring chamber vent hole.

Option -1+6: DIFFERENTIAL CONSTRUCTION. For differential pressure service. Available only on manganese bronze or carbon steel spring chambers. Internal construction includes a large pusher plate and an extra diaphragm gasket (for metal diaphragms). See Table 7 for available range springs. Includes all parts as described in Opt-1.

Consult factory for sizing and selection of differential Model HP's.

⚠ CAUTION

Option-1+6 contains single diaphragm construction. In the event of diaphragm failure, the process fluid will mix with the loading fluid. Please alert your representative so an alternative product can be selected.

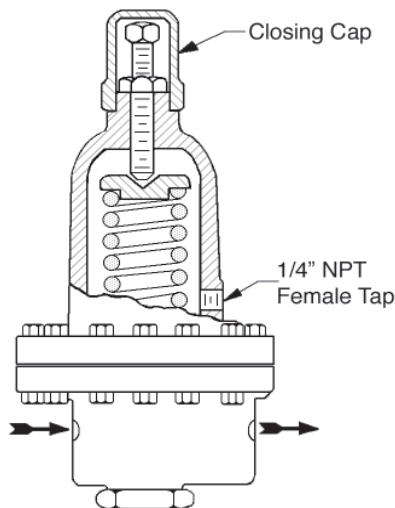

Figure 4: Model HP 1+6
Differential Construction w/Closing Cap

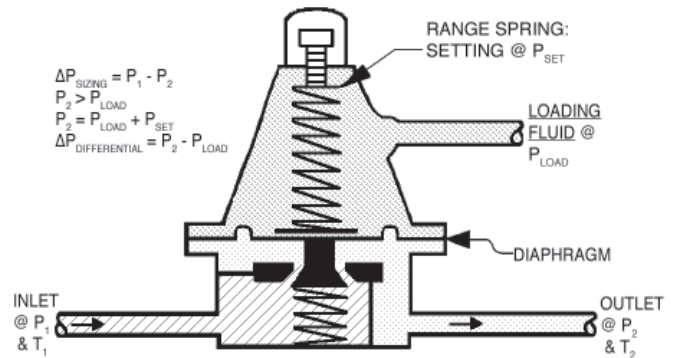

Figure 5: Model HP 1+6
Differential Schematic

Option -15: STELLITED SEATS. Stellite seating surfaces on unbalanced metal seating piston and cylinder. Can only be applied to Trim S1.

Option -25: TAPPED VENT. 1/4" (DN8) NPT tapped opening in spring chamber for piping vent to remote location, in the event of diaphragm failure.

Option -25P: PLASTIC RAIN PROOF BUG VENT. (For Opt-25).

Option -25S: SST RAIN PROOF BUG VENT. (For Opt-25).

Option -30: FLANGED END CONNECTIONS. Socket welded flanges available for ASME classes 300, 600, 900, and 1500 raised face flanges available for carbon steel or 316 SST bodies.

See dimension "H" on Dimension & Weight Table for face-to-face dimensions of flanged units.

- Option -31P:** BSPP END CONNECTIONS. British Standard Parallel Pipe threads per ISO 7/1; used as an alternate to NPT ends.
- Option -32:** EXTENDED NIPPLES. Schedule 160 plain end extension nipples available for carbon steel or 316 SST bodies. Refer to Table 11 for dimensions.
- Option -34:** SPECIAL 14" FACE TO FACE DIMENSION FOR FLANGED END CONNECTIONS. See Opt.-30 for standard face to face dimension.
- Option -40:** CS NACE CONSTRUCTION. Internal wetted portions meet NACE standard MR0175 when the exterior of the regulator is not directly exposed to a sour gas environment, buried, insulated or otherwise denied direct atmospheric exposure. CS/CS body/spring chamber materials with S40 trim only. (Alternate LCC body/spring chamber material with S40D or S40E only trim.)
- Option -40SST:** NACE CONSTRUCTION. Same as Option -40, except uses SST body. Spring chamber may be of carbon steel or 316 SST material.
- Option -45:** TFE/FKM GASKETS. Primarily for oxygen service. Utilizes TFE diaphragm gasket and fluorocarbon elastomer cylinder gasket over standard gaskets. Temperature range: -20°C to +400°F (-29° to +205°C).
- Option -55:** SPECIAL CLEANING. MnBrz or SST body materials only. Cleaning per Cashco specification S-1134 for gaseous oxygen service is compliant with CGA G-4.4. Recommended for use with M1 or M36 trims. **NOTE:** Design pressure rating shall not exceed 375 psig (25.8 Barg) and 400°F (200°C) when body material is SST and process medium is oxygen.
- Option -56:** SPECIAL CLEANING. Cleaned per Cashco Spec. #S-1542. Utilize when cleanliness level better than normal is required and unit is not for oxygen service. For all body materials. NOT suitable for Oxygen Service.
- Option-58:** SPECIAL CLEANING for gaseous hydrogen services per Cashco specification S-1821. Cleaning procedure is compliant with CGA G-5.4 and includes sealed enclosure bag and notification tag stating suitability for gaseous hydrogen service. Requires trim codes of S3Y, S9Y. or S36Y and Opt-25 tapped vent spring chamber.
- Option -80:** HIGH OUTLET PRESSURE. This option adds components to fully support the diaphragm for higher outlet pressures. Available with 1/2" - 1" (DN15-25) line sizes with metal diaphragm trim designations only. See Table 7 for available range springs. Not available for use with Option-1+6.

TECHNICAL SPECIFICATIONS

TABLE 1
PRESSURE/TEMPERATURE RATINGS
Pressure Boundary Components Only
NPT, BSPP, And Ext. Nipple Ratings Per ASME B31.3
Flange Ratings Per ASME B16.5

Body/Sp. Chamber	End Connection	Inlet Pressure		Outlet Pressure		Temperature		
		psig	(Barg)	psig	(Barg)	°F	(°C)	
MnBrz/MnBrz	NPT/BSPP	2590	(178)	950	(65.5)	-325 to +350	(-198 to 177)	
CS/CS LCC/LCC ¹	NPT BSPP Ext. Nipples	3000	(206)	950	(65.5)	-20 to +400	(-29 to +204)	
		2995	(206)	950	(65.5)	500	(260)	
		2810	(193)	950	(65.5)	600	(315)	
	Class 300 Flanges	740	(51.0)	740	(51.0)	-20 to +100	(-29 to +38)	
		680	(46.8)	680	(46.8)	200	(93)	
		655	(45.1)	655	(45.1)	300	(149)	
		635	(43.7)	635	(43.7)	400	(204)	
		605	(41.7)	605	(41.7)	500	(260)	
		570	(39.3)	570	(39.3)	600	(315)	
	Class 600 Flanges	1480	(102)	950	(65.5)	-20 to +100	(-29 to +38)	
		1360	(93.7)	950	(65.5)	200	(93)	
		1310	(90.3)	950	(65.5)	300	(149)	
		1265	(87.2)	950	(65.5)	400	(204)	
		1205	(83.1)	950	(65.5)	500	(260)	
	Class 900 Flanges	1135	(78.2)	950	(65.5)	600	(315)	
		2220	(153)	950	(65.5)	-20 to +100	(-29 to +38)	
		2035	(140)	950	(65.5)	200	(93)	
		1965	(135)	950	(65.5)	300	(149)	
		1900	(131)	950	(65.5)	400	(204)	
		1810	(124)	950	(65.5)	500	(260)	
	Class 1500 Flanges	1705	(117)	950	(65.5)	600	(315)	
		3000	(206)	950	(65.5)	-20 to +400	(-29 to +204)	
		2995	(206)	950	(65.5)	500	(260)	
	SST/CS SST/SST ²	NPT BSPP Ext. Nipples	2810	(193)	950	(65.5)	600	(315)
			3000	(206)	950	(65.5)	-20 to +200	(-29 to +93)
			2795	(192)	950	(65.5)	300	(149)
			2570	(177)	950	(65.5)	400	(204)
2390			(164)	950	(65.5)	500	(260)	
Class 300 Flanges		2255	(155)	950	(65.5)	600	(315)	
		720	(49.6)	720	(49.6)	-20 to +100	(-29 to +38)	
		620	(42.7)	620	(42.7)	200	(93)	
		560	(38.6)	560	(38.6)	300	(149)	
		515	(35.5)	515	(35.5)	400	(204)	
		480	(33.1)	480	(33.1)	500	(260)	
Class 600 Flanges		450	(31.0)	450	(31.0)	600	(315)	
		1440	(99.3)	950	(65.5)	-20 to +100	(-29 to +38)	
		1240	(85.5)	950	(65.5)	200	(93)	
		1120	(77.2)	950	(65.5)	300	(149)	
		1025	(70.6)	950	(65.5)	400	(204)	
		955	(65.8)	950	(65.5)	500	(260)	
Class 900 Flanges		900	(62.0)	900	(62.0)	600	(315)	
		2160	(148)	950	(65.5)	-20 to +100	(-29 to +38)	
		1860	(128)	950	(65.5)	200	(93)	
		1680	(115)	950	(65.5)	300	(149)	
		1540	(106)	950	(65.5)	400	(204)	
		1435	(98)	950	(65.5)	500	(260)	
Class 1500 Flanges		1355	(93)	950	(65.5)	600	(315)	
		3000	(206)	950	(65.5)	-20 to +200	(-29 to +93)	
		2795	(192)	950	(65.5)	300	(149)	
		2570	(177)	950	(65.5)	400	(204)	
	2390	(164)	950	(65.5)	500	(260)		
2255	(155)	950	(65.5)	600	(315)			

¹LCC/LCC has minimum temperature ratings of -50°F (-46°C).

²Ratings for SST/SST shall not exceed 375 psig (26 Barg) and 400°F (200°C) in oxygen service. (CGA G-4.4)

**TABLE 2
MAXIMUM ALLOWABLE PRESSURE DROPS**

Fluid	Clean Fluid - Indust. Quality		Unclean Fluid - Pipeline Quality		Seat Design	Trim Designation Number
	psid	(Bard)	psid	(Bard)		
Liquid	600	(41.4)	600	(41.4)	Metal - Stellite	S1
	600	(41.4)	400	(27.6)	Metal	S1, S40
	400	(27.6)	400	(27.6)	Composition TFE	S3, S9, S36, S3Y, S9Y, S36Y, S40D, S40E
Gas	2400	(166)	2400	(166)	Metal - Stellite	S1
	2400	(166)	600	(41.4)	Metal	S1, S40
	3000 @ -20°F to +70°F (-29°C to +21°C)	(207)	Not Recommended		PTFE	S3, S36, S40D, S40E, S9, S36B
	2500 @ 100°F (38°C)	(172)				
	2000 @ 150°F (65°C)	(137)				
	2990 @ +70°F to +200°F (+21°C to +93°C)	(207)	Not Recommended		Nylon MDS	S3Y, S9Y, S36Y

**TABLE 3
APPLICATIONS**

Fluid	Recommended Construction	Trim Designation No.
Air or Industrial Gases	Clean Fluid; Balanced; Composition Diaphragm & Seat	S3, S3Y
	Clean Fluid; Balanced; Metal Diaphragm & Composition Seat	S36, S36Y
Chemicals	Clean Fluid; Balanced; Composition Diaphragm & Seat	S3, S3Y
	Clean Fluid; Balanced; Metal Diaphragm & Composition Seat	S9, S9Y, S36, S36Y
	Unclean Fluid; Unbalanced; Metal Diaphragm & Seat	S0, S1
Sour Gas (NACE Service)	Unclean Fluid; Unbalanced; Composition Diaphragm & Metal Seat	S40
Hydrocarbon Gas or Liquids	Clean Fluid; Balanced; Composition Diaphragm & Seat	S3, S3Y
	Clean Fluid; Balanced; Metal Diaphragm & Composition Seat	S36, S36Y
	Unclean Fluid; Unbalanced; Metal Diaphragm & Seat	S1
Water and Condensate (35° - 180° F)	Balanced; Composition Diaphragm & Seat	S3, S3Y
	Balanced; Metal Diaphragm & Composition Seat	S36, S36Y

NOTE: Trim Designation Nos. in "boldface" are the most commonly used. Cashco, or its representatives may make recommendations or suggestions as to the suitability of certain trims for specific services. These are trims that have been used successfully in the past in similar applications. However, the user has final responsibility for materials selected.

**TABLE 4
UNBALANCED METAL SEATED TRIM MATERIALS¹**

Part	Trim Designation Number			
	S0	S1	S40	M1 (OXYGEN)
Diaphragm	PTFE Coated 302 SST	302 SST	Neoprene	302 SST
Diaphragm Gasket ²	Graphite/NBR	Graphite/NBR	--	Graphite/NBR
Cylinder	316 SST	316 SST	316 SST	Monel
Cylinder Gasket	Graphite/NBR	Graphite/NBR	Graphite/NBR	Graphite/NBR
Piston	316 SST	316 SST	316 SST	Monel
Piston Spring	17-7PH SST	17-7PH SST	Inconel X750	17-7PH SST
Pusher Plate	316 SST	316 SST	316 SST	316 SST
Temperature Range ³	-50 to +500°F (-46 to +260°C)	-50 to +600°F (-46 to +315°C)	-20 to +212°F (-29 to +100°C)	-50 to +600°F (-46 to +315°C)
Max Outlet Pressure Standard/Opt-81	350/750 psig (24.1/51.7 Barg)	350/750 psig (24.1/51.7 Barg)	350 psig (24.1 Barg)	350/750 psig (24.1/51.7 Barg)

¹Cashco does not recommend metal seated trim on any service where the down stream flow will be dead ended.

²Option-45 replaces Graphite/NBR gaskets with PTFE diaphragm gasket and FKM cylinder gasket 0 to 400°F (-17 to +204°C).

³Temperature range should be evaluated accordingly when using Option-45 gaskets for both minimum and maximum temperatures.

**TABLE 5
BALANCED SOFT SEATED TRIM MATERIALS**

Part	Trim Designation Number									
	S3 (AIR)	S3Y	S9	S9Y	S36	S36B	S36Y	M36 (OXYGEN)	S40D (NACE)	S40E (NACE)
Diaphragm	Neoprene	Neoprene	PTFE Coated 302 SST	PTFE Coated 302 SST	302 SST	302 SST	302 SST	302 SST	Neoprene	Elgiloy
Diaphragm Gasket ¹	--	--	Graphite/NBR	Graphite/NBR	Graphite/NBR	Graphite/NBR	Graphite/NBR	Graphite/NBR	--	Graphite/NBR
Cylinder	316 SST	316 SST	316 SST	316 SST	316 SST	316 SST	316 SST	Monel	316 SST	316 SST
Cylinder Gasket ¹	Graphite/NBR	Graphite/NBR	Graphite/NBR	Graphite/NBR	Graphite/NBR	Graphite/NBR	Graphite/NBR	Graphite/NBR	Graphite/NBR	Graphite/NBR
Piston	316 SST	316 SST	316 SST	316 SST	316 SST	316 SST	316 SST	Monel	316 SST	316 SST
Seat Disc	PTFE	NYLON MDS	PTFE	NYLON MDS	PTFE	PTFE	NYLON MDS	PTFE	PTFE	PTFE
Piston Spring	302 SST	302 SST	302 SST	302 SST	302 SST	302 SST	302 SST	302 SST	Inconel X750	Inconel X750
Pusher Plate	316 SST	316 SST	316 SST	316 SST	316 SST	316 SST	316 SST	316 SST	316 SST	316 SST
Quad Ring	FKM	FKM	FKM	FKM	FKM	BUNA-N3	FKM	FKM	BUNA-N3	BUNA-N3
Backup Ring	PTFE	PTFE	PTFE	PTFE	PTFE	PTFE	PTFE	PTFE	PTFE	PTFE
O-Ring	FKM	FKM	FKM	FKM	FKM	BUNA-N	FKM	FKM	BUNA-N	BUNA-N
Temperature Range ²	-15 to +212°F (-26 to 100°C)	-15 to +212°F (-26 to 100°C)	-15 to +400°F (-26 to +204°C)	-15 to +230°F (-26 to +110°C)	-15 to +400°F (-26 to +204°C)	-55 to +225°F (-48 to +107°C)	-15 to +230°F (-26 to +110°C)	-15 to +400°F (-26 to +204°C)	-55 to +250°F (-53 to +121°C)	-55 to +225°F (-48 to +107°C)
Max Outlet Pressure Standard/ Opt-81	350 psig (24.1 Barg)	350 psig (24.1 Barg)	350/750 psig (24.1/51.7 Barg)	350/750 psig (24.1/51.7 Barg)	350/750 psig (24.1/51.7 Barg)	350/750 psig (24.1/51.7 Barg)	350/750 psig (24.1/51.7 Barg)	350/750 psig (24.1/51.7 Barg)	350 psig (24.1 Barg)	350/750 psig (24.1/51.7 Barg)

¹Option-45 replaces Graphite/NBR gaskets with PTFE diaphragm gasket and FKM cylinder gasket 0 to 400°F (-17 to +204°C).
²Temperature range should be evaluated accordingly when using Option-45 gaskets for both minimum and maximum temperatures.
³FKM quad ring is replaced with BUNA-N o-ring.

**TABLE 6
WIDE OPEN CAPACITIES
FOR SAFETY RELIEF VALVE SIZING**

	Body Size inch (DN)	
	1/2", 3/4", 1" (15, 20, 25)	1-1/2" (40)
Max. Cv (kv)	1.8 (1.5)	5.5 (4.7)

**TABLE 7
RANGE SPRINGS**

Line Size	Construction	Range Spring	
		Psi	(Bar)
1/2" - 1" (DN15-25)	Standard	10-40	(0.69-2.76)
		30-150	(2.1-10.3)
		120-225	(8.3-15.5)
		180-325	(12.4-22.4)
	Option-80	260-425	(17.9-29.3)
		340-500	(23.4-34.5)
Option-1+6	10-40	(0.69-2.76)	
	30-150	(2.1-10.3)	
1-1/2" (DN40)	Standard	10-40	(0.69-2.76)
		30-100	(2.1-6.9)
		80-150	(5.5-10.3)
		120-225	(8.3-15.5)
	Option-1+6	180-325	(12.4-22.4)
		10-40	(0.69-2.76)
		30-100	(2.1-6.9)
		80-150	(5.5-10.3)

**TABLE 8
FLOW CAPACITY - C_v vs. DROOP - METAL DIAPHRAGM
(F_L = .945)**

Option	Outlet Pressure P ₂		Body Size - inch (DN)					
			1/2" (15)		3/4" & 1" (20, 25)		1-1/2" (40)	
	psig	(barg)	Droop		Droop		Droop	
10%			20%	10%	20%	10%	20%	
Standard - None	10	(.69)	.40	.75	.53	1.02	.78	1.55
	25	(1.7)	.50	.87	.67	1.18	.95	1.86
	40	(2.8)	.56	.99	.77	1.30	1.06	2.16
	50	(3.4)	.58	1.00	.79	1.32	1.13	2.28
	75	(5.2)	.60	1.02	.82	1.33	1.15	2.36
	100	(6.9)	.62	1.04	.85	1.34	1.18	2.45
	150	(10.3)	.66	1.43	.86	1.12	1.45	2.65
	200	(13.8)	.73	1.51	.99	1.18	1.50	2.91
Option-80	325	(22.4)	.83	1.32	1.13	1.69	1.70	3.43
	375	(25.9)	.70	1.16	1.04	1.54	N/A	N/A
	425	(29.3)	.75	1.22	1.05	1.60		
	500	(34.5)	.86	1.30	1.14	1.74		
	625	(43.1)	.91	1.35	1.21	1.76		
750	(51.7)	.96	1.37	1.26	1.80			

N/A: Not Available METRIC CONVERSION FACTOR: CF / 1.16= kv

TABLE 9
FLOW CAPACITY - C_v vs. DROOP - COMPOSITION DIAPHRAGM
(F_L = .945)

Option	Outlet Pressure P ₂		Body Size - inch (DN)					
			1/2" (15)		3/4" & 1" (20, 25)		1-1/2" (40)	
	psig	(barg)	Droop		Droop		Droop	
			10%	20%	10%	20%	10%	20%
Standard - None	10	(.69)	.57	1.00	.77	1.30	1.14	2.28
	25	(1.7)	.65	1.15	.92	1.42	1.32	2.79
	40	(2.8)	.77	1.23	1.04	1.58	1.51	3.11
	50	(3.4)	.78	1.25	1.07	1.60	1.60	3.25
	75	(5.2)	.80	1.27	1.10	1.63	1.64	3.33
	100	(6.9)	.83	1.30	1.13	1.66	1.66	3.43
	150	(10.3)	.88	1.12	1.19	1.75	1.90	3.69
	200	(13.8)	.97	1.24	1.31	1.56	2.06	3.76
	325	(22.4)	1.10	1.38	1.43	1.80	2.45	4.39

METRIC CONVERSION FACTOR: CF / 1.16= kv

TABLE 10
AIR CAPACITIES IN SCFH
ALL SIZES - METAL DIAPHRAGM
S.G. = 1.0 TEMP = 60 °F F_L = .945

Outlet Pressure - P ₂ (psig)	Inlet Pressure - P ₁ (psig)	1/2" (DN15) Body		3/4" (DN20) Body		1" (DN25) Body		1-1/2" (DN40) Body	
		10% Droop	20% Droop	10% Droop	20% Droop	10% Droop	20% Droop	10% Droop	20% Droop
10	100	1400	2700	1900	3600	1900	3600	2800	5500
	200	2800	5300	3800	7200	3800	7200	5500	11000
	300	4300	8000	5600	10800	5600	10800	8300	16500
	400	5700	SONIC	7500	SONIC	7500	14500	11100	22000
	500	7100	SONIC	9400	SONIC	9400	18100	13900	27500
	750	SONIC	SONIC	SONIC	SONIC	14200	SONIC	20800	41400
	1000	SONIC	SONIC	SONIC	SONIC	18900	SONIC	27800	55300
	1250	SONIC	SONIC	SONIC	SONIC	23700	SONIC	34900	SONIC
	1500	SONIC	SONIC	SONIC	SONIC	SONIC	SONIC	42000	SONIC
	1750	SONIC	SONIC	SONIC	SONIC	SONIC	SONIC	49100	SONIC
	2000	SONIC	SONIC	SONIC	SONIC	SONIC	SONIC	56300	SONIC
25	2250	SONIC	SONIC	SONIC	SONIC	SONIC	SONIC	63100	SONIC
	2500	SONIC	SONIC	SONIC	SONIC	SONIC	SONIC	SONIC	SONIC
	100	1800	3100	2400	4200	2400	4200	3400	6600
	200	3500	6200	4700	8400	4700	8400	6700	13200
	300	5300	9300	7100	12500	7100	12500	10100	19800
	400	7100	12300	9500	16700	9500	16700	13500	26400
	500	8900	SONIC	11900	21000	11900	21000	16900	33000
	750	SONIC	SONIC	17900	SONIC	17900	31500	25400	49700
	1000	SONIC	SONIC	SONIC	SONIC	23900	SONIC	33900	66400
	1250	SONIC	SONIC	SONIC	SONIC	30000	SONIC	42500	83200
	1500	SONIC	SONIC	SONIC	SONIC	36100	SONIC	51100	100100
	1750	SONIC	SONIC	SONIC	SONIC	SONIC	SONIC	59800	SONIC
	2000	SONIC	SONIC	SONIC	SONIC	SONIC	SONIC	68500	SONIC
2250	SONIC	SONIC	SONIC	SONIC	SONIC	SONIC	76900	SONIC	
2500	SONIC	SONIC	SONIC	SONIC	SONIC	SONIC	85200	SONIC	
2750	SONIC	SONIC	SONIC	SONIC	SONIC	SONIC	93300	SONIC	
3000	SONIC	SONIC	SONIC	SONIC	SONIC	SONIC	101200	SONIC	

NOTE: Where "SONIC" is indicated, flow will be approximately the last indicated value in the column above "SONIC". Outlet velocity with Schedule 160 pipe exceeds sonic velocity of 1118 fps. Additional flow cannot be obtained, and pipeline velocity is in excess of customary pipe velocity design limits.
METRIC CONVERSION FACTOR: psig / 14.5 = Barg; SCFH / 35.31 = Sm³/Hr; SCFH / 37.32 = Nm³/Hr.

TABLE 10 (Continued)
AIR CAPACITIES IN SCFH
ALL SIZES - METAL DIAPHRAGM
S.G. = 1.0 TEMP = 60 °F F_L = .945

Outlet Pressure - P ₂ (psig)	Inlet Pressure - P ₁ (psig)	1/2" (DN15) Body		3/4" (DN20) Body		1" (DN25) Body		1-1/2" (DN40) Body	
		10% Droop	20% Droop	10% Droop	20% Droop	10% Droop	20% Droop	10% Droop	20% Droop
40	100	1900	3400	2700	4500	2700	4500	3700	7500
	200	4000	7000	5500	9200	5500	9200	7500	15300
	300	6000	10500	8200	13800	8200	13800	1300	23000
	400	7900	14100	10900	18500	10900	18500	15000	30700
	500	9900	17600	13700	23100	13700	23100	18800	38400
	750	15000	SONIC	20600	SONIC	20600	34700	28300	57700
	1000	SONIC	SONIC	27500	SONIC	27500	46400	37800	77100
	1250	SONIC	SONIC	SONIC	SONIC	34400	SONIC	47400	96600
	1500	SONIC	SONIC	SONIC	SONIC	41400	SONIC	57100	116300
	1750	SONIC	SONIC	SONIC	SONIC	48500	SONIC	66700	136000
	2000	SONIC	SONIC	SONIC	SONIC	SONIC	SONIC	76500	SONIC
	2250	SONIC	SONIC	SONIC	SONIC	SONIC	SONIC	85800	SONIC
	2500	SONIC	SONIC	SONIC	SONIC	SONIC	SONIC	95100	SONIC
	2750	SONIC	SONIC	SONIC	SONIC	SONIC	SONIC	104100	SONIC
3000	SONIC	SONIC	SONIC	SONIC	SONIC	SONIC	112900	SONIC	
50	100	1900	3300	2600	4400	2600	4400	3800	7600
	200	4100	7100	5600	9300	5600	9300	8000	16100
	300	6200	10600	8400	14000	8400	14000	12000	24200
	400	8200	14200	11200	18700	11200	18700	16000	32400
	500	10300	17800	14000	23400	14000	23400	20100	40500
	750	15500	SONIC	21100	35300	21100	35300	30200	60900
	1000	20700	SONIC	28200	SONIC	28200	47100	40300	81400
	1250	SONIC	SONIC	35300	SONIC	35300	59100	50600	102000
	1500	SONIC	SONIC	SONIC	SONIC	42500	SONIC	60800	122700
	1750	SONIC	SONIC	SONIC	SONIC	49700	SONIC	71100	143500
	2000	SONIC	SONIC	SONIC	SONIC	57000	SONIC	81500	164500
	2250	SONIC	SONIC	SONIC	SONIC	63900	SONIC	91500	SONIC
	2500	SONIC	SONIC	SONIC	SONIC	SONIC	SONIC	101400	SONIC
	2750	SONIC	SONIC	SONIC	SONIC	SONIC	SONIC	110900	SONIC
3000	SONIC	SONIC	SONIC	SONIC	SONIC	SONIC	120400	SONIC	
75	100	1600	2700	2200	3600	2200	3600	3100	6300
	200	4200	7100	5700	9300	5700	9300	8000	16400
	300	6400	10800	8700	14100	8700	14100	12200	25100
	400	8500	14500	11600	18900	11600	18900	16300	33500
	500	10700	18100	14600	23600	14600	23600	20400	41900
	750	16000	27200	21900	35500	21900	35500	30700	63000
	1000	21400	SONIC	29300	47500	29300	47500	41100	84200
	1250	26800	SONIC	36700	SONIC	36700	59500	51400	105600
	1500	SONIC	SONIC	44100	SONIC	44100	71600	61900	127000
	1750	SONIC	SONIC	SONIC	SONIC	51600	83700	72400	148600
	2000	SONIC	SONIC	SONIC	SONIC	59200	SONIC	83000	170200
	2250	SONIC	SONIC	SONIC	SONIC	66400	SONIC	93100	191000
	2500	SONIC	SONIC	SONIC	SONIC	73600	SONIC	103200	211700
	2750	SONIC	SONIC	SONIC	SONIC	80500	SONIC	112900	231700
3000	SONIC	SONIC	SONIC	SONIC	87400	SONIC	122500	SONIC	

NOTE: Where "SONIC" is indicated, flow will be approximately the last indicated value in the column above "SONIC". Outlet velocity with Schedule 160 pipe exceeds sonic velocity of 1118 fps. Additional flow cannot be obtained, and pipeline velocity is in excess of customary pipe velocity design limits.
METRIC CONVERSION FACTOR: psig / 14.5 = Barg; SCFH / 35.31 = Sm³/Hr; SCFH / 37.32 = Nm³/Hr.

TABLE 10 (Continued)
AIR CAPACITIES IN SCFH
ALL SIZES - METAL DIAPHRAGM
S.G. = 1.0 TEMP = 60 °F F_L = .945

Outlet Pressure - P ₂ (psig)	Inlet Pressure - P ₁ (psig)	1/2" (DN15) Body		3/4" (DN20) Body		1" (DN25) Body		1-1/2" (DN40) Body	
		10% Droop	20% Droop	10% Droop	20% Droop	10% Droop	20% Droop	10% Droop	20% Droop
100	200	4100	6900	5700	8900	5700	8900	7900	16300
	300	6500	11000	9000	14100	9000	14100	12400	25800
	400	8800	14700	12100	19000	12100	19000	16700	34700
	500	11000	18500	15100	23800	15100	23800	21000	43500
	750	16600	27800	22700	35800	22700	35800	31500	65400
	1000	22100	37100	30300	47800	30300	47800	42100	87500
	1250	27700	SONIC	38000	59900	38000	59900	52800	109600
	1500	33400	SONIC	45700	SONIC	45700	72100	63500	131900
	1750	SONIC	SONIC	53500	SONIC	53500	84400	74300	154200
	2000	SONIC	SONIC	61300	SONIC	61300	96700	85100	176700
	2250	SONIC	SONIC	SONIC	SONIC	68800	108500	95500	198300
	2500	SONIC	SONIC	SONIC	SONIC	76200	SONIC	105900	219800
	2750	SONIC	SONIC	SONIC	SONIC	83400	SONIC	115800	240500
3000	SONIC	SONIC	SONIC	SONIC	90600	SONIC	125700	261100	
150	200	3500	7600	4600	6000	4600	6000	7800	14200
	300	6600	14300	8600	11200	8600	11200	14500	26500
	400	9200	19900	12000	15600	12000	15600	20200	36900
	500	11700	25300	15200	19800	15200	19800	25600	46800
	750	17600	38200	23000	29900	23000	29900	38700	70800
	1000	23600	51000	30700	40000	30700	40000	51800	94600
	1250	29500	SONIC	38500	50100	38500	50100	64900	118600
	1500	35500	SONIC	46300	60300	46300	60300	78000	142600
	1750	41600	SONIC	54100	70500	54100	70500	91300	166800
	2000	47600	SONIC	62000	80800	62000	80800	104600	191200
	2250	53400	SONIC	69600	90700	69600	90700	117400	214500
	2500	SONIC	SONIC	77100	SONIC	77100	105000	130100	237700
	2750	SONIC	SONIC	84400	SONIC	84400	110000	142300	260200
3000	SONIC	SONIC	91600	SONIC	91600	119300	154500	282400	
200	300	6500	13400	8800	10500	8800	10500	13400	25900
	400	9800	20200	13200	15800	13200	15800	20000	38900
	500	12700	26200	17200	20500	17200	20500	26000	50500
	750	19500	40200	26400	31500	26400	31500	40000	77600
	1000	26100	53900	35300	42100	35300	42100	53500	103900
	1250	32700	67600	44300	52800	44300	52800	67100	130200
	1500	39300	SONIC	53300	63500	53300	63500	80700	156600
	1750	46000	SONIC	62300	74300	62300	74300	94400	183200
	2000	52700	SONIC	71400	85100	71400	85100	108200	209900
	2250	59100	SONIC	80100	95500	80100	95500	121400	235500
	2500	65500	SONIC	88800	105900	88800	105900	134600	261000
	2750	SONIC	SONIC	97200	115800	97200	115800	147300	285700
3000	SONIC	SONIC	105500	SONIC	105500	125700	159800	310100	

NOTE: Where "SONIC" is indicated, flow will be approximately the last indicated value in the column above "SONIC". Outlet velocity with Schedule 160 pipe exceeds sonic velocity of 1118 fps. Additional flow cannot be obtained, and pipeline velocity is in excess of customary pipe velocity design limits.

METRIC CONVERSION FACTOR: psig / 14.5 = Barg; SCFH / 35.31 = Sm³/Hr; SCFH / 37.32 = Nm³/Hr.

TABLE 10 (Continued)
AIR CAPACITIES IN SCFH
ALL SIZES - METAL DIAPHRAGM
S.G. = 1.0 TEMP = 60 °F F_L = .945

Outlet Pressure - P ₂ (psig)	Inlet Pressure - P ₁ (psig)	1/2" (DN15) Body		3/4" (DN20) Body		1" (DN25) Body		1-1/2" (DN40) Body	
		10% Droop	20% Droop	10% Droop	20% Droop	10% Droop	20% Droop	10% Droop	20% Droop
325	400	7900	12600	10800	16100	10800	16100	16200	38200
	500	12500	19900	17100	25500	17100	25500	25700	51800
	750	21400	34100	29200	43600	29200	43600	43900	88500
	1000	29400	46700	40000	59800	40000	59800	60200	121400
	1250	37100	59000	50500	75500	50500	75500	75900	153200
	1500	44700	71000	60800	91000	60800	91000	91500	184600
	1750	52300	83100	71100	106400	71100	106400	107000	215900
	2000	59900	95200	81500	121900	81500	121900	122600	247400
	2250	67200	106800	91500	136800	91500	136800	137600	277600
	2500	74500	SONIC	101400	151600	101400	151600	152500	307700
	2750	81500	SONIC	110900	165900	110900	165900	166900	336700
3000	88400	SONIC	120400	180100	120400	180100	181100	365500	

NOTE: Where "SONIC" is indicated, flow will be approximately the last indicated value in the column above "SONIC". Outlet velocity with Schedule 160 pipe exceeds sonic velocity of 1118 fps. Additional flow cannot be obtained, and pipeline velocity is in excess of customary pipe velocity design limits.

METRIC CONVERSION FACTOR: psig / 14.5 = Barg; SCFH / 35.31 = Sm³/Hr; SCFH / 37.32 = Nm³/Hr.

TABLE 11
AIR CAPACITIES IN SCFH
ALL SIZES - COMPOSITION DIAPHRAGM
S.G. = 1.0 TEMP = 60 °F F_L = .945

Outlet Pressure - P ₂ (psig)	Inlet Pressure - P ₁ (psig)	1/2" (DN15) Body		3/4" (DN20) Body		1" (DN25) Body		1-1/2" (DN40) Body	
		10% Droop	20% Droop	10% Droop	20% Droop	10% Droop	20% Droop	10% Droop	20% Droop
10	100	2000	3500	2700	4600	2700	4600	4000	8100
	200	4000	7100	5500	9200	5500	9200	8100	16100
	300	6100	SONIC	8200	13800	8200	13800	12100	24200
	400	SONIC	SONIC	10900	SONIC	10900	18500	16200	32400
	500	SONIC	SONIC	13700	SONIC	13700	23100	20200	40500
	750	SONIC	SONIC	SONIC	SONIC	20600	SONIC	30400	60900
	1000	SONIC	SONIC	SONIC	SONIC	SONIC	SONIC	40700	SONIC
	1250	SONIC	SONIC	SONIC	SONIC	SONIC	SONIC	51000	SONIC
	1500	SONIC	SONIC	SONIC	SONIC	SONIC	SONIC	61400	SONIC
	1750	SONIC	SONIC	SONIC	SONIC	SONIC	SONIC	SONIC	SONIC
	2000	SONIC	SONIC	SONIC	SONIC	SONIC	SONIC	SONIC	SONIC
	2250	SONIC	SONIC	SONIC	SONIC	SONIC	SONIC	SONIC	SONIC

NOTE: Where "SONIC" is indicated, flow will be approximately the last indicated value in the column above "SONIC". Outlet velocity with Schedule 160 pipe exceeds sonic velocity of 1118 fps. Additional flow cannot be obtained, and pipeline velocity is in excess of customary pipe velocity design limits.

METRIC CONVERSION FACTOR: psig / 14.5 = Barg; SCFH / 35.31 = Sm³/Hr; SCFH / 37.32 = Nm³/Hr.

TABLE 11 (Continued)
AIR CAPACITIES IN SCFH
ALL SIZES - COMPOSITION DIAPHRAGM
S.G. = 1.0 TEMP = 60 °F F_L = .945

Outlet Pressure - P ₂ (psig)	Inlet Pressure - P ₁ (psig)	1/2" (DN15) Body		3/4" (DN20) Body		1" (DN25) Body		1-1/2" (DN40) Body	
		10% Droop	20% Droop	10% Droop	20% Droop	10% Droop	20% Droop	10% Droop	20% Droop
25	100	2300	4100	3300	5000	3300	5000	4700	9900
	200	4600	8100	6500	10100	6500	10100	9300	19800
	300	6900	12000	9800	15100	9800	15100	14000	29700
	400	9200	SONIC	13100	20200	13100	20200	18700	39600
	500	11500	SONIC	16300	SONIC	16300	25200	23400	49500
	750	SONIC	SONIC	SONIC	SONIC	24600	37900	35300	74500
	1000	SONIC	SONIC	SONIC	SONIC	32800	SONIC	47100	99600
	1250	SONIC	SONIC	SONIC	SONIC	SONIC	SONIC	59100	SONIC
	1500	SONIC	SONIC	SONIC	SONIC	SONIC	SONIC	71000	SONIC
	1750	SONIC	SONIC	SONIC	SONIC	SONIC	SONIC	83100	SONIC
	2000	SONIC	SONIC	SONIC	SONIC	SONIC	SONIC	95200	SONIC
	2250	SONIC	SONIC	SONIC	SONIC	SONIC	SONIC	SONIC	SONIC
	2500	SONIC	SONIC	SONIC	SONIC	SONIC	SONIC	SONIC	SONIC
2750	SONIC	SONIC	SONIC	SONIC	SONIC	SONIC	SONIC	SONIC	
40	100	2700	4200	3600	5500	3600	5500	5200	10700
	200	5500	8700	7400	11200	7400	11200	10700	22000
	300	8200	13100	11100	16800	11100	16800	16100	33100
	400	10900	17500	14800	22400	14800	22400	21400	44100
	500	13700	SONIC	18500	28100	18500	28100	26800	55200
	750	SONIC	SONIC	27800	SONIC	27800	42200	40300	83100
	1000	SONIC	SONIC	SONIC	SONIC	37100	SONIC	53900	111000
	1250	SONIC	SONIC	SONIC	SONIC	46500	SONIC	67600	139100
	1500	SONIC	SONIC	SONIC	SONIC	SONIC	SONIC	81300	SONIC
	1750	SONIC	SONIC	SONIC	SONIC	SONIC	SONIC	95100	SONIC
	2000	SONIC	SONIC	SONIC	SONIC	SONIC	SONIC	108900	SONIC
	2250	SONIC	SONIC	SONIC	SONIC	SONIC	SONIC	122200	SONIC
	2500	SONIC	SONIC	SONIC	SONIC	SONIC	SONIC	135500	SONIC
2750	SONIC	SONIC	SONIC	SONIC	SONIC	SONIC	SONIC	SONIC	
3000	SONIC	SONIC	SONIC	SONIC	SONIC	SONIC	SONIC	SONIC	
50	100	2600	4200	3600	5300	3600	5300	5300	10800
	200	5500	8800	7600	11300	7600	11300	11300	23000
	300	8300	13300	11400	17000	11400	17000	17000	34600
	400	11100	17700	15200	22700	15200	22700	22700	46100
	500	13900	SONIC	19000	28400	19000	28400	28400	57700
	750	20800	SONIC	28600	SONIC	28600	42700	42700	86800
	1000	SONIC	SONIC	SONIC	SONIC	38200	57100	57100	116000
	1250	SONIC	SONIC	SONIC	SONIC	47900	SONIC	71600	145400
	1500	SONIC	SONIC	SONIC	SONIC	57600	SONIC	86100	SONIC
	1750	SONIC	SONIC	SONIC	SONIC	SONIC	SONIC	100700	SONIC
	2000	SONIC	SONIC	SONIC	SONIC	SONIC	SONIC	115400	SONIC
	2250	SONIC	SONIC	SONIC	SONIC	SONIC	SONIC	129500	SONIC
	2500	SONIC	SONIC	SONIC	SONIC	SONIC	SONIC	143500	SONIC
2750	SONIC	SONIC	SONIC	SONIC	SONIC	SONIC	157100	SONIC	
3000	SONIC	SONIC	SONIC	SONIC	SONIC	SONIC	170500	SONIC	

NOTE: Where "SONIC" is indicated, flow will be approximately the last indicated value in the column above "SONIC". Outlet velocity with Schedule 160 pipe exceeds sonic velocity of 1118 fps. Additional flow cannot be obtained, and pipeline velocity is in excess of customary pipe velocity design limits.

METRIC CONVERSION FACTOR: psig / 14.5 = Barg; SCFH / 35.31 = Sm³/Hr; SCFH / 37.32 = Nm³/Hr.

TABLE 11 (Continued)
AIR CAPACITIES IN SCFH
ALL SIZES - COMPOSITION DIAPHRAGM
S.G. = 1.0 TEMP = 60 °F $F_L = .945$

Outlet Pressure - P ₂ (psig)	Inlet Pressure - P ₁ (psig)	1/2" (DN15) Body		3/4" (DN20) Body		1" (DN25) Body		1-1/2" (DN40) Body	
		10% Droop	20% Droop	10% Droop	20% Droop	10% Droop	20% Droop	10% Droop	20% Droop
75	100	2100	3400	2900	4400	2900	4400	4400	8900
	200	5600	8800	7700	11300	7700	11300	11400	23200
	300	8500	13500	11700	17300	11700	17300	17400	35400
	400	11400	18000	15600	23100	15600	23100	23300	47300
	500	14200	22600	19500	28900	19500	28900	29100	59100
	750	21400	SONIC	29400	43500	29400	43500	43800	88900
	1000	28600	SONIC	39300	SONIC	39300	58200	58500	118900
	1250	SONIC	SONIC	49200	SONIC	49200	72900	73400	149000
	1500	SONIC	SONIC	SONIC	SONIC	59200	87700	88300	179200
	1750	SONIC	SONIC	SONIC	SONIC	69300	SONIC	103200	209600
	2000	SONIC	SONIC	SONIC	SONIC	79400	SONIC	118300	SONIC
	2250	SONIC	SONIC	SONIC	SONIC	SONIC	SONIC	132700	SONIC
	2500	SONIC	SONIC	SONIC	SONIC	SONIC	SONIC	147100	SONIC
	2750	SONIC	SONIC	SONIC	SONIC	SONIC	SONIC	161000	SONIC
3000	SONIC	SONIC	SONIC	SONIC	SONIC	SONIC	174700	SONIC	
100	200	5500	8700	7500	11100	7500	11100	11100	22900
	300	8700	13700	11900	17500	11900	17500	17500	36100
	400	11800	18400	16000	23500	16000	23500	23500	48600
	500	14700	23100	20100	29500	20100	29500	29500	60900
	750	22200	34700	30200	44300	30200	44300	44300	91600
	1000	29600	SONIC	40300	59300	40300	59300	59300	122400
	1250	37100	SONIC	50600	SONIC	50600	74300	74300	153400
	1500	SONIC	SONIC	60800	SONIC	60800	89300	89300	184600
	1750	SONIC	SONIC	SONIC	SONIC	71100	104500	104500	215900
	2000	SONIC	SONIC	SONIC	SONIC	81500	SONIC	119700	247400
	2250	SONIC	SONIC	SONIC	SONIC	91500	SONIC	134400	277600
	2500	SONIC	SONIC	SONIC	SONIC	101400	SONIC	148900	SONIC
2750	SONIC	SONIC	SONIC	SONIC	110900	SONIC	163000	SONIC	
3000	SONIC	SONIC	SONIC	SONIC	SONIC	SONIC	176900	SONIC	
150	200	4700	6000	6400	9400	6400	9400	10200	19700
	300	8800	11200	11900	17500	11900	17500	19000	36900
	400	12300	15600	16600	24400	16600	24400	26500	51400
	500	15500	19800	21000	30900	21000	30900	33600	65200
	750	23500	29900	31800	46700	31800	46700	50700	98500
	1000	31400	40000	42500	62500	42500	62500	67800	131700
	1250	39400	50100	53200	78300	53200	78300	85000	165100
	1500	47400	SONIC	64000	SONIC	64000	94200	102300	198600
	1750	SONIC	SONIC	74900	SONIC	74900	110200	119600	232300
	2000	SONIC	SONIC	85800	SONIC	85800	126200	137100	266200
	2250	SONIC	SONIC	SONIC	SONIC	96300	141700	153800	298700
	2500	SONIC	SONIC	SONIC	SONIC	106700	157000	170400	331000
2750	SONIC	SONIC	SONIC	SONIC	116800	SONIC	186500	362200	
3000	SONIC	SONIC	SONIC	SONIC	126800	SONIC	202400	393200	

NOTE: Where "SONIC" is indicated, flow will be approximately the last indicated value in the column above "SONIC". Outlet velocity with Schedule 160 pipe exceeds sonic velocity of 1118 fps. Additional flow cannot be obtained, and pipeline velocity is in excess of customary pipe velocity design limits.
METRIC CONVERSION FACTOR: psig / 14.5 = Barg; SCFH / 35.31 = Sm³/Hr; SCFH / 37.32 = Nm³/Hr.

TABLE 11 (Continued)
AIR CAPACITIES IN SCFH
ALL SIZES - COMPOSITION DIAPHRAGM
S.G. = 1.0 TEMP = 60 °F $F_L = .945$

Outlet Pressure - P ₂ (psig)	Inlet Pressure - P ₁ (psig)	1/2" (DN15) Body		3/4" (DN20) Body		1" (DN25) Body		1-1/2" (DN40) Body	
		10% Droop	20% Droop	10% Droop	20% Droop	10% Droop	20% Droop	10% Droop	20% Droop
200	300	8600	11000	11700	13900	11700	13900	18300	33500
	400	13000	16600	17500	20800	17500	20800	27500	50200
	500	16800	21500	22700	27000	22700	27000	35700	65200
	750	25900	33000	34900	41600	34900	41600	54900	100200
	1000	34600	44300	46800	55700	46800	55700	73500	134200
	1250	43400	55500	58600	69800	58600	69800	92200	168200
	1500	52200	66700	70500	84000	70500	84000	110900	202400
	1750	61100	SONIC	82500	98200	82500	98200	129700	236700
	2000	SONIC	SONIC	94500	112500	94500	112500	148600	271200
	2250	SONIC	SONIC	106000	SONIC	106000	126300	166700	304300
	2500	SONIC	SONIC	117500	SONIC	117500	139900	184800	337300
	2750	SONIC	SONIC	SONIC	SONIC	128600	153100	202200	369100
3000	SONIC	SONIC	SONIC	SONIC	139600	166200	219500	400600	
325	400	10500	13200	13700	17200	13700	17200	23400	41900
	500	16600	20900	21600	27200	21600	27200	37000	66300
	750	28400	35600	36900	46500	36900	46500	63200	113300
	1000	38900	48900	50600	63700	50600	63700	86700	155400
	1250	49100	61600	63900	80400	63900	80400	109400	196100
	1500	59200	74300	77000	96900	77000	96900	131900	236300
	1750	69300	86900	90000	113300	90000	113300	154200	276400
	2000	79400	99500	103200	129800	103200	129800	176700	316700
	2250	89000	SONIC	115700	145700	115700	145700	198300	355300
	2500	98700	SONIC	128300	161500	128300	161500	219800	393800
	2750	108000	SONIC	140400	176700	140400	176700	240500	431000
	3000	SONIC	SONIC	152400	SONIC	152400	191800	261100	467800

NOTE: Where "SONIC" is indicated, flow will be approximately the last indicated value in the column above "SONIC". Outlet velocity with Schedule 160 pipe exceeds sonic velocity of 1118 fps. Additional flow cannot be obtained, and pipeline velocity is in excess of customary pipe velocity design limits.
METRIC CONVERSION FACTOR: psig / 14.5 = Barg; SCFH / 35.31 = Sm³/Hr; SCFH / 37.32 = Nm³/Hr.

TABLE 12
WATER CAPACITIES IN GPM
ALL SIZES - METAL DIAPHRAGM
S.G. = 1.0 TEMP = 60 °F $F_L = .945$

Outlet Pressure - P ₂ (psig)	Inlet Pressure - P ₁ (psig)	1/2" (DN15) Body		3/4" (DN20) Body		1" (DN25) Body		1-1/2" (DN40) Body	
		10% Droop	20% Droop	10% Droop	20% Droop	10% Droop	20% Droop	10% Droop	20% Droop
10	100	3.8	7.1	5.0	9.7	5.0	9.7	7.4	14.7
	150	4.7	8.9	6.3	12.1	6.3	12.1	9.2	18.3
	200	5.5	10.3	7.3	14.1	7.3	14.1	10.8	21.4
	250	CAV	CAV	CAV	CAV	CAV	CAV	CAV	CAV
25	100	4.3	7.5	5.8	10.2	5.8	10.2	8.2	16.1
	150	5.6	9.7	7.5	13.2	7.5	13.2	10.6	20.8
	200	6.6	11.5	8.9	15.6	8.9	15.6	12.6	24.6
	250	7.5	13.1	10.1	17.7	10.1	17.7	14.3	27.9
	300	8.3	14.4	11.1	19.6	11.1	19.6	15.8	30.8
	350	9.0	15.7	12.1	21.3	12.1	21.3	17.1	33.5
400	CAV	CAV	CAV	CAV	CAV	CAV	CAV	CAV	

NOTE: Where "CAV" is indicated, the water has reached full cavitation and flow is choked.
METRIC CONVERSION FACTOR: psig / 14.5 = Barg; GPM x 3.785 = LPM.

TABLE 12 (Continued)
WATER CAPACITIES IN GPM
ALL SIZES - METAL DIAPHRAGM
S.G. = 1.0 TEMP = 60 °F F_L = .945

Outlet Pressure - P ₂ (psig)	Inlet Pressure - P ₁ (psig)	1/2" (DN15) Body		3/4" (DN20) Body		1" (DN25) Body		1-1/2" (DN40) Body	
		10% Droop	20% Droop	10% Droop	20% Droop	10% Droop	20% Droop	10% Droop	20% Droop
40	100	4.3	7.7	6.0	10.1	6.0	10.1	8.2	16.7
	150	5.9	10.4	8.1	13.6	8.1	13.6	11.1	22.7
	200	7.1	12.5	9.7	16.4	9.7	16.4	13.4	27.3
	250	8.1	14.3	11.2	18.8	11.2	18.8	15.4	31.3
	300	9.0	16.0	12.4	21.0	12.4	21.0	17.1	34.8
	350	9.9	17.4	13.6	22.9	13.6	22.9	18.7	38.0
	400	10.6	18.8	14.6	24.7	14.6	24.7	20.1	41.0
	450	11.3	20.0	15.6	26.3	15.6	26.3	21.5	43.7
	500	CAV	CAV	CAV	CAV	CAV	CAV	CAV	CAV
50	100	4.1	7.1	5.6	9.3	5.6	9.3	8.0	16.1
	150	5.8	10.0	7.9	13.2	7.9	13.2	11.3	22.8
	200	7.1	12.2	9.7	16.2	9.7	16.2	13.8	27.9
	250	8.2	14.1	11.2	18.7	11.2	18.7	16.0	32.2
	300	9.2	15.8	12.5	20.9	12.5	20.9	17.9	36.0
	350	10.0	17.3	13.7	22.9	13.7	22.9	19.6	39.5
	400	10.9	18.7	14.8	24.7	14.8	24.7	21.1	42.7
	450	11.6	20.0	15.8	26.4	15.8	26.4	22.6	45.6
	500	12.3	21.2	16.8	28.0	16.8	28.0	24.0	48.4
750	CAV	CAV	CAV	CAV	CAV	CAV	CAV	CAV	
75	100	3.0	5.1	4.1	6.7	4.1	6.7	5.8	11.8
	150	5.2	8.8	7.1	11.5	7.1	11.5	10.0	20.4
	200	6.7	11.4	9.2	14.9	9.2	14.9	12.9	26.4
	250	7.9	13.5	10.8	17.6	10.8	17.6	15.2	31.2
	300	9.0	15.3	12.3	20.0	12.3	20.0	17.3	35.4
	350	9.9	16.9	13.6	22.1	13.6	22.1	19.1	39.1
	400	10.8	18.4	14.8	24.0	14.8	24.0	20.7	42.5
	450	11.6	19.8	15.9	25.8	15.9	25.8	22.3	45.7
	500	12.4	21.0	16.9	27.4	16.9	27.4	23.7	48.7
1000	CAV	CAV	CAV	CAV	CAV	CAV	CAV	CAV	
100	150	4.4	7.4	6.0	9.5	6.0	9.5	8.3	17.3
	200	6.2	10.4	8.5	13.4	8.5	13.4	11.8	24.5
	250	7.6	12.7	10.4	16.4	10.4	16.4	14.5	30.0
	300	8.8	14.7	12.0	19.0	12.0	19.0	16.7	34.6
	350	9.8	16.4	13.4	21.2	13.4	21.2	18.7	38.7
	400	10.7	18.0	14.7	23.2	14.7	23.2	20.4	42.4
	450	11.6	19.5	15.9	25.1	15.9	25.1	22.1	45.8
	500	12.4	20.8	17.0	26.8	17.0	26.8	23.6	49.0
750	15.8	26.5	21.7	34.2	21.7	34.2	30.1	62.5	

NOTE: Where "CAV" is indicated, the water has reached full cavitation and flow is choked.
 METRIC CONVERSION FACTOR: psig / 14.5 = Barg; GPM x 3.785 = LPM.
 (SIZE = MAX VELOCITY) 1/2" = 15fps, 3/4" = 17.5fps, 1" = 20fps, 1-1/2" = 25fps.

TABLE 12 (Continued)
WATER CAPACITIES IN GPM
ALL SIZES - METAL DIAPHRAGM
S.G. = 1.0 TEMP = 60 °F F_L = .945

Outlet Pressure - P ₂ (psig)	Inlet Pressure - P ₁ (psig)	1/2" (DN15) Body		3/4" (DN20) Body		1" (DN25) Body		1-1/2" (DN40) Body	
		10% Droop	20% Droop	10% Droop	20% Droop	10% Droop	20% Droop	10% Droop	20% Droop
150	200	4.7	10.1	6.1	7.9	6.1	7.9	10.3	18.7
	250	6.6	14.3	8.6	11.2	8.6	11.2	14.5	26.5
	300	8.1	17.5	10.5	13.7	10.5	13.7	17.8	32.5
	350	9.3	20.2	12.2	15.8	12.2	15.8	20.5	37.5
	400	10.4	22.6	13.6	17.7	13.6	17.7	22.9	41.9
	450	11.4	24.8	14.9	19.4	14.9	19.4	25.1	45.9
	500	12.3	26.8	16.1	21.0	16.1	21.0	27.1	49.6
	750	16.2	35.0	21.1	27.4	21.1	27.4	35.5	64.9
200	1000	19.2	41.7	25.1	32.7	25.1	32.7	42.3	77.3
	250	5.2	10.7	7.0	8.3	7.0	8.3	10.6	20.6
	300	7.3	15.1	9.9	11.8	9.9	11.8	15.0	29.1
	350	8.9	18.5	12.1	14.5	12.1	14.5	18.4	35.6
	400	10.3	21.4	14.0	16.7	14.0	16.7	21.2	41.2
	450	11.5	23.9	15.7	18.7	15.7	18.7	23.7	46.0
	500	12.6	26.2	17.1	20.4	17.1	20.4	26.0	50.4
	750	17.1	35.4	23.2	27.7	23.2	27.7	35.2	68.2
325	1000	20.6	42.7	28.0	33.4	28.0	33.4	42.4	82.3
	350	4.2	6.6	5.7	8.5	5.7	8.5	8.5	17.2
	400	7.2	11.4	9.8	14.6	9.8	14.6	14.7	29.7
	450	9.3	14.8	12.6	18.9	12.6	18.9	19.0	38.3
	500	11.0	17.5	14.9	22.4	14.9	22.4	22.5	45.4
	750	17.1	27.2	23.3	34.8	23.3	34.8	35.0	70.7
1000	21.6	34.3	29.4	43.9	29.4	43.9	44.2	89.1	

NOTE: Where "CAV" is indicated, the water has reached full cavitation and flow is choked.
 METRIC CONVERSION FACTOR: psig / 14.5 = Barg; GPM x 3.785 = LPM.

TABLE 13
WATER CAPACITIES IN GPM
ALL SIZES - COMPOSITION DIAPHRAGM
S.G. = 1.0 TEMP = 60 °F F_L = .945

Outlet Pressure - P ₂ (psig)	Inlet Pressure - P ₁ (psig)	1/2" (DN15) Body		3/4" (DN20) Body		1" (DN25) Body		1-1/2" (DN40) Body	
		10% Droop	20% Droop	10% Droop	20% Droop	10% Droop	20% Droop	10% Droop	20% Droop
10	100	5.4	9.5	7.3	12.3	7.3	12.3	10.8	21.6
	150	6.7	11.8	9.1	15.4	9.1	15.4	13.5	27.0
	200	7.9	13.8	10.6	17.9	10.6	17.9	15.7	31.4
	250	CAV	CAV	CAV	CAV	CAV	CAV	CAV	CAV
25	100	5.6	10.0	8.0	12.3	8.0	12.3	11.4	24.2
	150	7.3	12.9	10.3	15.9	10.3	15.9	14.8	31.2
	200	8.6	15.2	12.2	18.8	12.2	18.8	17.5	36.9
	250	9.8	17.3	13.8	21.3	13.8	21.3	19.8	41.9
	300	10.8	19.1	15.3	23.5	15.3	23.5	21.9	46.3
	350	11.7	20.7	16.6	25.6	16.6	25.6	23.8	50.3
	400	CAV	CAV	CAV	CAV	CAV	CAV	CAV	CAV

NOTE: Where "CAV" is indicated, the water has reached full cavitation and flow is choked.
 METRIC CONVERSION FACTOR: psig / 14.5 = Barg; GPM x 3.785 = LPM.
 (SIZE = MAX VELOCITY) 1/2" = 15fps, 3/4" = 17.5fps, 1" = 20fps, 1-1/2" = 25fps.

TABLE 13 (Continued)
WATER CAPACITIES IN GPM
ALL SIZES - COMPOSITION DIAPHRAGM
S.G. = 1.0 TEMP = 60 °F F_L = .945

Outlet Pressure - P ₂ (psig)	Inlet Pressure - P ₁ (psig)	1/2" (DN15) Body		3/4" (DN20) Body		1" (DN25) Body		1-1/2" (DN40) Body	
		10% Droop	20% Droop	10% Droop	20% Droop	10% Droop	20% Droop	10% Droop	20% Droop
40	100	6.0	9.5	8.1	12.2	8.1	12.2	11.7	24.1
	150	8.1	12.9	10.9	16.6	10.9	16.6	15.8	32.6
	200	9.7	15.6	13.2	20.0	13.2	20.0	19.1	39.3
	250	11.2	17.8	15.1	22.9	15.1	22.9	21.9	45.1
	300	12.4	19.8	16.8	25.5	16.8	25.5	24.3	50.1
	350	13.6	21.7	18.3	27.8	18.3	27.8	26.6	54.8
	400	14.6	23.3	19.7	30.0	19.7	30.0	28.7	59.0
	450	15.6	24.9	21.1	32.0	21.1	32.0	30.6	63.0
	500	CAV	CAV	CAV	CAV	CAV	CAV	CAV	CAV
50	100	5.5	8.8	7.6	11.3	7.6	11.3	11.3	23.0
	150	7.8	12.5	10.7	16.0	10.7	16.0	16.0	32.5
	200	9.6	15.3	13.1	19.6	13.1	19.6	19.6	39.8
	250	11.0	17.7	15.1	22.6	15.1	22.6	22.6	46.0
	300	12.3	19.8	16.9	25.3	16.9	25.3	25.3	51.4
	350	13.5	21.7	18.5	27.7	18.5	27.7	27.7	56.3
	400	14.6	23.4	20.0	29.9	20.0	29.9	29.9	60.8
	450	15.6	25.0	21.4	32.0	21.4	32.0	32.0	65.0
	500	16.5	26.5	22.7	33.9	22.7	33.9	33.9	68.9
750	CAV	CAV	CAV	CAV	CAV	CAV	CAV	CAV	
75	100	4.0	6.4	5.5	8.2	5.5	8.2	8.2	16.7
	150	6.9	11.0	9.5	14.1	9.5	14.1	14.2	28.8
	200	8.9	14.2	12.3	18.2	12.3	18.2	18.3	37.2
	250	10.6	16.8	14.6	21.6	14.6	21.6	21.7	44.1
	300	12.0	19.1	16.5	24.5	16.5	24.5	24.6	50.0
	350	13.3	21.1	18.2	27.0	18.2	27.0	27.2	55.2
	400	14.4	22.9	19.8	29.4	19.8	29.4	29.6	60.0
	450	15.5	24.6	21.3	31.6	21.3	31.6	31.8	64.5
	500	16.5	26.2	22.7	33.6	22.7	33.6	33.8	68.6
750	20.8	33.0	28.6	42.3	28.6	42.3	42.6	86.5	
100	150	5.9	9.2	8.0	11.7	8.0	11.7	11.7	24.3
	200	8.3	13.0	11.3	16.6	11.3	16.6	16.6	34.3
	250	10.2	15.9	13.8	20.3	13.8	20.3	20.3	42.0
	300	11.7	18.4	16.0	23.5	16.0	23.5	23.5	48.5
	350	13.1	20.6	17.9	26.2	17.9	26.2	26.2	54.2
	400	14.4	22.5	19.6	28.8	19.6	28.8	28.8	59.4
	450	15.5	24.3	21.1	31.1	21.1	31.1	31.1	64.2
	500	16.6	26.0	22.6	33.2	22.6	33.2	33.2	68.6
750	21.2	33.1	28.8	42.3	28.8	42.3	42.3	87.4	

NOTE: Where "CAV" is indicated, the water has reached full cavitation and flow is choked.
 METRIC CONVERSION FACTOR: psig / 14.5 = Barg; GPM x 3.785 = LPM.
 (SIZE = MAX VELOCITY) 1/2" = 15fps, 3/4" = 17.5fps, 1" = 20fps, 1-1/2" = 25fps.

TABLE 13 (Continued)
WATER CAPACITIES IN GPM
ALL SIZES - COMPOSITION DIAPHRAGM
S.G. = 1.0 TEMP = 60 °F F_L = .945

Outlet Pressure - P ₂ (psig)	Inlet Pressure - P ₁ (psig)	1/2" (DN15) Body		3/4" (DN20) Body		1" (DN25) Body		1-1/2" (DN40) Body	
		10% Droop	20% Droop	10% Droop	20% Droop	10% Droop	20% Droop	10% Droop	20% Droop
150	200	6.2	7.9	8.4	12.4	8.4	12.4	13.4	26.1
	250	8.8	11.2	11.9	17.5	11.9	17.5	19.0	36.9
	300	10.8	13.7	14.6	21.4	14.6	21.4	23.3	45.2
	350	12.4	15.8	16.8	24.7	16.8	24.7	26.9	52.2
	400	13.9	17.7	18.8	27.7	18.8	27.7	30.0	58.3
	450	15.2	19.4	20.6	30.3	20.6	30.3	32.9	63.9
	500	16.5	21.0	22.3	32.7	22.3	32.7	35.5	69.0
	750	21.6	27.4	29.1	42.9	29.1	42.9	46.5	90.4
200	250	6.9	8.8	9.3	11.0	9.3	11.0	14.6	26.6
	300	9.7	12.4	13.1	15.6	13.1	15.6	20.6	37.6
	350	11.9	15.2	16.0	19.1	16.0	19.1	25.2	46.1
	400	13.7	17.5	18.5	22.1	18.5	22.1	29.1	53.2
	450	15.3	19.6	20.7	24.7	20.7	24.7	32.6	59.5
	500	16.8	21.5	22.7	27.0	22.7	27.0	35.7	65.1
	750	22.7	29.1	30.7	36.6	30.7	36.6	48.3	88.2
	1000	27.4	35.1	37.1	44.1	37.1	44.1	58.3	106.3
325	350	5.5	6.9	7.2	9.0	7.2	9.0	12.3	22.0
	400	9.5	12.0	12.4	15.6	12.4	15.6	21.2	38.0
	450	12.3	15.4	16.0	20.1	16.0	20.1	27.4	49.1
	500	14.6	18.3	18.9	23.8	18.9	23.8	32.4	58.1
	750	22.7	28.4	29.5	37.1	29.5	37.1	50.5	90.5
	1000	28.6	35.9	37.2	46.8	37.2	46.8	63.7	114.1

NOTE: Where "CAV" is indicated, the water has reached full cavitation and flow is choked.
METRIC CONVERSION FACTOR: psig / 14.5 = Barg; GPM x 3.785 = LPM.
(SIZE = MAX VELOCITY) 1/2" = 15fps, 3/4" = 17.5fps, 1" = 20fps, 1-1/2" = 25fps.

DIMENSIONS AND WEIGHT

Size In.	Dimensions - Inches										Ship Weight (Lb.)
	A	B	C	D	E	F	G	H *	H **	H ***	
1/2"	4.38	11.38	11.63	1.94	6.25	3.54	2.62	12.00	12.25	14.00	26
3/4" & 1"	4.38	11.38	11.63	1.94	6.25	3.54	2.62	13.00	13.00	14.00	30
1-1/2"	6.69	11.62	13.00	2.19	7.62	3.84	3.69	15.00	15.00	14.00	56
Size (DN)	Dimensions - Millimeters										Ship Weight (Kg.)
	A	B	C	D	E	F	G	H *	H **	H ***	
(15)	111	289	295	49	159	89	67	305	311	356	12
(20, 25)	111	289	295	49	159	89	67	330	330	356	14
(40)	170	295	330	56	194	98	94	381	381	356	25

* Opt-30 Face-to-Face with flanged connections, all pressure classes, .
 ** Opt-32. Plain end nipples,
 *** Opt-34 Special 14" face to face flanged dim.

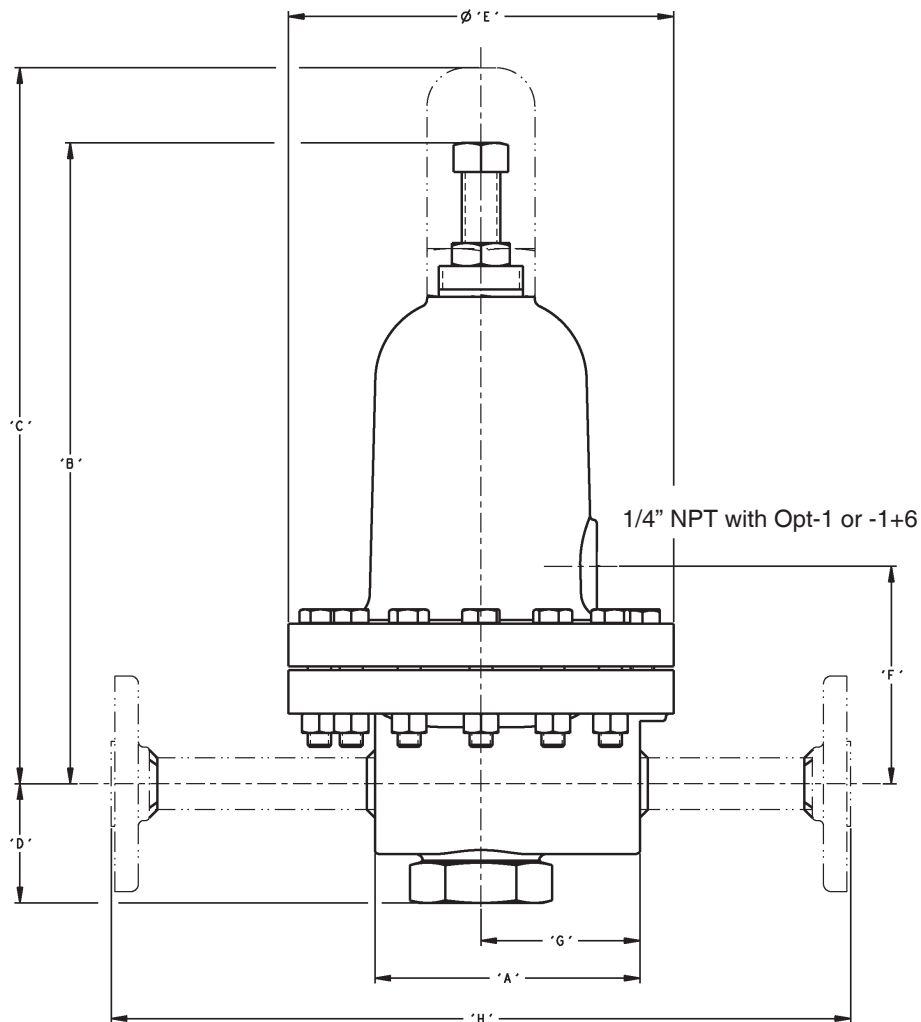

The contents of this publication are presented for informational purposes only, and while every effort has been made to ensure their accuracy, they are not to be construed as warranties or guarantees, express or implied, regarding the products or services described herein or their use or applicability. We reserve the right to modify or improve the designs or specifications of such product at any time without notice. Cashco, Inc. does not assume responsibility for the selection, use or maintenance of any product. Responsibility for proper selection, use and maintenance of any Cashco, Inc. product remains solely with the purchaser.

SPECIAL Coder for Cast Steel (LCC) Material

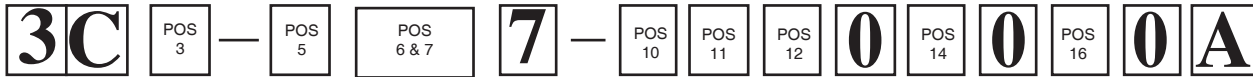

POSITION 3 - SIZES		
Size		CODE
in	(DN)	
1/2"	(15)	4
3/4"	(20)	5
1"	(25)	6
1-1/2"	(40)	8

POSITION 5 - BODY / SPRING CHAMBER MATERIALS	
Body / Sp. Ch.	CODE
LCC/LCC	D
SST/SST	A

POSITION 6 & 7 - TRIM DESIGNATION NUMBERS			
Unbalanced		Balanced	
Desig.	CODE	Desig.	CODE
S1	S1	S36B	6B
		S40D	4D (NACE)
		S40E	4E (NACE)

POSITION 10 - END CONNECTIONS	
Description	CODE
NPT - Screwed	1
-30 Opt.- 300 LB RF Flgs.	7
-30 Opt.- 600 LB RF Flgs.	8
-30 Opt.- 1500 LB RF Flgs.	A

POSITION 11- RANGE SPRINGS			
Size	psig	(Barg)	CODE
All	10-40	(.69-2.76)	1
1/2"-1"	30-150	(2.1-10.3)	2
1-1/2"	30-100	(2.1-6.9)	3
	80-150	(5.5-10.3)	4
All	120-225	(8.3-15.5)	5
	180-325	(12.4-22.4)	6
1/2"-1"	260-425	(17.9-29.3)	7
	340-500	(23.4-34.5)	8
	400-750	(27.6-51.7)	9

*** For information on ATEX see pages 8 & 9 on the IOM.**

POSITION 12 - TRIM OPTIONS		
Description	Option	CODE
No Option	---	0
Stellited Seat Surface - S1 Trim Only.	-15	A

POSITION 14 - SPRING CHAMBER OPTIONS		
Description	Option	CODE
No Option	---	0
1/4" (DN8) NPT Vent Tap.	-25	E

POSITION 16 - CERTIFICATE OPTIONS		
Description	Option	CODE
No Option	---	0
NACE Const: CS/CS/XX Per MR0175, S40D, S40E Trims.	-40	J
NACE Const: SST/SST/XX Per MR0175, S40D, S40E Trims	-40SST	K
Cleaned for hydrogen service per Cashco specification S-1821	-58	R

MODEL HP PRODUCT CODER 03/31/22

3 POS 2 POS 3 POS 5 POS 6 & 7 7 POS 10 POS 11 POS 12 POS 13 POS 14 0 POS 16 0 A

POSITION 2 - GASKETS * & SERVICE		
Gaskets - Service	Options	CODE
Standard : Graphite/NBR - Non-Oxygen	--	B
TFE / FKM - Primarily for Oxygen	-45	D

POSITION 3 - SIZE		
Size		CODE
in	(DN)	
1/2"	(15)	4
3/4"	(20)	5
1"	(25)	6
1-1/2"	(40)	8

POSITION 5 - BODY / SPRING CHAMBER MATERIALS	
Body / Sp. Ch.	CODE
MnBRZ/MnBRZ	B
CS/CS (WCB)	5
SST/CS	9
SST/SST	A

POSITION 6 & 7 - TRIM DESIGNATION NUMBERS			
Unbalanced		Balanced	
Stainless Steel Trim		Stainless Steel Trim	
Desig.	CODE	Desig.	CODE
S0	S0	S3	S3
S1	S1	S3Y	3Y
S40	40	S36	36
Monel Trim		S36B	6B
		S36Y	6Y
		S40D	4D
		S40E	4E
		S9	S9
		S9Y	9Y
		Monel Trim	
		Desig.	CODE
		M36	M6

POSITION 10 - END CONNECTIONS	
Description	CODE
NPT - Screwed	1
-30 Opt.- 300 LB RF Flgs.	7
-30 Opt.- 600 LB RF Flgs.	8
-30 Opt.- 900 LB RF Flgs.	9
-30 Opt.- 1500 LB RF Flgs.	A
-31P Opt.- BSPP - British Standard Parallel Pipe Thread	P
-32 Opt. - SCH. 160 PE Ext. Nipples	F
-34 Opt. - 300 LB RF Flgs. 14" F to F Dim.	W
-34 Opt. - 600 LB RF Flgs. 14" F to F Dim.	Y
-34 Opt. - 900 LB RF Flgs. 14" F to F Dim.	Z
-34 Opt. - 1500 LB RF Flgs. 14" F to F Dim.	U

POSITION 11 - RANGE SPRINGS			
Size	psig	(Barg)	CODE
All	10-40	(.69-2.76)	1
1/2"-1"	30-150	(2.1-10.3)	2
1-1/2"	30-100	(2.1-6.9)	3
	80-150	(5.5-10.3)	4
All	120-225	(8.3-15.5)	5
	180-325	(12.4-22.4)	6
1/2"-1"	260-425	(17.9-29.3)	7
	340-500	(23.4-34.5)	8
	400-750	(27.6-51.7)	9

POSITION 12 - TRIM OPTIONS		
Description	Option	CODE
No Option	---	0
Stellited Seat Surface - S1 Trim Only.	-15	A

POSITION 13 - FEATURE OPTIONS		
Description	Option	CODE
No Option	---	0
Closing Cap.	-1	1
Diff. Construction includes Closing Cap, MnBRZ & CS Spring Chamber only.	-1+6	8

POSITION 14 - SPRING CHAMBER OPTIONS		
Description	Option	CODE
No Option	---	0
1/4" (DN8) NPT Vent Tap .	-25	E
Plastic Rain-proof Bug Vent (includes Opt-25).	-25P	P
SST Rain-proof Bug Vent (includes Opt-25).	-25S	H

POSITION 16 - CERTIFICATE OPTIONS		
Description	Option	CODE
No Option	---	0
NACE Const: CS/CS/XX Per MR0175, S40, S40D, S40E Trims	-40	J
NACE Const: SST/SST/XX Per MR0175, S40, S40D, S40E Trims	-40SST	K
Special Cleaning: Per Cashco Spec #S-1134. W/ properly selected mat'ls. Suitable for Oxygen Service. BRZ or SST body material.	-55	M
Special Cleaning: Per Cashco Spec #S-1542. .	-56	N
Cleaned For Hydrogen Service Per Cashco Specification S-1821	-58	R

*** For information on ATEX see pages 8 & 9 on the IOM.**

Cashco, Inc.
P.O. Box 6
Ellsworth, KS 67439-0006
PH (785) 472-4461
Fax. # (785) 472-3539
www.cashco.com
email: sales@cashco.com
Printed in U.S.A. HP-TB

Cashco GmbH
Handwerkerstrasse 15
15366 Hoppegarten, Germany
PH +49 3342 30968 0
Fax. No. +49 3342 30968 29
www.cashco.com
email: germany@cashco.com

Cashco do Brasil, Ltda.
Al.Venus, 340
Indaiatuba - Sao Paulo, Brazil
PH +55 11 99677 7177
Fax. No.
www.cashco.com
email: brazil@cashco.com