



ISO Registered Company

MODELS 8310HP AND 8310LP PRESSURE REDUCING REGULATORS

SECTION I

I. DESCRIPTION AND SCOPE

The Model 8310 is a high capacity pressure reducing regulator with double seat design used to control downstream (outlet or P₂) pressure. Sizes are 1-1/2" (DN40), 2" (DN50), 2-1/2" (DN65), 3" (DN80) and 4" (DN100). With proper trim utilization, the unit is suitable for liquid, gaseous, or steam service. Refer to Technical Bulletin 8310-TB for design conditions and selection recommendations.

SECTION II

II. INSTALLATION



CAUTION

For welded installations, all internal trim parts, seals and diaphragm(s) must be removed from regulator body prior to welding into pipeline. The heat of fusion welding will damage non-metallic parts if not removed.

NOTE: This does not apply to units equipped with extended pipe nipples.

1. An inlet block valve should always be installed.
2. If service application is continuous such that shut down is not readily accomplished, it is recommended that an inlet block valve, outlet block valve, and a manual bypass valve be installed.
3. Pipe unions are recommended for NPT screwed installations to allow removal from piping.
4. An outlet pressure gauge should be located approximately ten pipe diameters downstream, and within sight.
5. All installations should include a downstream relief device if the inlet pressure could exceed the pressure rating of any downstream equipment or the maximum outlet pressure rating of the unit.



CAUTION

Installation of adequate overpressure protection is recommended to protect the regulator and all downstream equipment from damage in the event of regulator failure.

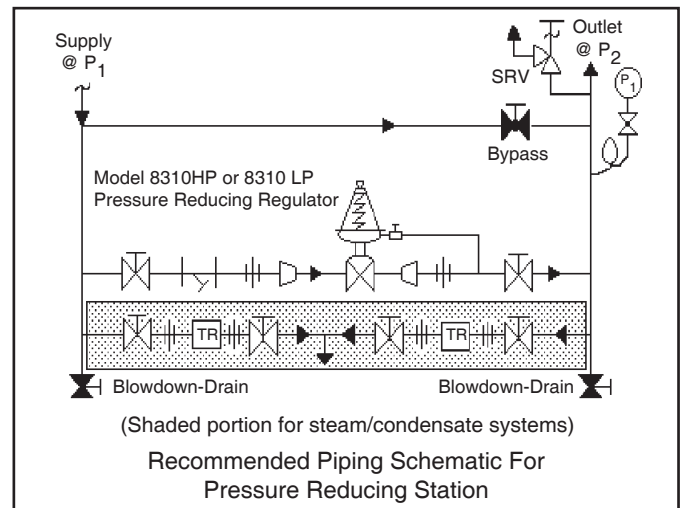

6. Clean the piping of all foreign material including chips, welding scale, oil, grease and dirt before installing the regulator. Strainers are recommended.
7. In placing thread sealant on pipe ends prior to engagement, ensure that excess material is removed and not allowed to enter the regulator upon start-up.
8. Flow Direction: Install so the flow direction matches the arrow cast on the body. Install an external sensing line (1/2" O.D. (DN15) tubing minimum) from the 3/8" (DN10) NPT connection in needle valve (39) to a point downstream, preferably at gauge location. If regulator pipe line is expanding to a larger pipe line, always connect sensing line to the larger pipe line.
9. For best performance, install in well drained horizontal pipe, properly trapped, if a steam service application.

10. Basic Regulator - (Refer to Figure 1): Regulator may be rotated around the pipe axis 360°. Recommended position is with spring chamber vertical upwards. Orient such that the spring chamber vent hole does not collect rainwater or debris.
11. Regulators are not to be direct buried underground.
12. For insulated piping systems, recommendation is to not insulate regulator.

 CAUTION
<p>DO NOT HYDROSTATIC TEST THROUGH AN INSTALLED UNIT; ISOLATE REGULATOR FROM TEST. The upper range spring pressure level listed on the nameplate is the recommended “upper operative limit” for the sensing diaphragm (see Section IV. Start-up, Number 7.) Higher pressures could cause internal damage. In addition, note on the nameplate that the Inlet and Outlet pressure and temperature ratings are at different levels.</p>

SECTION III

III. PRINCIPLE OF OPERATION

1. Movement occurs as pressure variations register on the diaphragm. The registering pressure is the outlet P_2 or downstream pressure. The range spring opposes diaphragm movement. As outlet pressure drops, the

range spring pushes the diaphragm down, opening the ports; as outlet pressure increases, the diaphragm pushes up and the port opening closes.

2. A complete diaphragm failure will cause the regulator to fail open.

SECTION IV

IV. START-UP

1. Start with the block valves closed. A bypass valve may be used to maintain outlet pressure in the downstream system without changing the following steps.
2. Relax the range spring by turning the adjusting screw counter clockwise (CCW) (viewed from above) a minimum of three (3) full revolutions. This reduces the outlet (downstream) pressure setpoint.
3. If it is a “hot” piping system, and equipped with a bypass valve, slowly open the bypass valve to preheat the system piping and to allow slow expansion of the piping. Ensure proper steam trap operation, if installed. Closely monitor outlet (downstream) pressure via gauge to ensure not over-pressurizing. **NOTE: If no bypass valve is installed, extra caution should be used in starting up a cold system; i.e. do everything slowly.**
4. Crack open the outlet (downstream) block valve.
5. Slowly open the inlet (upstream) block valve observing the outlet (downstream) pressure gauge. Determine if the regulator is flowing. If not, slowly rotate the regulator adjusting screw clockwise (CW) (viewed from above) until flow begins.
6. Continue to slowly open the inlet (upstream) block valve until fully open.

7. Continue to slowly open the outlet (downstream) block valve, especially when the downstream piping system isn't pressurized. If the outlet (downstream) pressure exceeds the desired pressure, close the block valve and go to Step 2, then return to Step 4.
8. When flow is established steady enough that the outlet (downstream) block valve is fully open, begin to slowly close the bypass valve, if installed. **NOTE: The needle valve (39) is shipped in a full open position. If the system is unstable due to pressure fluctuations, slowly close the needle valve (39) until the system becomes stable. This needle valve (39) should never be in a fully closed position.**
9. Develop system flow to a level near its expected normal rate, and reset the regulator setpoint by turning the adjusting screw CW (viewed from above) to increase outlet pressure, or CCW to reduce outlet pressure.
10. Reduce system flow to a minimum level and observe setpoint. Outlet pressure will rise from the setpoint of Step 9. The maximum rise in outlet pressure on decreasing flow should not exceed the stated upper limit of the range spring by greater than 10%; i.e. 10-40 psig (.69-2.8 Barg) range spring, at low flow the outlet pressure should not exceed 44 psig (3 Barg). If it does, consult factory.

SECTION V

V. SHUTDOWN

1. On systems with a bypass valve, and where system pressure is to be maintained as the regulator is shut down, slowly open the bypass valve while closing the inlet (upstream) block valve. Fully close the inlet (upstream) block valve. (When on bypass, the system pressure must be constantly observed and manually regulated.) Close the outlet (downstream) block valve.

 CAUTION
<p>Do not walk away and leave a bypassed regulator unattended!</p>

2. If the regulator and system are to both be shutdown, slowly close the inlet (upstream) block valve. Close the outlet (downstream) valve only if regulator removal is required.

SECTION VI

VI. MAINTENANCE



WARNING

SYSTEM UNDER PRESSURE. Prior to performing any maintenance, isolate the regulator from the system and relieve all pressure. Failure to do so could result in personal injury.

A. General:

1. Maintenance procedures hereinafter are based upon removal of the regulator unit from the pipeline where installed.
2. Owner should refer to owner's procedures for removal, handling, cleaning and disposal of non-reusable parts, i.e. gaskets, etc.
3. Refer to Figure 1 for standard regulator (**NOTE:** "LP" variation has larger diaphragm area than "HP" variation). Refer to Figures 2 through 4 for option blow-ups.

B. Diaphragm Replacement:

1. Using an overhead hoist, lift regulator on to a flat surface work bench.



WARNING

SPRING UNDER COMPRESSION. Prior to removing flange bolts, relieve spring compression by removing the adjusting screw. Failure to do so may result in flying parts that could cause personal injury.

2. Relax range spring (28) by turning adjusting screw (or T-bar) (32) CCW (viewed from above) until removed from spring chamber (13).
3. Draw or embed a match mark between diaphragm case (14) and spring chamber casting (13) along flanged area.
4. Remove all flange nuts (30) and bolts (29).
5. Remove spring chamber (13), spring button (27), and range spring (28).
6. Draw second match mark on diaphragm case (14) flange in alignment with a match mark on the threaded end of the stem (58) to indicate "free vertical movement" position of the plug (12) and stem (58).
7. Securing the "flats" on the threaded end of the stem (58) with adjustable wrench, remove pressure plate nut (24) by rotating CCW (viewed from above).

NOTE: Do not rotate the plug (12) and stem (58). The plug (12) and seat rings (10 & 11) have been mechanically lapped at the factory per ANSI Class II seat leakage and assembled to provide optimum "free vertical movement".

8. Pry loose pressure plate (22) from diaphragm(s) (20) and remove both. Inspect to ensure no deformation due to over-pressurization. If deformed, replace. **NOTES:** 1. Not removing the pusher plate (17) or rotating the plug (12) and stem (58) will provide performance equal to original factory performance when diaphragm(s) (20) is replaced with a like diaphragm(s) (20). Refer to Section VI.C, steps 13 and 14 for correct diaphragm setting if pusher plate (17) or stem lock nut (19) is removed, or valve plug assembly (12) is rotated. 2. Refer to quantity of diaphragm(s) (20) incorporated in the bill of materials listing. Depending on outlet pressure level, multiple metal diaphragms may be "stacked".
9. Remove diaphragm gasket (21) and pusher plate gasket (18). Clean gasket sealing surfaces thoroughly.
10. Install new diaphragm gasket (21) on diaphragm case (14) flange and new pusher plate gasket (18) on pusher plate, for metal diaphragms. For composition diaphragm, apply a 1/8" continuous bead of Dow/Corning RTV 732 (or equivalent) to the underside of the diaphragm pusher plate hole.
11. Position new diaphragm(s) (20) over threaded end of valve plug assembly (12).
12. Ensuring that the curved outer rim side of the pressure plate (22) rests against the diaphragm(s) (20) directly, place the pressure plate (22) over threaded end of the stem (58).
13. Install pressure plate nut (24) on threaded end of valve plug assembly (12) and tighten to a torque value of 75-80 Ft-lbs (101-108 Nm) for metal diaphragm, or 30-35 Ft-lbs (40-47 Nm) for composition diaphragm. Maintain alignment of match marks on the valve plug assembly (12) with second match mark on diaphragm case (14) flange. **NOTE:** Use two flange bolts (29) to keep multiple diaphragms' (20) bolt holes properly aligned while tightening pressure plate nut (24). DO NOT USE FINGERS TO HOLD DIAPHRAGMS (20) DURING TIGHTENING OF PRESSURE PLATE NUT (24).
14. Set range spring (28) on retainer hub of pressure plate (22).
15. Place multi-purpose, high temperature grease into depression of spring button (27) where adjusting screw (or T-bar) (32) bears. Set spring button (27) on to range spring (28); ensure spring button (27) is laying flat.
16. Aligning the match marks, place spring chamber (13) over the above stacked parts. Install all flange bolts (29) and flange nuts (30). Mechanically tighten bolting (29) (30) in a cross pattern that allows spring chamber (13) to be pulled down evenly. Recommended torque values are as follows:

Model	Diaphragm Material	Torque	Bolt Size
8310HP	ALL	45 ft-lbs (61 Nm)	5/8" Ø
8310LP	ALL	45 ft-lbs (61 Nm)	1/2" Ø

NOTE: Never replace bolting (29) (30) with just any bolting, if lost. Bolt heads and nuts are marked with specification identification markings. Use only proper grades as replacements.

17. Reinstall adjusting screw (or T-bar) (32) with lock nut (or lever) (33).
18. Spray liquid leak detector to test around bolting (29)(30), diaphragm case (14), and spring chamber (13) flanges for leakage. Ensure that an outlet pressure is maintained during this leak test of at least mid-range spring level; i.e. 10-40 psig (.69-2.8 Barg) range spring, 25 psig (1.7 Barg) test pressure minimum.

C. Trim Inspection:

1. To inspect the internal trim parts, refer to Section VI.A. and B.1 through 9 for diaphragm replacement and proceed as follows.
2. Secure the “flats” on the threaded end of the valve plug assembly (12) with adjustable wrench and remove pusher plate (17) and stem lock nut (19) by rotating CCW (viewed from above). **NOTE:** Do not rotate the valve plug assembly (12).
3. Draw or embed a match mark between body (1) and bottom flange (3).
4. Loosen and remove body stud nuts (8) CCW (viewed from bottom) to remove bottom flange (3). Inspect the bottom guide bushing (4) for excessive wear. If worn, both the guide bushing (4) and the bottom flange (3) must be replaced. **NOTE: DO NOT REMOVE BONNET (2).** The bonnet (2) acts as a guide to align the valve plug assembly (12) into the seat rings (10 and 11).
5. Firmly grasp end of the valve plug assembly (12) by hand and pull out of the body (1) cavity.
6. Inspect the seating surfaces of the plug (12.1) for nicks or excessive wear.
7. Using a flashlight or other light source, examine the interior of body (1) cavity. Also, inspect the seating surfaces of both the upper and lower seat rings (10 and 11) for excessive wear. If either the plug (12.1) or the seat rings (10 and 11) are worn and in need of replacement, contact the factory for authorization to return unit for repair. **NOTE: Overhaul and replacement of trim parts is not easily accomplished by non-factory trained personnel.**
8. For Composition seat replacement:
 - a. Secure flats on upper plug (12.1) in a soft jawed vise.
 - b. Rotate lower retainer (12.7) CCW to remove.
 - c. Inspect and replace lower seat disc (12.6). Apply Loctite 242 (or equivalent) to threads of lower retainer (12.7) and install lower retainer onto lower plug (12.3).

- d. Rotate lower plug (12.3) CCW to remove lower plug (12.3) and Belleville washers (12.2).
 - e. Remove upper retainer (12.5) and upper seat disc (12.4). Inspect upper seat disc (12.4) and replace.
 - f. Apply Loctite 242 (or equivalent) to threads of upper retainer (12.5) and install on upper seat disc (12.4). Install Belleville washers (12.2).
 - g. Apply Loctite 242 (or equivalent) to threads on lower plug (12.3) and install onto threaded end of upper plug (12.1).
 - h. Remove from vise.
9. Remove the lower body gasket (6) and clean sealing surface thoroughly.
 10. Install valve plug assembly (12) into body (1) and place new body gasket (6) onto body (1).
 11. Align match mark and replace bottom flange (3) on body (1). Reinstall flange stud nuts (8). Mechanically tighten nuts (8) in alternating cross pattern that allows bottom flange (3) to be pulled up evenly. Recommended torques values are as follows:

Regulator Size	Torque	Bolt Size
1-1/2" - 2" (DN32-50)	50 Ft-lbs (68 Nm)	1/2"
3" - 4" (DN80-100)	100 Ft-lbs (136 Nm)	5/8"

12. Fully thread stem lock nut (19) and pusher plate (17) on end of valve plug assembly (12). Refer to Figure 1 for correct orientation of the pusher plate (17).
13. Calibrate diaphragm (20) setting and correct valve plug assembly (12) travel as follows:
 - a) Lift and hold valve plug assembly (12) up tight against the seats (10 and 11).
 - b) Adjust the pusher plate (17) so that the gasket surface face of the pusher plate (17) is flush with the top of the diaphragm case (14) flange.
 - c) Draw the stem lock nut (17) up tight against the pusher plate (17) by holding “flats” milled on pusher plate (17).
14. Grasp threaded end of valve plug assembly (12) by hand and ensure that the assembly moves freely by lifting the valve plug assembly (12) in and out of the seats (10 and 11), making sure it does not “stick”. If it does not move freely, rotate valve plug assembly (12) CW until new position is found which allows optimum “free vertical movement” in and out of seats.
15. Proceed with diaphragm (20) assembly instructions in accordance with Section IV.B., steps 10 through 18. **NOTE: Do not rotate valve plug assembly (12) from optimum “free vertical movement” position during final assembly.**

SECTION VII

VII. TROUBLE SHOOTING GUIDE

1. Erratic operation; chattering.

Possible Causes	Remedies
A. Oversized regulator; inadequate rangeability.	A1. Check actual flow conditions, re-size regulator for minimum and maximum flow. A2. Decrease regulator pressure drop; decrease inlet pressure by placing a throttling orifice in inlet piping union; 2-stage pressure drop by using with another regulator in series. A3. Install next step higher range spring. Contact factory. A4. Before replacing regulator, contact factory.
B. Worn plug/stem assembly; inadequate guiding.	B1. Contact factory.

2. Leakage through the spring chamber vent hole.

Possible Causes	Remedies
A. Normal-life diaphragm failure.	A. Replace diaphragm.
B. Abnormal short-life diaphragm failure.	B1. Can be caused by excessive chattering. See No. 1. to remedy chatter. B2. Can be caused by corrosive action. Consider alternate diaphragm material. B3. For composition diaphragms, assure not subjecting to over-temperature conditions. B4. Downstream (outlet) pressure buildup occurring that overstresses diaphragms. Relocate regulator or protect with safety relief valve.

3. Downstream pressure will not reach desired setting.

Possible Causes	Remedies
A. Regulator undersized.	A1. Confirm by opening bypass valve together with regulator. A2. Check actual flow conditions, re-size regulator; if regulator has inadequate capacity, replace with larger unit.
B. Incorrect range spring (screwing in CW of adjusting screw does not allow bringing pressure level up to proper level).	B. Replace range spring with proper higher range. Contact factory.
C. Too much droop.	C1. Review droop expected. C2. Contact factory.
D. Restricted diaphragm movement.	D. Ensure no moisture in spring chamber at temperatures below freeze point. Ensure no dust or debris entering vent opening. If rainwater or debris can enter, re-orient spring chamber.

4. Excessive pressure downstream.

Possible Causes	Remedies
A. Regulator not closing tightly.	A. Inspect trim and plug alignment.
B. Downstream block.	B. Check system; isolate (block) flow at regulator inlet - not outlet. Relocate regulator if necessary.
C. No pressure relief protection.	C. Install safety relief valve, or rupture disc.
D. Restricted diaphragm movement.	D. Ensure no moisture in spring chamber at temperatures below freeze point. Ensure no dust or debris entering vent opening. If rainwater or debris can enter, re-orient spring chamber.

5. Sluggish operation.

Possible Causes	Remedies
A. Plugged spring chamber vent.	A. Clean vent opening.
B. Fluid too viscous.	B. Heat fluid. Contact factory.

SECTION VIII

VIII. ORDERING INFORMATION NEW REPLACEMENT UNIT vs PARTS "KIT" FOR FIELD REPAIR

To obtain a quotation or place an order, please retrieve the Serial Number and Product Code that was stamped on the metal name plate and attached to the unit. This information can also be found on the Bill of Material ("BOM"), a parts list that was provided when unit was originally shipped. (Serial Number typically 6 digits). Product Code typical format as follows: (last digit is alpha character that reflects revision level for the product).

□□□□ - □□□□ 7 - □□□□□□□□□□

NEW REPLACEMENT UNIT:

Contact your local Cashco, Inc., Sales Representative with the Serial Number and Product code. With this information they can provide a quotation for a new unit including a complete description, price and availability.

PARTS "KIT" for FIELD REPAIR:

Contact your local Cashco, Inc., Sales Representative with the Serial Number and Product code. Identify the parts and the quantity required to repair the unit from the "BOM" sheet that was provided when unit was originally shipped.



CAUTION

Do not attempt to alter the original construction of any unit without assistance and approval from the factory. All purposed changes will require a new name plate with appropriate ratings and new product code to accommodate the recommended part(s) changes.

NOTE: *Those part numbers that have a quantity indicated under "Spare Parts" in column "A" reflect minimum parts required for inspection and rebuild, - "Soft Goods Kit". Those in column "B" include minimum trim replacement parts needed plus those "Soft Goods" parts from column "A".*

If the "BOM" is not available, refer to the cross-sectional drawings included in this manual for part identification and selection.

A Local Sales Representative will provide quotation for appropriate Kit Number, Price and Availability.

The contents of this publication are presented for informational purposes only, and while every effort has been made to ensure their accuracy, they are not to be construed as warranties or guarantees, express or implied, regarding the products or services described herein or their use or applicability. We reserve the right to modify or improve the designs or specifications of such product at any time without notice. Cashco, Inc. does not assume responsibility for the selection, use or maintenance of any product. Responsibility for proper selection, use and maintenance of any Cashco, Inc. product remains solely with the purchaser.

Item No.	Description	Repair Kit A
1	Body	
2	Bonnet	
3	Bottom Flange	
4	Guide Bushing	
5	Stem Bushing	
6	Body Gasket	‡
7	Body Stud	
8	Body Stud Nut	
10	Upper Seat Ring	
11	Lower Seat Ring	
12	Plug Assembly	
12.1	Upper Plug	
12.2	Belleville Washer	
12.3	Lower Plug	
* 12.4	Upper Seat Disc	‡
* 12.5	Upper Retainer	
* 12.6	Lower Seat Disc	‡
* 12.7	Lower Retainer	
13	Spring Chamber	
14	Diaphragm Case	
15	O-ring	‡
16	Bonnet Nut	
17	Pusher Plate	
18	Pusher Plate Gasket	‡
19	Stem Lock Nut	
20	Diaphragm(s)	‡
21	Diaphragm Gasket	‡
22	Pressure Plate	
23	Diaphragm Support Plate	
24	Pressure Plate Nut	
25	Diaphragm Ring	
27	Spring Button	
28	Range Spring	
29	Flange Bolt	
30	Flange Nut	
32	Adjusting Screw (or Handwheel Assy)	
33	Adjusting Screw Lock nut (or Lever)	
34	Seal Washer	
35	Closing Cap	
36	Closing Cap Gasket	
37	Bleeder Valve	
38	Pipe Nipple	
39	Needle Valve	
40	Spring	
41	Diaphragm Case Nut	
42	Flush Bushing	
43	Pipe Plug	
51	Pipe Nipple	
57	Rotational Stop	
58	Stem	
Not Shown:		
44	Pipe Nipple	
45	Elbow	
54	Drive Screw	
55	Flow Arrow	

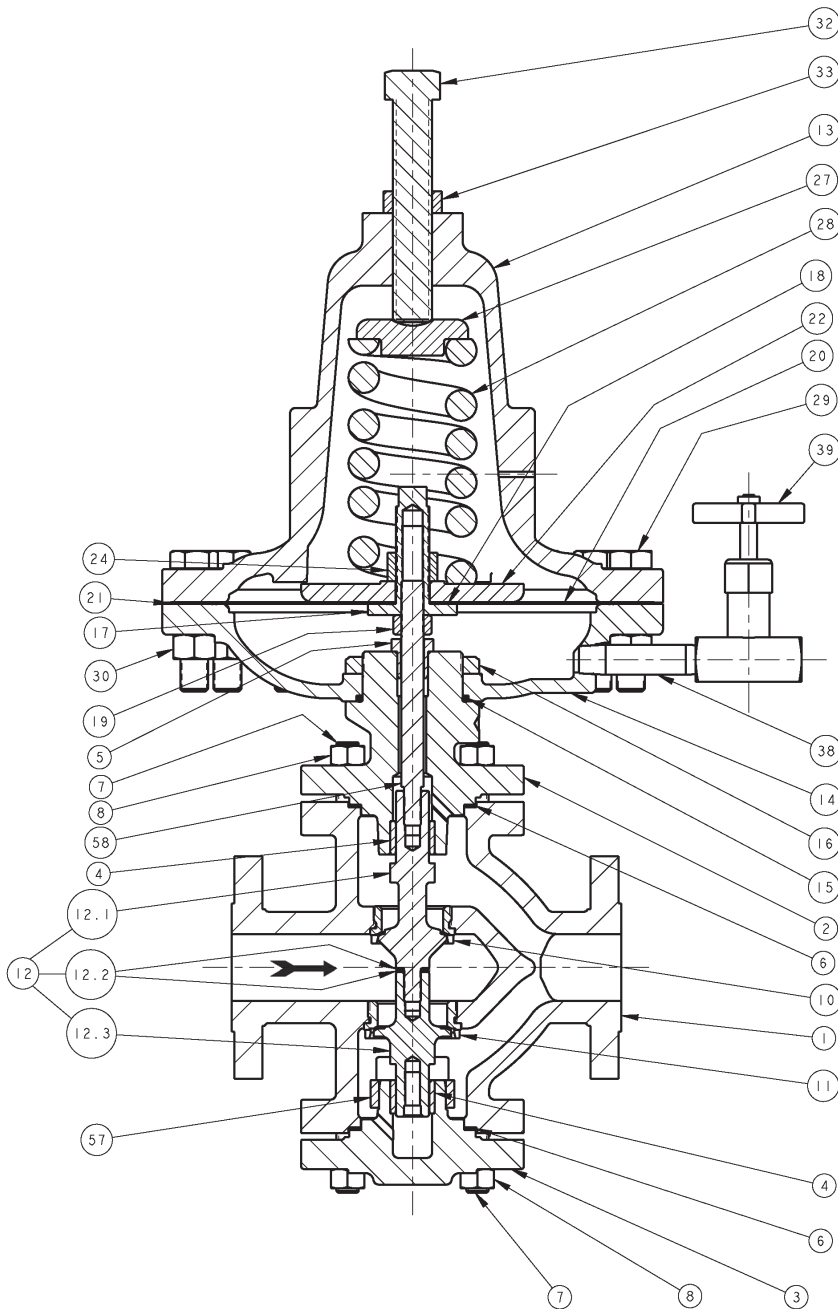
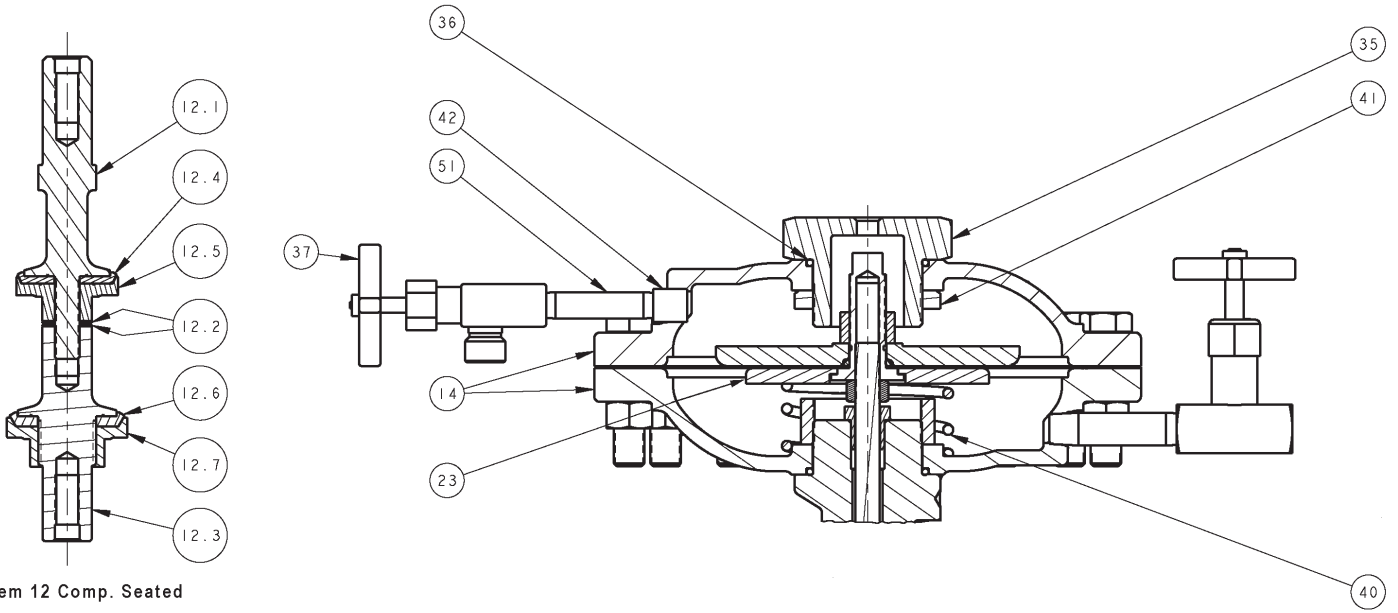

Figure 1: Standard Model 8310HP/LP
(NOTE: Variation "LP" has a larger diaphragm area than the "HP".)

* Comp. Seat Plug Assembly Only



Item 12 Comp. Seated
Plug Assembly

Figure 2: Model 8310HP only – Option -20, Dome Loaded

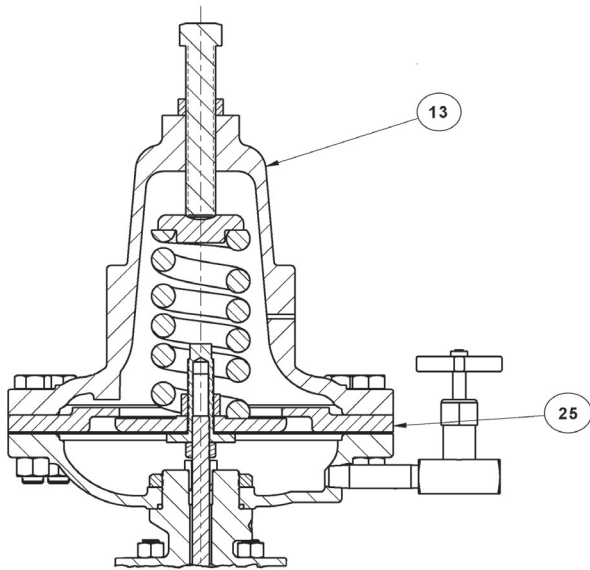

Figure 3: Model 8310HP only – Option -80, High Pressure Spring Chamber Construction

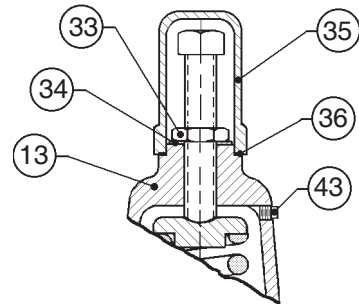

Figure 4: Model 8310HP/LP, Option-1 Closing Cap



IOM ADDENDUM:

ATEX DIRECTIVE 2014/34/EU and THE EQUIPMENT AND PROTECTIVE SYSTEMS INTENDED FOR USE IN POTENTIALLY EXPLOSIVE ATMOSPHERES REGULATIONS 2016

Cashco, Inc. declares that the products listed in the table below has been found to comply with the Essential Health and Safety Requirements relating to the design and construction of products intended for use in potentially explosive atmospheres given in Annex II of the ATEX Directive 2014/34/EU and given in Schedule 1 of The Equipment and Protective Systems Indented for Use in Potentially Explosive Atmospheres Regulations 2016. Compliance with the Essential Health and Safety Requirements has been assured by compliance with EN ISO 80079-36:2016 and EN ISO 80079-37:2016. The product will be marked as follows:



The 'X' placed after the technical file number indicates that the product is subject to specific conditions of use as follows:

1. The maximum surface temperature depends entirely on the operating conditions and not the equipment itself. The combination of the maximum ambient and the maximum process medium temperature shall be used to determine the maximum surface temperature and corresponding temperature classification, considering the safety margins described prescribed in EN ISO 80079-36:2016, Clause 8.2. Additionally, the system designer and users must take precautions to prevent rapid system pressurization which may raise the surface temperature of system components and tubing due to adiabatic compression of the system gas. Furthermore, the Joule-Thomson effect may cause process gases to rise in temperature as they expand going through a regulator. This could raise the external surface temperature of the regulator body and the downstream piping creating a potential source of ignition. Whether the Joule-Thomson effect leads to heating or cooling of the process gas depends on the process gas and the inlet and outlet pressures. The system designer is responsible for determining whether the process gas temperature may raise under any operating conditions.
2. Where the process medium is a liquid or semi-solid material with a surface resistance in excess of $1G\Omega$, special precautions shall be taken to ensure the process does not generate electrostatic discharge.
3. Special consideration shall be made regarding the filtration of the process medium if there is a potential for the process medium to contain solid particles. Where particles are present, the process flow shall be $<1\text{m/s}$ ($<3.3\text{ ft/s}$) in order to prevent friction between the process medium and internal surfaces.
4. Effective earthing (grounding) of the product shall be ensured during installation.
5. The valve body/housing shall be regularly cleaned to prevent build up of dust deposits.
6. Regulators must be ordered with the non-relieving option (instead of the self-relieving option) if the process gas they are to be used with is hazardous (flammable, toxic, etc.). The self-relieving option vents process gas through the regulator cap directly into the atmosphere while the non-relieving option does not. Using regulators with the self-relieving option in a flammable gas system could create an explosive atmosphere in the vicinity of the regulator.
7. Tied diaphragm regulators with outlet ranges greater than 7 barg (100 psig) should be preset to minimize the risk that improper operation might lead to an outboard leak and a potentially explosive atmosphere.
8. All equipment must only be fitted with manufacturer's original spare parts.
9. Ensure that only non-sparking tools are used, as per EN 1127-1, Annex A.

	PRODUCT
REGULATORS	31-B, 31-N
	1164, 1164(OPT-45)
	1171, 1171(OPT-45), 1171(CRYO)
	2171, 2171(OPT-45), 2171(CRYO), 3171
	1465, 3381, 3381(OPT-45), 3381(OPT-40)
	4381, 4381(OPT-37), 4381(CRYO), 4381(OPT-45), 5381
	MPRV-H, MPRV-L
	PBE, PBE-L, PBE-H
	CA-1, CA-2
	CA1, SA1, CA4, SA4, CA5, SA5
	DA2, DA4, DA5, DA6, DA8
	DA0, DA1, DAP, SAP
	SLR-1, SLR-2, PTR-1
	ALR-1, ULR-1, PGR-1
	BQ, BQ(OPT-45), BQ(CRYO)
	123, 123(CRYO), 123(OPT-45), 123(OPT-46G)
	123-1+6, 123-1+6(OPT-45), 123-1+6(OPT-46G), 123-1+6+S, 123-1+6+S(OPT-40)
	1000HP, 1000HP(OPT-37), 1000HP(OPT-45), 1000HP(OPT-45G), 1000HP(CRYO)
	1000HP-1+6, 1000HP-1+8, 1000LP, 1000LP(OPT-45), 1000LP(OPT-46G)
	6987
	8310HP, 8310HP-1+6, 8310HP-1+8, 8310LP, 8311HP, 8311LP
	345, 345(OPT-45)
	BA1/BL1, PA1/PL1
	C-BPV, C-PRV, C-CS
	D, D(CRYO), D(OPT-37), D(OPT-20), D(OPT-45)
	DL, DL(LCC), DL(OPT-45)
	BR, BR(CRYO)
	HP, HP(LCC), HP(OPT-45), HP(OPT46G), HP-1+6+S(OPT-40), HP-1+6+S
	P1, P2, P3, P4, P5, P7
	B2, B7
	POSR-1, POSR-2
	5200P, 5300P
135	
NW-PL, NW-SO	
CG-PILOT	
FG1	
CONTROL VALVES	RANGER, 987, PREMIER
	964, 521, 988, 988-MB, 989
	2296/2296HF
	SCV-30, SCV-S
TANK BLANKETING	8700, 8910, 8920, 8930, 8940
	2100, 2199
	3100, 3200, 3300, 3400, 3500, 3600, 3700
	1078, 1088, 1100, 1049
	5100, 5200, 5400, 5500
	4100, 4200, 4300, 4400, 4500, 4600
MISC	764P/PD, 764-37, 764T

Cashco, Inc.
P.O. Box 6
Ellsworth, KS 67439-0006
PH (785) 472-4461
Fax. # (785) 472-3539
www.cashco.com
email: sales@cashco.com

Cashco GmbH
Handwerkerstrasse 15
15366 Hoppegarten, Germany
PH +49 3342 30968 0
Fax. No. +49 3342 30968 29
www.cashco.com
email: germany@cashco.com

Cashco do Brasil, Ltda.
Al.Venus, 340
Indaiatuba - Sao Paulo, Brazil
PH +55 11 99677 7177
Fax. No.
www.cashco.com
email: brazil@cashco.com

Printed in U.S.A. IOM-8310HP/LP-Basic