



ISO Registered Company

MODEL 1000HP - DIFFERENTIAL PRESSURE REDUCING REGULATOR

SECTION I

I. DESCRIPTION AND SCOPE

The Model 1000HP-1+6 and 1000HP-1+8 are differential pressure reducing regulators used to control differential pressure between downstream (outlet or P_2) pressure and a loading (P_{Load}) pressure to the spring chamber. Sizes are 1/2" , 3/4", 1", 1-1/4", 1-1/2" and 2" (DN15, 20, 25, 32, 40 and 50). With proper trim utilization and jet selection, this unit is suitable for liquid, gaseous, or steam service. Refer to Technical Bulletin 1000HP-DIFF-TB for sizing, application and selection recommendations.

SECTION II

II. INSTALLATION

1. An inlet block valve should always be installed. An outlet block valve is desirable.
2. A manual bypass valve is recommended for "hot piping" systems to assist in piping warm-up at startup.
3. An isolation valve on the loading line is not recommended. The annular body ring of the 1000HP-1+8 may be piped to a safe drainage point, but no valve should be installed in the drain line.
4. Pipe unions must be installed to allow removal from piping. Trim can only be changed by unit removal from pipeline. If flanges are utilized, a lap joint flange is required on the inlet end of the regulator to help align bolt holes as the cylinder screws into place. **NOTE:** Cashco does not recommend field welding on the cylinder (inlet) end of the valve due to the possibility of warpage.

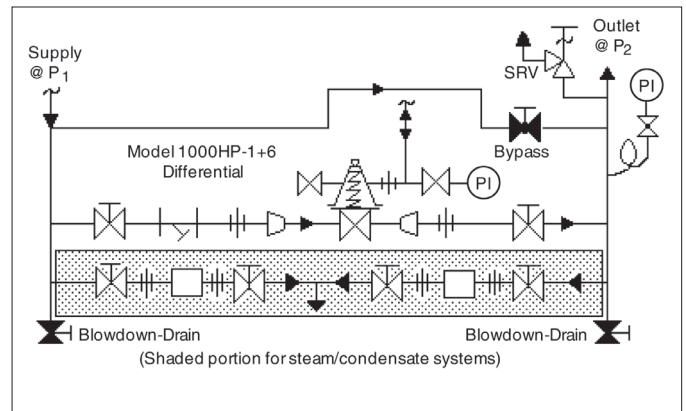

Recommended Piping Schematic for Differential Pressure Reducing Station

5. An outlet pressure gauge should be located approximately ten pipe diameters downstream, and within sight. A loading pressure (or differential pressure) gauge is recommended.
6. All installations should include a downstream relief device if the inlet pressure could exceed the pressure rating of any downstream equipment or the maximum outlet pressure rating of the unit.
7. Clean the piping of all foreign material including chips, welding scale, oil, grease and dirt before installing the regulator. Strainers are recommended.
8. In placing thread sealant on pipe ends prior to engagement, ensure that excess material is removed and not allowed to enter the regulator upon startup.
9. Flow Direction: Install so the flow direction matches the arrow cast on the body.

CAUTION

DO NOT HYDROSTATIC TEST THROUGH AN INSTALLED UNIT; ISOLATE FROM TEST. DO NOT HYDROSTATIC TEST THE LOADING PRESSURE WITHOUT PRESSURE IN THE MAIN REGULATOR.

The nameplate indicated outlet pressure rating, if reached, may cause internal damage. Refer to Technical Bulletin Model 1000HP-DIFF-TB, Table 3 for "emergency overpressure level" that will not do irreparable internal damage. In addition, note on the nameplate that the Inlet and Outlet pressure and temperature ratings are at different levels.

10. For best performance, install in well drained horizontal pipe, properly trapped if a steam service application.
11. Differential Regulator – (Refer to Dwg. Opt-1+6 for single diaphragm or Dwg. Opt-1+8 for double

diaphragm design): Regulator may be rotated around the pipe axis 360° and may be installed in a horizontal or vertical pipeline.

12. Regulators are not to be direct buried underground.

SECTION III

III. PRINCIPLE OF OPERATION

1. The differential Model 1000HP is also available in two options: 1000HP-1+6 is single diaphragm construction; 1000HP-1+8 is double diaphragm construction. The double diaphragm construction prevents the loading fluid from direct mixing with the system fluid in case of diaphragm failure.
2. Movement occurs as pressure variations register on the diaphragm. One pressure is the outlet (P_2) or downstream pressure, which registers on the “underneath” side of the diaphragm. The second pressure registered is the loading (P_{Load}) pressure in the spring chamber “above” the diaphragm. The range spring determines the differential pressure level (P_{Set}). As outlet (P_2) pressure drops, the range spring pushes the diaphragm down, opening the port; as outlet (P_2) pressure increases, the diaphragm pushes up and the port closes. As the loading (P_{Load}) pressure varies, the outlet (P_2) pressure tends to follow. An increase in P_{Load} (ΔP_{Load}) will increase outlet P_2 pressure by nearly an equal amount ($\Delta P_{Load} = \Delta P_2$); a decrease in P_{Load} will have a similar effect on outlet P_2 pressure.
3. The Model 1000 includes a rocker arm in its operation mechanism. The rocker arm allows the regulator to operate flow-to-open (FTO), rather than conventional flow-to-close (FTC), which increases rangeability.
4. Due to the FTO design, there is a limit as to how low of a downstream (P_2 or outlet) pressure level setting is capable for a given inlet P_1 pressure. This is a function of the ratio of the port area to the diaphragm area. It is possible for there to be too high of an inlet pressure for the regulator to close off against. (Refer to 1000HP-DIFF-TB, Tables 9, 10, 11 and 12 for limits.) Reduced port, Opt-12, allows lower downstream (P_2 or outlet) pressure settings for a given upstream (P_1 or inlet) pressure level.

5. The Model 1000 includes an aspiration jet effect, due to the clearance of the piston from the body near the outlet. These clearances vary as to whether the fluid is a gas (including steam), a liquid, or a viscous liquid (required Opt-27). Jets must be selected to match one of these three general fluids. An improper jet will reduce performance.

NOTE: The regulator requires minimum output pressure level or the regulator will not close.

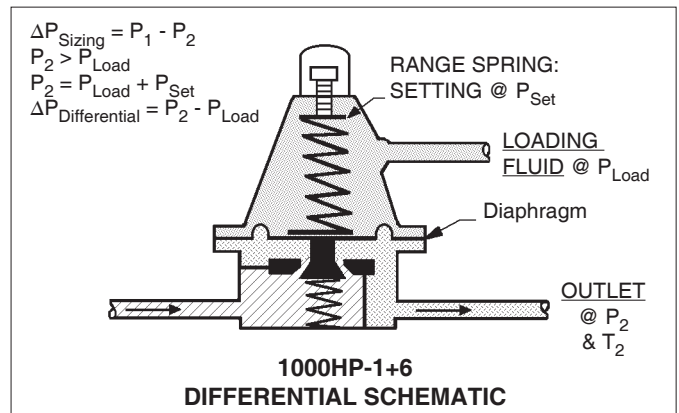

6. For a 1000HP-1+6 (single diaphragm) design, a complete diaphragm failure will cause the fluids to mix in the spring chamber or loading pressure piping system.
7. For a 1000HP-1+8 (double diaphragm) design, a complete diaphragm failure will cause the regulator to fail open, leaking fluid through the annular ring vent hole.

NOTE: Composition (soft) diaphragms may be utilized only on -1+6 single diaphragm construction.

8. For viscous fluids normally heated (heavy fuel oil), it may be desirable to include a flow-through spring chamber, the -65 Option.

SECTION IV

IV. STARTUP

1. Start with the block valves closed. A bypass valve may be used to maintain outlet pressure in the downstream system without changing the following steps.
2. Remove closing cap and relax the range spring by turning the adjusting screw counterclockwise (CCW) a minimum of three (3) full revolutions. This reduces the outlet (downstream) pressure set point.
3. If it is a “hot” piping system, and equipped with a bypass valve, slowly open the bypass valve to pre-heat the system piping and to allow slow expansion of the piping. Ensure proper steam trap operation if installed. Closely monitor outlet (downstream) pressure, via gauge, to ensure not over-pressurizing. **NOTE:** *If no bypass valve is installed, extra caution should be used in starting up a cold system; i.e. do everything slowly.*
4. Crack open the outlet (downstream) block valve.
5. Slowly open the inlet (upstream) block valve observing the outlet (downstream) pressure gauge. Determine if the regulator is flowing. If not, slowly rotate the regulator adjusting screw clockwise (CW) until flow begins.
6. Continue to slowly open the inlet (upstream) block valve until fully open.
7. Continue to slowly open the outlet (downstream) block valve, especially when the downstream piping system isn't pressurized. If the outlet (downstream) pressure exceeds the desired pressure, close the block valve and go to Step 2, then return to Step 4.
8. When flow is established steady enough that the outlet (downstream) block valve is fully open, begin to slowly close the bypass valve if installed.
9. Set the regulator set point (P_{set}) by turning the adjusting screw clockwise (CW) to increase outlet pressure or CCW to reduce outlet pressure. The outlet (P_2) pressure under these conditions will approximate the desired differential pressure when loaded with P_{Load} .
10. Pressurize the source of loading (P_{Load}) pressure and allow to fill the spring chamber cavity. Slightly open the bleeder valve to vent any air as the spring chamber is filling.
11. Develop system flow and pressure and readjust setpoint as required to obtain desired response. Performance should be analyzed at minimum and maximum flow levels.
12. Install closing cap.



CAUTION

Do not walk away and leave a bypassed regulator unattended!

SECTION V

V. SHUTDOWN



CAUTION

Loading Pressure must be shut off before shutting down the system pressure.

1. To prevent force imbalances and possible diaphragm failure, the loading pressure (P_{Load}) should always be shutdown first from its source of pressure. Systems sequencing must ensure this occurs.
2. It is recommended that manual operation not be attempted by a bypass valve during a shutdown.
3. When the loading pressure (P_{Load}) has been shutdown, the regulator outlet pressure (P_2) should decrease substantially. When this is observed, the inlet (upstream) block valve may be closed.

SECTION VI

VI. MAINTENANCE



WARNING

SYSTEM UNDER PRESSURE. Prior to performing any maintenance, isolate the regulator from the system and relieve all pressure. Failure to do so could result in personal injury.

A. General:

1. Maintenance procedures hereinafter are based upon removal of the unit from the pipeline where installed.
2. Owner should refer to owner's procedures for removal, handling and cleaning of reusable parts, and disposal of non-reusable parts, i.e. gaskets.
3. If desired, the gaskets may be lubricated with a light oil provided it is compatible with the fluid.

B. Diaphragm Replacement:

1. Securely install the body (1) in a vice with the spring chamber (2) directed upwards.



WARNING

SPRING UNDER COMPRESSION. Prior to removing flange bolts, relieve spring compression by backing out the adjusting screw. Failure to do so may result in flying parts that could cause personal injury.

2. Remove closing cap (31). Relax range spring (27) by turning adjusting screw (6) CCW until removed from spring chamber (2).
3. Paint or embed a match mark between body casting (1), spring chamber casting (2), and body spacer (42) along flanged area.
4. Remove all diaphragm flange nuts (9) and bolts (8). Remove nameplate (28).
5. Remove spring chamber (2), spring button (4) and range spring (27).
6. Pry up the diaphragm(s) (20) and diaphragm gasket (19) around the perimeter of the spring chamber (2) flange to ensure the diaphragm(s) (20) are not "sticking". (Diaphragm gasket

(19) is not used with a composition (soft) diaphragm.)

NOTE: The text hereafter will refer to:

- a. The -1+8 double diaphragm optional construction (-1+6 single diaphragm construction is similar. Text regarding composition diaphragm(s) (20) applies only to -1+6 option). Text portions dealing with body spacer (42), diaphragm spacer (41) and separation of total diaphragm (20) quantity into two "stacks" applies only to -1+8 option.
 - b. The "pusher plate and stud" (13) as a single part for 1/2" – 1-1/4" sizes and as two separate parts, a "pusher plate" (5) and a "pusher stud" (13), for 1-1/2" and 2" sizes.
7. Pry up the diaphragm(s) (20) and diaphragm gasket (19) around the perimeter of the body (1) diaphragm flange to ensure the diaphragm(s) (20) are not "sticking". (Diaphragm gasket (19) is not used with a composition (soft) diaphragm.)

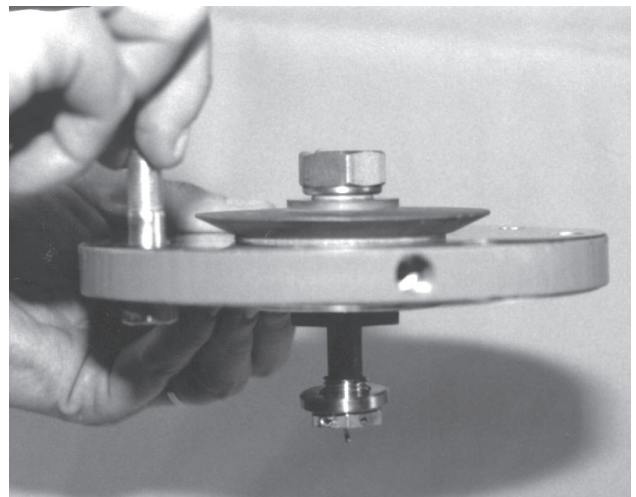

8. Remove diaphragm subassembly by sliding the pusher plate and stud (13), body spacer (42) and nut (11) in the direction of the regulator inlet, approximately 1/2"–3/4" (15-20 mm). The pusher plate and stud (13), stud nut (10), and stud collar (16) should disengage with the rocker arm (14) slot. Lift vertically for diaphragm subassembly removal, carefully holding the assembly at its outer edge to prevent the body spacer (42) from falling from between the diaphragm(s) (20).

9. Place the pusher plate stud (13) in a separate vise, gripping the stud (13) on the hexagonal cast-in-place edges located on the underneath side of the pusher plate stud. **NOTE: Do not remove the stud nut (10), stud collar (16), and the location locking cotter pin (15).**
10. Loosen and remove nut (11).
11. Lift and remove pressure plate (3) and O-ring (50).
12. Remove upper diaphragm(s) (20), diaphragm spacer (41) and body spacer (42).
13. Pry loose pusher plate and stud (13) from lower diaphragm(s) (20) or from lower pusher plate gasket (12). (Pusher plate gasket (12) is not utilized with composition (soft) diaphragm.) Remove the diaphragm(s) (20).
14. Remove pusher plate gasket (12) from pusher plate and stud (13).
15. Clean gasket sealing surfaces of pusher plate and stud (13), spring chamber (2), body (1), and pressure plate (3) thoroughly.
16. Install new pusher plate gasket (12) over pusher plate and stud (13).
17. Install one-half of total quantity of new diaphragm(s) (20) over pusher plate and stud (13). **NOTE: Refer to quantity of diaphragms (20) incorporated in the bill of materials listing. Depending on outlet pressure level, various quantities of metal diaphragms will be "stacked". They should always be in multiples of two for -1+8 option.**
18. Place diaphragm spacer (41) over pusher plate and stud. Place body spacer (42) over outer perimeter of diaphragm(s) (20).
19. Install remaining quantity of diaphragm(s) (20) over pusher plate and stud (13).
20. Place O-ring (50) over pusher plate and stud (13).
21. Inspect pressure plate (3) to ensure no deformation due to over-pressurization. If deformed, bent, or otherwise distorted, replace.
22. Ensuring that the curved outer rim side of the pressure plate (3) is down, place the pressure

plate (3) over the pusher plate and stud (13). Place nut (11) onto the stud (13) and tighten. Recommended torques are as follows:

Body Size	Metal Diaphragm	Comp. Diaphragm
3/8" – 1/2"	45–50 ft. lbs.	25–30 ft. lbs.
3/4" – 1"	45–50 ft. lbs.	30–45 ft. lbs.
1-1/4" – 2"	80–90 ft. lbs.	50–60 ft. lbs.

Use two flange bolts (8) to keep multiple diaphragms' (20) bolt holes properly aligned while tightening the nut (11).

⚠ CAUTION

Do not use your fingers to hold diaphragms (20) during tightening of nut (11)!

23. Remove cotter pin (15) securing stud nut (10) to lower end of pusher plate and stud (13), and replace with a new pin (15). (Do not allow the stud nut (10) to move when the cotter pin (15) is removed.)
24. Remove rocker arm shaft (17) and rocker arm (14). Measure inside of rocker arm (14) "prongs" as indicated in the following diagram. If either of the below dimensions are exceeded by 1/8" (3mm), replace rocker arm (14).

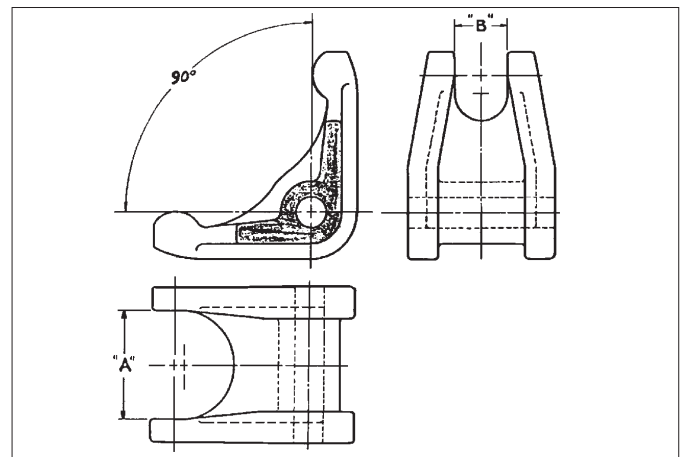

Valve Size							
DIM	MAT'L	1/2"	(DN15)	3/4"	(DN20)	1"	(DN25)
A	BRZ	7/8"	22 mm	1-5/32"	29 mm	1-7/16"	37 mm
B	BRZ	5/8"	16 mm	25/32"	20 mm	3/4"	20 mm
A	SST	13/16"	21 mm	1-1/16"	27 mm	1-7/16"	37 mm
B	SST	9/16"	14 mm	23/32"	18 mm	3/4"	20 mm
DIM	MAT'L	1-1/4"	(DN32)	1-1/2"	(DN40)	2"	(DN 50)
A	BRZ	1-13/16"	46 mm	1-25/32"	45 mm	2-3/16"	56 mm
B	BRZ	29/32"	23 mm	7/8"	22 mm	29/32"	23 mm
A	SST	1-1/2"	38 mm	1-25/32"	45 mm	2-5/32"	55 mm
B	SST	11/16"	17 mm	7/8"	22 mm	29/32"	23 mm

25. Check rocker arm shaft (17) for wear and straightness. Replace if damaged. Reinstall in body (1) through rocker arm (14). Apply thread sealant to the rocker arm shaft (17) threads prior to tightening. Make sure that the rocker arm shaft (17) enters the support slot opposite the threaded opening, and does not align crooked and restrained from full thread engagement of the rocker arm shaft (17). Make sure that the rocker arm (14) prongs that straddle the piston (24) hold the piston collar (23) against the piston (24); do not allow the rocker arm (14) prongs to push directly on the piston (24).

26. Install a new diaphragm gasket (19). Composition (soft) diaphragms require no diaphragm gasket. **NOTE: Use only gaskets manufactured by Cashco, Inc., that are of the same material as those originally supplied. Substitution may cause improper gasket compression.** It may also adversely change the diaphragm setting, which will affect the unit's performance, i.e. Option 1000-45, non-asbestos construction utilizes special gaskets.

27. Using small gauge wire approximately 18" (457 mm) long, form a hook and place the hook over one prong of the rocker arm (14), and rotate the rocker arm (14) up until slack is removed in the mechanism. Secure the wire through a body (1) flange bolt hole on the outlet side of the regulator.

28. Firmly holding the outer perimeter, take the diaphragm subassembly (Step 8) and lower it down into the body (1) cavity off-center approximately 3/4"-1" (20-25 mm) and towards the inlet side of the regulator. When fully lowered, slide the diaphragm subassembly horizontally towards the regulator outlet. The wire of Step 27. should hold the rocker (14) up to allow engaging of the pusher plate and stud (13) (with stud nut (10) and stud collar (16)), so the rocker arm (14) prongs rest directly on the stud collar. **NOTE: DO NOT ALLOW THE ROCKER ARM (14) PRONGS TO GET BETWEEN THE STUD NUT (10) AND THE STUD COLLAR (16).** Pull firmly to remove wire holding rocker arm (14) up.

29. Align diaphragm(s) (20) bolt holes with body (1) flange bolt holes. Install new diaphragm gasket (19) on top of diaphragm(s) (20). Visually center range spring (27) on to pressure plate (3), place spring button (4) on top of range spring (27).

30. Aligning the matchmarks, place spring chamber (2) over the above stacked parts. Install all bolts (8), nuts (9) and nameplate (28) by hand tightening. Tighten bolting (8 and 9) in a cross pattern that allows spring chamber (2) to be pulled down evenly. Recommended torques are as follows.

Body Size	Bolt Size	Metal Diaph ¹	Comp Diaph ²
1/2"	3/8"-24	25 ft-lb	25 ft-lb
3/4"	7/16"-20	30 ft-lb	30 ft-lb
1"-1-1/4"	1/2"-20	35 ft-lb	35 ft-lb
1-1/2"	9/16"-18	45 ft-lb	45 ft-lb
2"	5/8"-18	45 ft-lb	45 ft-lb

¹ Minimum recommended torque regardless of gasket materials. Some gasket materials may require higher bolt torques to obtain adequate seal.

² Gasket material may "set" with time; a recheck of torques should be made if the unit has been stored on the shelf for over 30 days.

NOTE: Never replace bolting (8 and 9) with just any bolting. Bolt heads and nuts are marked with specification identification markings. Use only proper grades as replacements.

31. Reinstall adjusting screw (6) with sealing locknut (7); install new closing cap gasket (32); install closing cap (31).

32. Pressurizing the body (1) and spring chamber (2) to the same level, soap solution test around bolting (8 and 9), body (1), spring chamber (2) flanges, closing cap (31) and cylinder (21) - to body (1) joint for leakage. Use 100 psig minimum inlet pressure to leak test. Actual service conditions should be used if in excess of the minimum condition. **NOTE: Do not pressurize spring chamber without equal or greater pressure in body registering on diaphragm(s) (20) underneath side.)**

C. Diaphragm Setting Adjustment:

1. In the previous "Sub-Section B., Diaphragm Replacement", care was taken to prevent removal of the stud collar (16) and stud nut (10). Location of the stud nut (10) is a critical adjustment for a Model 1000 regulator.

2. Not removing the stud nut (10) will provide performance equal to original factory performance when diaphragm(s) (20) is replaced with like diaphragm(s) (20); however, if the stud nut (10) is removed, or a switch is made from metal to composition (soft) diaphragm(s) (20), or vice versa, the diaphragm setting should be checked.

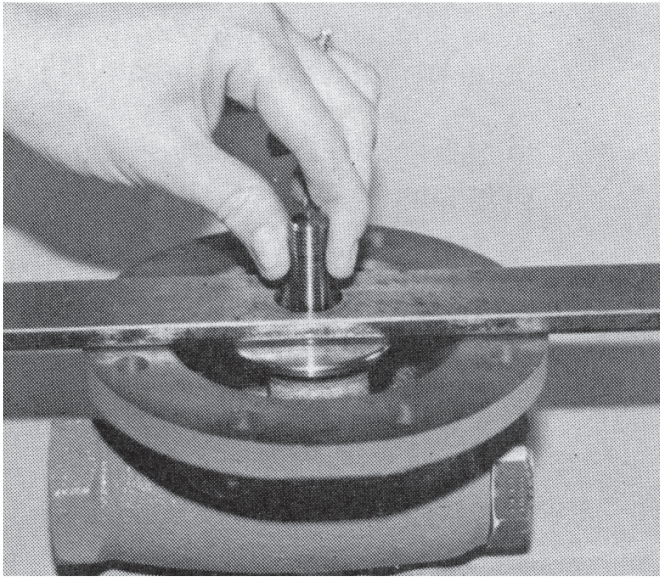

3. Follow procedure "Sub-Section B., Diaphragm Replacement" to the point of removing diaphragm(s) (20), Step 13. Remove diaphragm gasket (19) and pusher plate stud gasket (12). Obtain a flat 12" x 1-1/2" x 1/4" (15 mm x 40 mm x 6 mm) plate bar with a 3/4" (20 mm) hole drilled in the center. "Hook" the pusher plate stud (13) into the rocker arm (14) prongs properly. Pull firmly up on the pusher plate stud (13) to ensure that all slack is removed from the mechanism and that the piston (24) is seated firmly. Relax the pulling and place the flat bar over the pusher plate stud (13) with the stud (13) passing through the hole of the bar. Again, pull firmly up to remove mechanism slack. One of three positions will be reached:
 - a. Diaphragm setting too high. Pusher plate stud (13) will lift the flat bar over 0.020" (.51 mm).
 - b. Diaphragm setting acceptable. Bar lifted between 0.010"–0.020" (.25–.51 mm).
 - c. Diaphragm setting too low. Bar lifted less than 0.010" (.25 mm), or failed to be lifted.
4. The castle style stud nut (10) has six locations per revolution to align the stud nut (10) slots with the drilled hole through the pusher plate stud (13). Each stud nut (10) slot represents a movement up/down of 0.010" (.25 mm).

NOTE: The ideal diaphragm setting is 0.015" (.4 mm) high. Better performance is usually

obtained when the diaphragm is at this value, rather than a lower level. As the measuring of a thousandths of an inch is difficult with such a procedure, it is recommended that the "null" position be found where the diaphragm(s) (20) is flush with the body (1) flange (bar approximately at 0.000"). Remove the pusher plate stud (13), rotate the stud nut (10) one or two slots CCW to bring the setting to 0.010–0.020" (.25–.51 mm) high.

5. Place cotter pin (15) through the slot, bend over ends.
6. Continue reassembly per Sub-Section B, Diaphragm Replacement, Step 16.

E. Trim Removal and Replacement:

1. Install body (1) horizontally in a vise with the spring chamber (2) directed upwards, and the body (1) held at the outlet end.
2. Use a box end wrench, or socket, with a lever length of at least 24 inches (610 mm), and place over the hex surfaces of the cylinder (21). The wrench should be rapped with a hammer to loosen.
3. Continue to unscrew cylinder (21) until removed. The piston (24) and piston collar (23) should come out by gravity with the cylinder (21) removal.



CAUTION

Take precautions not to allow the piston (24) to fall from within the cylinder (21); tip cylinder with hex end down.

4. If an Option 1000-17 piston spring (30) is utilized, it also should be removed and replaced at trim replacement.
5. Inspect inside surface of cylinder (21) at four points:
 - a. Seat (21.2) ring. Check for erosion/wear on seating surfaces. If wear is excessive, consider utilizing Option 1000-15, stellited seat surface.
 - b. Seat (21.2). Check for wire drawing between cylinder (21.1) and seat (21.2) where pressed in. If wear exists here, an Option 1000-14, integral seat, should be utilized as a replacement.

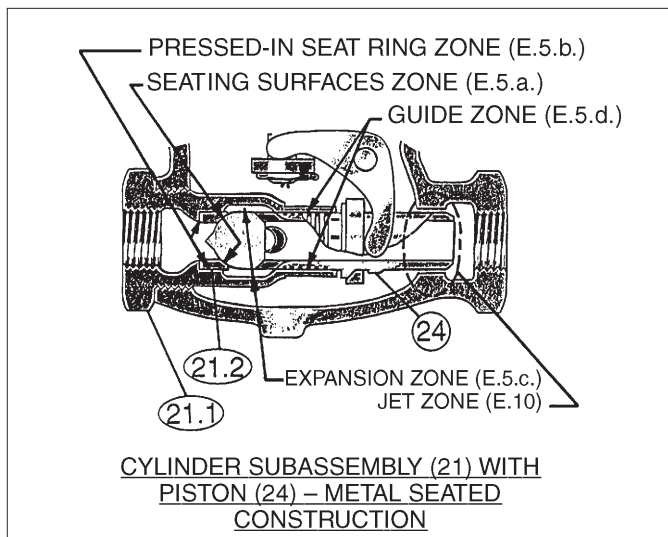

- c. Flow induced wear at expansion zone where fluid turns to enter the piston (24) center.
- d. Where the piston (24) ribbed guides bear (guide zone).

If wear is significant at any of these points, both cylinder subassembly (21) and piston subassembly (24 or 24, 25, and 26) should be replaced. (Cashco does not recommend attempting to replace the seat (21.2) by pressing out and then repressing in. Cashco also recommends that a cylinder (21) and piston (24 or 24, 25 and 26) be replaced as a set. Composition seat discs (25) may be replaced individually.

- 6. If a composition (soft) seat trim design is utilized, use the following sub-steps:
 - a. Tighten the “flats” of the seat disc screw (26) within a vise. Firmly hand-grip the piston (24) and turn CCW to loosen the seat disc screw (26). If too tight, place a screwdriver or similar rod within the piston (24) port holes and rotate. Remove the piston (24), and inspect for raised burrs around the port holes if a device is used to loosen; de-burr as required. NOTE: Do not grip the piston (24) with a wrench.
 - b. Remove the seat disc (25) and clean the recessed piston (24) area where the seat disc (25) is placed. If the edges which form the recess of the piston (24) are worn, also replace piston (24) and seat disc screw (26).

- c. Place seat disc (25) into recessed end of piston (24).
- d. Place thread sealant on threaded portion of seat disc screw (26), and manually rotate piston (24) into seat disc screw (26) (still fixed in vise) to secure seat disc (25). Tighten seat disc screw (26) firmly. Do not over-tighten to the point of embedding the seat disc screw (26) into the seat disc (25); the seat disc (25) should lay flat with no rounded surface. A mechanical aid is normally not required; hand tightening is normally sufficient.

- 7. Insert piston assembly (24 - metal seat) (24, 25 and 26 composition (soft) seat) into end of cylinder (21).
- 8. Place piston collar (23) over the end of piston (24), ensuring that the spherical surface of the piston (24) and the piston collar (23) bear against each other.
- 9. Clean the body (1) cavity through the openings. Clean the “jet area” just inside the body (1) outlet end through which the piston (24) projects. Clean all parts to be reused.
- 10. Use special care cleaning the flat mating surfaces of the body (1) and cylinder (21) shoulder, as this pressurized joint is metal-to-metal with no gasket. (See NOTE next step.)
- 11. Lubricate the cylinder (21) threads lightly with thread sealant. Insert the entire trim stack into the body (1) opening and screw until tightly seated. Using the hammer and wrench handle, impact the cylinder (21) into the body (1).

NOTES: 1. Take special precaution to keep piston collar from getting “cocked” at an angle when inserted.

2. On 2" brass bodies (1) with brass trim, a TFE body O-ring (43) is utilized to seal between the body (1) and the cylinder (21) subassembly. This O-ring is not indicated on drawings.

- 12. Inspect the body (1) outlet end to ensure that the piston (24) is located nearly concentric to the body (1) bore in the jet area with clearance. Under no condition should the piston (24) be touching the body (1). Use two pencils or similar shafts to place in inlet and outlet ends of regulator and alternately push on each end

of the piston (24) to ensure free movement. (Total movement is approximately 1/8" (3mm)).

13. Bench test unit for suitable operation and seat leakage. **NOTE:** *Regulators are not*

normally tight shutoff devices. Pressure must build above setpoint for best shutoff.

14. Soap solution test around cylinder (21)-to-body (1) connection for leakage. Test pressure should be a minimum of 100 psig at the inlet or actual service conditions if higher.

SECTION VII

VII. TROUBLE SHOOTING GUIDE

1. Erratic operation; chattering.

Possible Causes	Remedies
A. Oversized regulator; inadequate rangeability.	A1. Check actual flow conditions, resize regulator for minimum and maximum flow. A2. Increase flow rate. A3. Decrease regulator pressure drop; decrease inlet pressure by placing a throttling orifice in inlet piping union. A4. Replace full orifice with reduced orifice; i.e. new cylinder required.
B. Worn piston/cylinder; inadequate guiding.	B. Replace trim.
C. Flow induced instability.	C1. Get straight runs of piping (5 diameters upstream, 10 downstream) to and from regulator. C2. Ensure outlet velocity is not excessive; use pipe reducer close to regulator outlet. C3. Add next higher range spring. Contact factory. C4. If composition diaphragm, switch to metal diaphragm.
D. Improper (oversized) jet.	D. Replace existing piston with new piston with proper jet.
E. Plugged trim.	E. Remove trim and check for plugged holes in piston, or debris in guide zone or jet zone.
F. Unstable loading pressure.	F1. Stabilize loading pressure; i.e. pump, control valve, etc. F2. Air in loading piping. Vent spring chamber.

2. Regulator differential pressure too low.

Possible Causes	Remedies
A. Setpoint too low.	A. Turn adjusting screw down (CW) to increase setpoint.
B. Regulator undersized; outlet pressure (P_2) droops below loading pressure (P_{Load}).	B1. Confirm by opening bypass valve together with regulator. B2. Check actual flow conditions, resize regulator; if regulator has inadequate capacity, replace with larger unit.
C. Plugged inlet strainer.	C. Remove strainer screen and clean; consider leaving screen out.
D. Plugged trim.	D. Remove trim and check for plugged holes in piston, or debris in guide zone or jet zone.
E. Incorrect range spring (turning adjusting screw CW does not allow bringing pressure level up to proper level).	E. Replace range spring with proper higher range. Contact factory.
F. Too much proportional band (droop); outlet pressure (P_2) droops below loading pressure (P_{Load}).	F1. Review P.B. (droop) expected. (See 2.B1 above.) F2. Diaphragm setting too low; check setting and raise as required. F3. Consider composition diaphragm over metal. F4. Improper jet; make sure jet matches actual fluid.
G. Restricted diaphragm movement. (Pressure plate hitting downstops.)	G. Diaphragm setting too low; check and raise as required.

3. Leakage through the body spacer vent hole, or mixing of fluids.

Possible Causes	Remedies
A. Normal-life diaphragm failure.	A. Replace diaphragm.
B. Abnormal short-life diaphragm failure.	B1. Can be caused by excessive chattering. See No. 1. to remedy valve chatter. B2. Can be caused by corrosive action. Consider alternate diaphragm material. B3. For composition diaphragms, ensure not subjecting to over-temperature conditions. B4. Downstream (outlet) pressure buildup occurring that overstresses diaphragms. B5. Shutoff of valve inlet pressure while loading pressure is still on.
C. Pusher plate gasket or O-Ring leaking.	C. Replace gasket and O-ring.

4. Excessive pressure downstream.

Possible Causes	Remedies
A. Regulator not closing tightly.	<p>A1. Overly compressed range spring; i.e. approaching solid height. Use next higher range spring.</p> <p>A2. Inspect the seating. Clean and lap metal seat surfaces; replace if lapping does not remedy. If composition seats are depressed, nicked or embedded with debris, replace seat disk.</p> <p>A3. Diaphragm setting too high; check setting.</p> <p>A4. Inlet pressure too high for orifice size; check permissible inlet (P_1) pressure level for a given outlet. Change to reduced port if required.</p> <p>A5. Leakage past pressed in seat ring; consider integral seat.</p> <p>A6. When diaphragm subassembly was put into place, the rocker arm got between the stud collar and the stud nut rather than on top of the stud collar.</p>
B. Downstream block.	B. Check system; isolate (block) flow at regulator inlet, not outlet. Relocate regulator if necessary.
C. No pressure relief protection.	C. Install safety relief valve, or rupture disc.
D. Restricted diaphragm movement.	<p>D1. Diaphragm setting too high; check and lower as required.</p> <p>D2. Ensure no moisture in spacer ring at temperatures below freeze point. Ensure no dust or debris entering vent opening. If rainwater or debris can enter, reorient spring chamber. (Not possible on -1+6.)</p>

5. Sluggish operation.

Possible Causes	Remedies
A. Plugged piston or jet zone.	A. Remove trim and clean.
B. Fluid too viscous.	B. Heat fluid.
C. Improper (undersized) jet.	C. Replace existing piston with new piston for viscous service; i.e. Opt-27.

6. Frequent resetting of setpoint.

Possible Causes	Remedies
<p>A. Overpressurization downstream resulting in:</p> <ol style="list-style-type: none"> 1. Bent metal diaphragm(s) 2. Sprung rocker arm 3. Range spring overstressed/fatigued. 	<p>A1. Replace diaphragms. Correct potential source of downstream overpressure.</p> <p>A2. Check measurements of rocker arm. Replace if necessary.</p> <p>A3. Replace range spring; consider next higher range spring.</p>

7. Not able to maintain setpoint.

Possible Causes	Remedies
A. Diaphragm may be bent due to pressure reversal.	A. Make sure to prevent system reversal.

8. Excess leakage:

Possible Causes	Remedies
A. Faulty seating surfaces.	A1. Seat has been nicked by welding splatters. A2. Composition seat is damaged. A3. Composition seat driven into metal seat surface due to overpressure.
B. Outlet pressure setting too low for inlet pressure.	B. Refer to Technical Bulletin.

SECTION VIII

VIII. ORDERING INFORMATION

NEW REPLACEMENT UNIT vs PARTS "KIT" FOR FIELD REPAIR

To obtain a quotation or place an order, please retrieve the Serial Number and Product Code that was stamped on the metal name plate and attached to the unit. This information can also be found on the Bill of Material ("BOM"), a parts list that was provided when unit was originally shipped. (Serial Number typically 6 digits). Product Code typical format as follows: (last digit is alpha character that reflects revision level for the product).

□□□□ - □□□□ 7 - □□□□□□□□□□□□

NEW REPLACEMENT UNIT:

Contact your local Cashco, Inc., Sales Representative with the Serial Number and Product code. With this information they can provide a quotation for a new unit including a complete description, price and availability.



CAUTION

Do not attempt to alter the original construction of any unit without assistance and approval from the factory. All purposed changes will require a new name plate with appropriate ratings and new product code to accommodate the recommended part(s) changes.

PARTS "KIT" for FIELD REPAIR:

Contact your local Cashco, Inc., Sales Representative with the Serial Number and Product code. Identify the parts and the quantity required to repair the unit from the "BOM" sheet that was provided when unit was originally shipped.

NOTE: *Those part numbers that have a quantity indicated under "Spare Parts" in column "A" reflect minimum parts required for inspection and rebuild, - "Soft Goods Kit". Those in column "B" include minimum trim replacement parts needed plus those "Soft Goods" parts from column "A".*

If the "BOM" is not available, refer to the cross-sectional drawings included in this manual for part identification and selection.

A Local Sales Representative will provide quotation for appropriate Kit Number, Price and Availability.

The contents of this publication are presented for informational purposes only, and while every effort has been made to ensure their accuracy, they are not to be construed as warranties or guarantees, express or implied, regarding the products or services described herein or their use or applicability. We reserve the right to modify or improve the designs or specifications of such product at any time without notice. Cashco, Inc. does not assume responsibility for the selection, use or maintenance of any product. Responsibility for proper selection, use and maintenance of any Cashco, Inc. product remains solely with the purchaser.

MODEL 1000HP-1+6 DIFFERENTIAL PRESSURE REDUCING REGULATOR

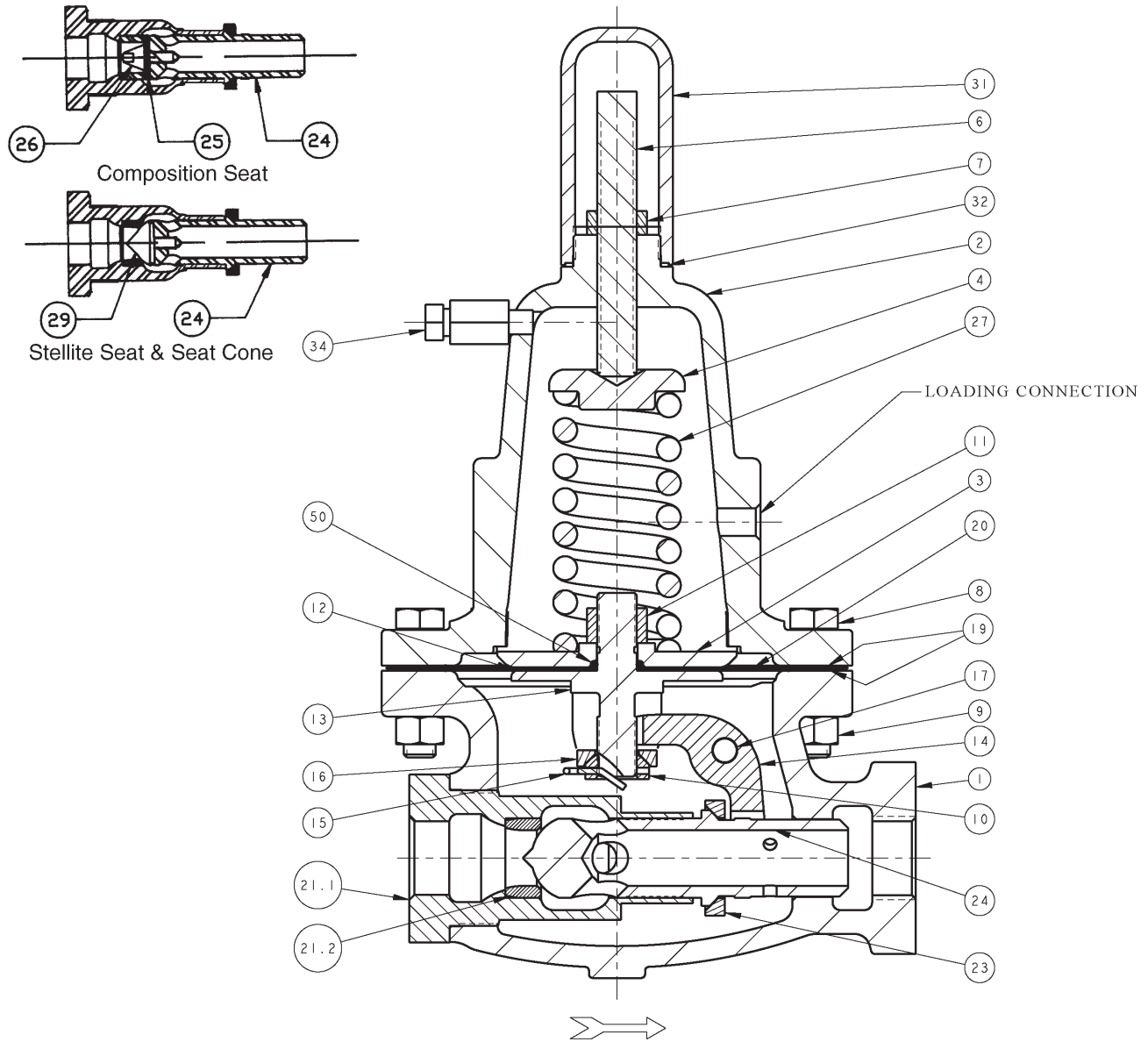

ITEM NO.	DESCRIPTION	REPAIR PARTS		ITEM NO.	DESCRIPTION	REPAIR PARTS		Items Not Shown	
		KIT A	KIT B			KIT A	KIT B		
1.	BODY & BODY ASSY			19.	DIAPHRAGM GASKET	*	**	5	Pusher Plate
2.	SPRING CHAMBER (or Loading Chamber)			20.	DIAPHRAGM(S)	*	**	18	Body Plug/Drain Tap
3.	PRESSURE PLATE			21.	CYLINDER ASSEMBLY		**	30	Piston Spring
4.	SPRING BUTTON			21.1	CYLINDER			33	Spring Chamber Pipe Plug
6.	ADJUSTING SCREW			21.2	VALVE SEAT			36	Identification Plate (Supplied upon request)
7.	ADJUSTING SCREW LOCK NUT	*	**	23.	PISTON COLLAR		**	43	Body O-ring
9.	FLANGE NUT			24.	PISTON		**		
10.	STUD NUT			25.	SEAT DISC	*	**		
11.	PRESSURE PLATE NUT	*	**	26.	SEAT DISC SCREW		**		
12.	PUSHER PLATE GASKET	*	**	27.	RANGE SPRING				
13.	PUSHER PLATE STUD			28.	NAME PLATE				
14.	ROCKER ARM			29.	SEAT CONE (-15 OPT)				
15.	COTTER PIN		**	31.	CLOSING CAP (-1 OPT)				
16.	STUD COLLAR			32.	CLOSING CAP GASKET (-1 OPT)	*	**		
17.	ROCKER ARM SHAFT			34.	BLEEDER VALVE ASSEMBLY				
				50.	O-RING	*	**		

MODEL 1000HP-1+8 DIFFERENTIAL PRESSURE REDUCING REGULATOR

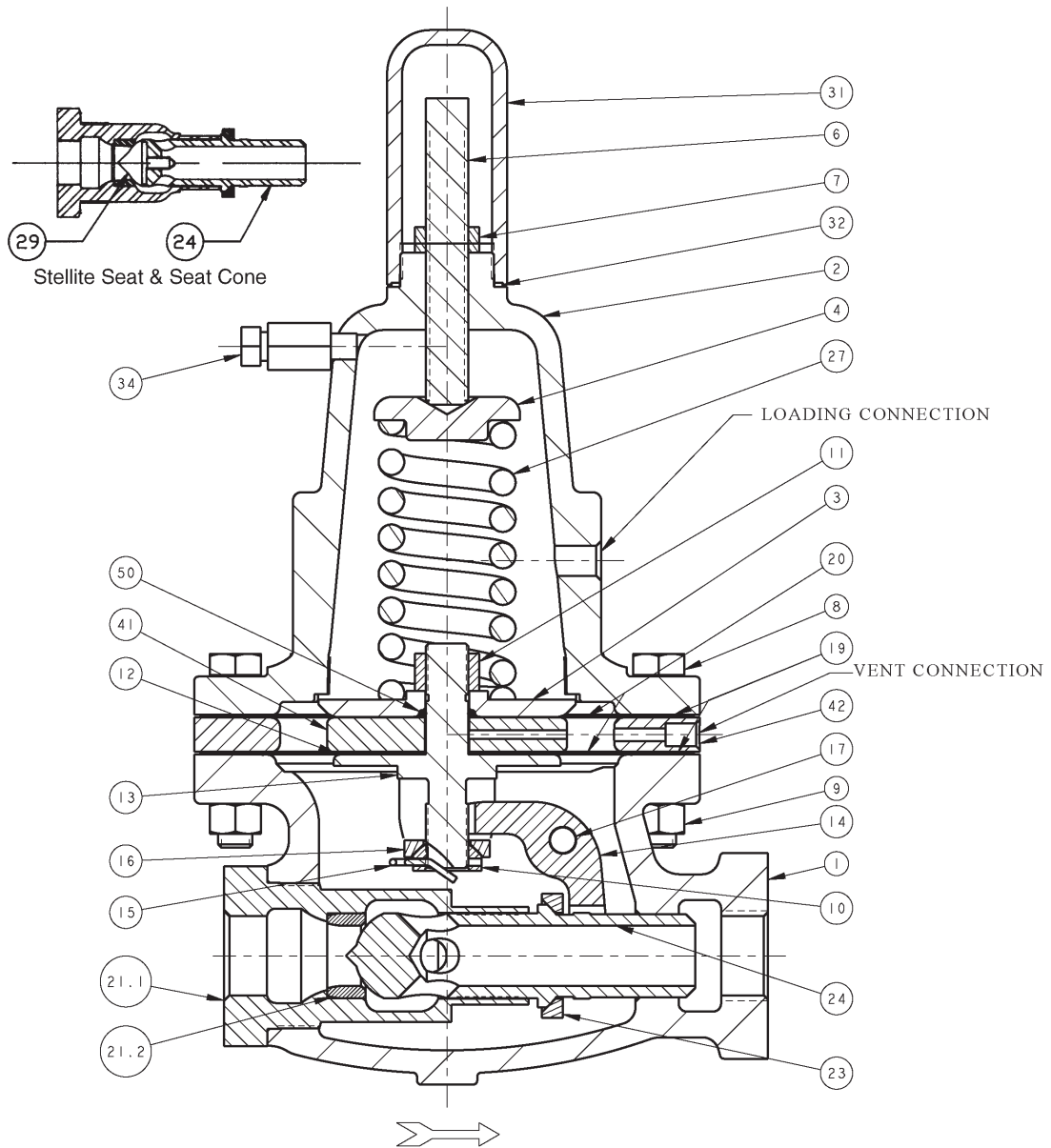

ITEM NO.	DESCRIPTION	REPAIR PARTS		ITEM NO.	DESCRIPTION	REPAIR PARTS		Items Not Shown	
		KIT A	KIT B			KIT A	KIT B		
1.	BODY & BODY ASSY			19.	DIAPHRAGM GASKET	*	**	5	Pusher Plate
2.	SPRING CHAMBER (or Loading Chamber)			20.	DIAPHRAGM(S)	*	**	18	Body Plug/Drain Tap
3.	PRESSURE PLATE			21.	CYLINDER ASSEMBLY		**	30	Piston Spring
4.	SPRING BUTTON			21.1	CYLINDER			33	Spring Chamber Pipe Plug
6.	ADJUSTING SCREW			21.2	VALVE SEAT			36	Identification Plate (Supplied upon request)
7.	ADJUSTING SCREW LOCK NUT	*	**	23.	PISTON COLLAR		**	43	Body O-ring
9.	FLANGE NUT			24.	PISTON		**		
10.	STUD NUT			27.	RANGE SPRING				
11.	PRESSURE PLATE NUT	*	**	28.	NAME PLATE				
12.	PUSHER PLATE GASKET	*	**	29.	SEAT CONE (-15 OPT)				
13.	PUSHER PLATE STUD			31.	CLOSING CAP (-1 OPT)				
14.	ROCKER ARM			32.	CLOSING CAP GASKET (-1 OPT)	*	**		
15.	COTTER PIN		**	34.	BLEEDER VALVE ASSEMBLY				
16.	STUD COLLAR			41.	DIAPHRAGM SPACER				
17.	ROCKER ARM SHAFT			42.	BODY SPACER				
				50.	O-RING	*	**		



IOM ADDENDUM:

ATEX DIRECTIVE 2014/34/EU and THE EQUIPMENT AND PROTECTIVE SYSTEMS INTENDED FOR USE IN POTENTIALLY EXPLOSIVE ATMOSPHERES REGULATIONS 2016

Cashco, Inc. declares that the products listed in the table below has been found to comply with the Essential Health and Safety Requirements relating to the design and construction of products intended for use in potentially explosive atmospheres given in Annex II of the ATEX Directive 2014/34/EU and given in Schedule 1 of The Equipment and Protective Systems Indented for Use in Potentially Explosive Atmospheres Regulations 2016. Compliance with the Essential Health and Safety Requirements has been assured by compliance with EN ISO 80079-36:2016 and EN ISO 80079-37:2016. The product will be marked as follows:



The 'X' placed after the technical file number indicates that the product is subject to specific conditions of use as follows:

1. The maximum surface temperature depends entirely on the operating conditions and not the equipment itself. The combination of the maximum ambient and the maximum process medium temperature shall be used to determine the maximum surface temperature and corresponding temperature classification, considering the safety margins described prescribed in EN ISO 80079-36:2016, Clause 8.2. Additionally, the system designer and users must take precautions to prevent rapid system pressurization which may raise the surface temperature of system components and tubing due to adiabatic compression of the system gas. Furthermore, the Joule-Thomson effect may cause process gases to rise in temperature as they expand going through a regulator. This could raise the external surface temperature of the regulator body and the downstream piping creating a potential source of ignition. Whether the Joule-Thomson effect leads to heating or cooling of the process gas depends on the process gas and the inlet and outlet pressures. The system designer is responsible for determining whether the process gas temperature may raise under any operating conditions.
2. Where the process medium is a liquid or semi-solid material with a surface resistance in excess of $1G\Omega$, special precautions shall be taken to ensure the process does not generate electrostatic discharge.
3. Special consideration shall be made regarding the filtration of the process medium if there is a potential for the process medium to contain solid particles. Where particles are present, the process flow shall be $<1\text{m/s}$ ($<3.3\text{ ft/s}$) in order to prevent friction between the process medium and internal surfaces.
4. Effective earthing (grounding) of the product shall be ensured during installation.
5. The valve body/housing shall be regularly cleaned to prevent build up of dust deposits.
6. Regulators must be ordered with the non-relieving option (instead of the self-relieving option) if the process gas they are to be used with is hazardous (flammable, toxic, etc.). The self-relieving option vents process gas through the regulator cap directly into the atmosphere while the non-relieving option does not. Using regulators with the self-relieving option in a flammable gas system could create an explosive atmosphere in the vicinity of the regulator.
7. Tied diaphragm regulators with outlet ranges greater than 7 barg (100 psig) should be preset to minimize the risk that improper operation might lead to an outboard leak and a potentially explosive atmosphere.
8. All equipment must only be fitted with manufacturer's original spare parts.
9. Ensure that only non-sparking tools are used, as per EN 1127-1, Annex A.

	PRODUCT
REGULATORS	31-B, 31-N
	1164, 1164(OPT-45)
	1171, 1171(OPT-45), 1171(CRYO)
	2171, 2171(OPT-45), 2171(CRYO), 3171
	1465, 3381, 3381(OPT-45), 3381(OPT-40)
	4381, 4381(OPT-37), 4381(CRYO), 4381(OPT-45), 5381
	MPRV-H, MPRV-L
	PBE, PBE-L, PBE-H
	CA-1, CA-2
	CA1, SA1, CA4, SA4, CA5, SA5
	DA2, DA4, DA5, DA6, DA8
	DA0, DA1, DAP, SAP
	SLR-1, SLR-2, PTR-1
	ALR-1, ULR-1, PGR-1
	BQ, BQ(OPT-45), BQ(CRYO)
	123, 123(CRYO), 123(OPT-45), 123(OPT-46G)
	123-1+6, 123-1+6(OPT-45), 123-1+6(OPT-46G), 123-1+6+S, 123-1+6+S(OPT-40)
	1000HP, 1000HP(OPT-37), 1000HP(OPT-45), 1000HP(OPT-45G), 1000HP(CRYO)
	1000HP-1+6, 1000HP-1+8, 1000LP, 1000LP(OPT-45), 1000LP(OPT-46G)
	6987
	8310HP, 8310HP-1+6, 8310HP-1+8, 8310LP, 8311HP, 8311LP
	345, 345(OPT-45)
	BA1/BL1, PA1/PL1
	C-BPV, C-PRV, C-CS
	D, D(CRYO), D(OPT-37), D(OPT-20), D(OPT-45)
	DL, DL(LCC), DL(OPT-45)
	BR, BR(CRYO)
	HP, HP(LCC), HP(OPT-45), HP(OPT46G), HP-1+6+S(OPT-40), HP-1+6+S
	P1, P2, P3, P4, P5, P7
	B2, B7
	POSR-1, POSR-2
	5200P, 5300P
135	
NW-PL, NW-SO	
CG-PILOT	
FG1	
CONTROL VALVES	RANGER, 987, PREMIER
	964, 521, 988, 988-MB, 989
	2296/2296HF
	SCV-30, SCV-S
TANK BLANKETING	8700, 8910, 8920, 8930, 8940
	2100, 2199
	3100, 3200, 3300, 3400, 3500, 3600, 3700
	1078, 1088, 1100, 1049
	5100, 5200, 5400, 5500
	4100, 4200, 4300, 4400, 4500, 4600
MISC	764P/PD, 764-37, 764T

Cashco, Inc.
P.O. Box 6
Ellsworth, KS 67439-0006
PH (785) 472-4461
Fax. # (785) 472-3539
www.cashco.com
email: sales@cashco.com
Printed in U.S.A. C-BPV-TB

Cashco GmbH
Handwerkerstrasse 15
15366 Hoppegarten, Germany
PH +49 3342 30968 0
Fax. No. +49 3342 30968 29
www.cashco.com
email: germany@cashco.com

Cashco do Brasil, Ltda.
Al.Venus, 340
Indaiatuba - Sao Paulo, Brazil
PH +55 11 99677 7177
Fax. No.
www.cashco.com
email: brazil@cashco.com