



Valve Concepts, Inc.
ISO Registered Company

Model 5100 Pilot Operated Pressure / Vacuum Relief Vent End-of-line

SECTION I

I. DESCRIPTION AND SCOPE

The maintenance of this Pilot Operated Vent Valve (POVV) should only be done by qualified valve technicians. It is important that the technician be familiar with the API and corporate standards, corporate safety policies, and the relief vent manufacturer requirements. When repair services are performed by an outside company, the company needs to be a Cashco factory authorized repair center which specializes in low pressure venting devices.

For information on repair centers in your area, please contact:

Valve Concepts, Inc.
%Cashco, Inc.
607 West 15th Street
Ellsworth, KS 67439-0006
(785) 472-4461 (Phone)
(785) 472-3539 (Fax)

SECTION II

II. VALVE DESIGN AND FUNCTION

The Model 5100 Pilot Operated Vents are used on liquid storage tanks and other process vessels or systems to prevent structural damage during the process of filling or emptying of a tank or for changes in atmospheric conditions. Excess pressure is vented to atmosphere.

Storage tanks are pressurized when liquid is pumped in, compressing the existing vapor or when increasing temperature causes increased evaporation or expansion of existing vapor. Conversely, a vacuum may be created when fluid is pumped out or as atmospheric temperature decreases. To prevent structural damage, vapor must be allowed to escape or enter the tank at a specified flow rate. The volume rate of venting is dependent on the tank size, displacement rate and the flash point of the fluid. See API Standard 2000 for procedures to determine venting requirements.

A pilot operated relief vent has two principal advantages over other relief vent designs:

1. Bubble tight shutoff up to 100% of set point.
2. Full open capacity for pressure relief is achieved within 10% above set point.

Thus the vent valve is capable of operating at pressures closer to the maximum allowable working pressure of the tank. Operating at higher pressures reduces evaporation and total venting volume, thereby reducing product loss and the cost of handling emissions.

Each application must be reviewed to ensure material compatibility with all metal and soft good components with the service conditions. The pallet assembly, wetted components and tubing are 316 SST. Diaphragm material is FKM, unless specified otherwise.

The pilot valve is factory set to comply with the specifications on the purchase order. The adjustable pressure range is a function of the installed spring and will be stamped on the metal nameplate. The set point pressure may be changed within the design parameters of the spring while installed on line or in a maintenance shop. See Section IX for setting and testing procedures.

This manual is intended to provide recommended procedures and practices for installation, operation and maintenance of the Model 5100 POVV. Although this manual cannot cover all possible contingencies, these guidelines will provide safe and reliable pilot valve performance.

SECTION III

III. SAFETY WARNINGS



WARNING

Warning: Before beginning any relief vent inspection or maintenance, carefully read and understand the information in this manual. If there are any questions concerning the information in this manual, please contact the factory before proceeding.

Tank or system protection is the primary function of the Pilot Operated Vent Valve (POVV). It must be selected to meet the total pressure flow requirements within the maximum allowable working pressure of the system on which it is installed. Consult API Standard 2000 for tank protection sizing procedures. Improperly specified relief vents may result in structural damage to the tank or system, and can cause severe personal injury or death.

In the event of a diaphragm failure, the Model 5100 will vent pressure to the atmosphere causing the pressure relief valve to fail in the OPEN position. The vent will now function like a weight loaded vent under this condition with a lower set point. Consult the factory for any questions related to this over-pressure condition.



CAUTION

DO NOT attempt to change pressure set point beyond the limit specified on the nameplate.

The 1/2" OD SST pilot valve sensing line must be kept open and unobstructed to ensure that the pilot "senses" the actual tank pressure. For applications where tank vapors may condense or polymerize in the sensing tubing or the pilot valve, a nitrogen purge may be required to prevent internal obstruction of the tube. Consult the factory for recommendations.



CAUTION

DO NOT attempt to remove the vent from the tank or process vessel without first bleeding all pressure from the system. ALTERNATIVE MEANS OF PRESSURE RELIEF MUST BE PROVIDED WHEN THE VENT IS OUT OF SERVICE.

After isolating the relief vent, bleed all pressure from both main and pilot valve before removing the Model 5100 POVV.

NOTE: Both the pilot valve and main valve are exposed to the process vapors. Observe all plant procedures and Material Safety Data Sheet recommendations before inspecting, adjusting or servicing any components.

The vent on the spring bonnet of the pilot must be clean and unobstructed for proper and safe operation of the valve.

SECTION IV

IV. SHIPPING, INSPECTION AND STORAGE

The POVV vent is carefully packaged to prevent damage or contamination during shipping. Inspect the equipment when it is received and report any damage to the carrier immediately. The POVV should be stored in a clean environment with all the protective flange covers in place to prevent intrusion of foreign materials. If there are indications of physical damage or internal contamination, the valve may need to be disassembled, cleaned and inspected prior to installation.

Lifting brackets may be provided on the main valve for lifting and handling. To avoid damage to the lower flange surface, rest the vent on a soft clean

gasket material until it is ready to be installed. **DO NOT** store the POVV directly on the ground.

Make sure that any loading weights that might have been shipped separately, to protect the vent during shipping, are accounted for and stored with the vent. These weights, when required, will need to be installed during installation.

SECTION V

V. INSTALLATION:

The Model 5100 POVV is a precision device that must be handled carefully to ensure seat tightness.

WARNING

The vent must be installed in a vertical position. The tank nozzle on which the vent is mounted should have the same nominal diameter as the venting device. It is recommended that the tank nozzle flange face be within 1 degree of horizontal for best performance of the venting device.

1. At installation, the POVV should be carefully lifted into position using the lifting lugs on the body. Use the case assembly (122,129) to help align the body directly over the tank nozzle. **DO NOT** use the pilot valve or pickup line to pull the POVV into position.
2. Aluminum body vents should be mated to flat-faced 125# ASME flanges. Mating flanges should be flat within 0.020" and clean; free of scratches, corrosion and tool marks. A full faced gasket is recommended.
3. Install the flange gasket on the nozzle face. Use either a full faced or ring gasket for raised face flanges. Ensure that the gasket material is suitable for the service. See Table 1 for gasket dimensions.

Table 1 Body Flange Gasket Dimensions					
CS, SST 150# ASME RF	O.D.	I.D.	B.C.	Hole	Qty
2"	4.12	2.38	--	--	--
3"	5.38	3.50	--	--	--
4"	6.88	4.50	--	--	--
6"	8.75	6.62	--	--	--
8"	11.00	8.62	--	--	--
10"	13.38	10.80	--	--	--
12"	16.12	12.80	--	--	--
Alum w/ 125# ASME FF					
2"	6.00	2.00	4.75	.75	4
3"	7.50	3.00	6.00	.75	4
4"	9.00	4.00	7.50	.75	8
6"	11.00	6.00	9.50	.88	8
8"	13.50	8.00	11.75	.88	8
10"	16.00	10.0	14.25	1.00	12
12"	19.00	12.00	17.00	1.00	12

4. Center the gasket within the bolt circle of the tank nozzle flange.

NOTE: At installation, the vent valve should be carefully lifted into position using the lifting brackets on the body.

CAUTION

The lifting brackets should only be used for lifting the vent valve into place and should NOT be used for any other purpose.

5. Lubricate all studs and nuts with an appropriate thread lubricant. If stainless steel studs and nuts are required, use an anti-seize lubricant such as moly-disulfide.
6. Remove flange protective covers and carefully set POVV down on top the gasket and face of the nozzle flange.

WARNING

Minimum clearance between tank roof and vacuum inlet port must be at least equal to the vents' nominal flange bore. Tank nozzle bore must be greater than or equal to vent inlet flange bore. Inlet piping loads must be supported by appropriate structural supports, NOT by the vent body.

7. Install lockwashers and nuts. Tighten nuts to half the recommended torque value using an alternating crossing pattern. See Table 2.

Table 2 Recommended Minimum Torque Values *				
Size	Qty Holes	Bolt (UNC)	Torque (lb-ft)	
			Raised Face	Flat Face
2"	4	5/8"-11	31	81
3"	4	5/8"-11	43	106
4"	8	5/8"-11	29	68
6"	8	3/4"-10	51	101
8"	8	3/4"-10	78	142
10"	12	7/8"-9	75	138
12"	12	7/8"-9	93	179

* Torque values are based on a gasket factor $m = 3.5$, Gasket factor $y = 4000$ psi, operating pressure = 30 psi

8. Make sure that the gasket is compressed evenly and the flanges are not distorted.

NOTE: Misalignment of flange faces will cause bending stresses at the flange and may damage flange joint. Refer to Addendum-A on pages 16 and 17.

9. Finish tightening nuts to the point that no additional rotation occurs.
10. If loading weights were shipped separate from the vent, install weights on vacuum pressure pallet. Ensure that all packing has been removed.

SECTION VI

VI. PILOT MAINTENANCE:

A. General:

1. Maintenance procedures herein after are based upon removal of the pilot/vent valve unit from the vessel/piping where installed.
2. Owner should refer to owner's procedures for removal, handling and cleaning of nonreusable parts; i.e. gaskets, suitable solvents, etc.
3. All indicated Item Numbers that are with respect to the Pilot Assembly will be in parenthesis and underscored; i.e. (29). All Item Numbers that are with respect to the Main Valve are not underscored; i.e. (109).

B. Separation from Main Valve and Disassembly:

1. Disconnect sense tube (140) from sense tube connectors (138) and (139). Remove the pilot valve assembly from the nipple (132) by rotating the pilot body (01) CCW.
2. Secure pilot body (01) in vise with 'sensing' port facing front. Disconnect tubing (34) from fittings (32), (33).
3. Paint or embed a set of match marks between upper case (22), spacer (13) and lower case (03) along flanged area. *Note the location of 1/8" NPT tap from elbow (33) in relation to body sensing port and straight connector (32).*

4. Rotate the closing cap (29) CCW for removal. Loosen the adjusting screw nut (27) two revolutions. Rotate Adjusting screw (28) CCW and remove.
5. Remove diaphragm case nuts (19), washers (25) and cap screws (26). Grasp spring bonnet (23) and lift up until diaphragm case (22) clears top of spring button (21). Set assembly aside.
6. Lift range spring (20) and spring button (21) up and set aside.
7. Insert a tool in the slot in the top of stud (18) to prevent stud rotation. Rotate nut (19) CCW to remove nut and spring guides (17).
8. Remove sense pressure ring (15), sense support plate (16), sense diaphragm (14) and diaphragm case spacer (13).
9. Remove top bolt gasket (07), and sense diaphragm spacer (12).
10. Remove boost support plate (11), boost diaphragm (10), boost diaphragm spacer (09) and another bolt gasket (07).

FOR Pilot with Pressure \geq 3.2 psig: remove boost pressure ring (36).

11. Rotate 7/16" hex head cap screws (04) CCW to remove. Lift up on lower diaphragm case (03) to remove lower case and body gasket (02). **NOTE** the alignment of the four bolt holes and the sense hole in case (03) with the holes in the body (01).
12. Grasp spindle stud (18) and lift upwards to extract the spindle assembly (06) from the



WARNING

SPRING UNDER COMPRESSION. Prior to removing flange bolts, relieve spring compression by backing out the adjusting screw. Failure to do so may result in flying parts that could cause personal injury.

body (01). Remove seal diaphragm (08) from spindle. With a pick type tool lift out seat o-ring (05).

13. Rotate jam nut (27) CCW two rotations and remove blowdown needle (28) from body (01). Replace with new O-ring (30).
14. Inspect parts and replace if parts show signs of wear. Clean parts with suitable cleaner.

C. Re-assembly:

1. Insert new seat o-ring (05) in the bottom of the spindle assembly. Place spindle assembly inside the body cavity, threaded end up. Slide a new seal diaphragm over threaded end of spindle and position it on top of the body. Align holes in seal diaphragm with holes in body.
2. Position new body gasket (02) on top of the seal diaphragm, align gasket holes. **DO NOT cover sensing hole in the body.**
3. Align holes in the lower diaphragm case (03) with body (01) and place the case on top of the gasket. **DO NOT cover sensing hole.** Use cap screws (04) to secure lower diaphragm case (03) to the body. (01). Tighten to 10-15 ft. lbs.
4. Slide one bolt gasket (07) and boost diaphragm spacer (09) over threaded end of spindle (18).
5. Place another bolt gasket (07), the boost diaphragm (10), support plate-boost (11), and on spindle stud (18). Align bolt holes for all parts.

FOR Pilot with Pressure \geq 3.2 psig: install boost pressure ring (36).

6. Install sense diaphragm spacer (12) and the last bolt gasket (07) on spindle stud (18).
7. Place the diaphragm case spacer (13) on top of the diaphragm (10), (or on top of the boost pressure ring (36)) and align match marks per previous B 3.

8. Install a new sense diaphragm (14) on spindle stud (18) and align the bolt holes with the boost diaphragm (10) and spacer (13).
9. Stack the sense support plate (16) and the spring guides (17) over end of spindle stud (18).
10. Install and tighten nut (19) to secure all parts. (Check alignment of bolt holes around the circumference.)
11. Position the range spring (20) and spring button (21) on the spring guides (17).
12. Place pressure ring (15) on top of diaphragm (14). Recheck alignment of bolt holes.
13. Lower the upper diaphragm case (22) / spring bonnet (23) assembly over the spring (20), allow to rest on the pressure ring (15). (Ensure alignment of match marks per previous B 3.)
14. Install diaphragm case screws (26), flat washers (25), and nuts (19) and tighten.
15. Apply a light coat of Bostik Never-Seez to threads of blowdown needle (28). Thread completely into body until the nut (27) contacts the body (01) and then back out two rotations. Rotate nut (27) CW to secure nut tight.
16. Reinstall adjusting screw (28) and jam nut (27) in top of spring bonnet (23). Install closing cap (29).
17. Refer to Section IX for Calibration and Testing.
18. Install pilot body assembly on nipple (132) tight with CW rotation. Ensure the sense tube connector (139) of the pilot valve assembly is directly above sensing tube connector (138) of the main valve assembly.
19. Reconnect tubing (34) to fittings (32), (33) and tubing (140) to fittings (138),(139).

SECTION VII

VII. VENT VALVE MAINTENANCE:

CAUTION

If the vent valve must be removed from the tank for any reason, make sure that all pressure has been released before the flange fasteners are loosened. Refer to your company procedures before venting the tank pressure and when handling toxic or otherwise hazardous materials. Observe all standard safety precautions as specified on Material Safety Data Sheets for the product(s) in the system while removing the valve and during the repair.

A. General:

1. The Model 5100 POVV does not require routine lubrication or adjustments. It should be checked periodically, at least twice a year, to confirm that the vent is functioning properly and that the set point is correct.
2. The pilot valve is designed to function in a fail-safe manner. The failure of a seal or a diaphragm will cause pressure to be vented to the atmosphere; the resulting loss in pressure will cause the main valve to open under rising pressure.
3. Periodic inspection for seat tightness should be done to ensure compliance with local air pollution control requirements. If the vent relieves to the atmosphere, this may be accomplished with a gas detector calibrated for the principle product in the system.
4. The vent valve will need to be removed from the tank for inspection of diaphragms, gaskets, and seals. When this is done, the vent must be handled carefully using the lifting brackets (135) on the body.
5. The main and pilot valve housings, bodies, pallet assemblies, and other components are exposed to the process vapor.

B. Disassembly:

1. Disconnect the tubing connections (pilot to main valve) (138, 139, 140) and remove the pilot by rotating the pilot body (01) assembly CCW from nipple (132).

Actuator Diaphragm Replacement:

- a. Paint or embed a set of match marks between upper case (129) and lower case (122) across the case flange edge.
- b. Loosen and remove nuts (131) and cap screws (130).
- c. Lift up and remove the upper case (129) assembly and set aside. Remove joint tape (142) and diaphragm (128). **NOTE: To continue with disassembly skip to Pressure Pallet Diaphragm Replacement below.**
- d. Replace with new parts (142 and 128). Position and align bolt holes in the circumference of the diaphragm with the holes in the lower case (122).
- e. Reposition upper case assy (129) on diaphragm (128). Align marks made in step (a.) above.
- f. Install cap screws (130) and nuts (131) and tighten.
- g. Install pilot body assembly on nipple (132) tight with CW rotation. Ensure that straight connector (139) of the pilot valve assembly is directly above sensing tube connector (138) of the main valve assembly.
- h. Reconnect tubing (140) to fittings (138),(139). Refer to Section IX for Calibration and Testing.

Pressure Pallet Diaphragm Replacement:

(Disassembly continues from c. above)

- a. Paint or embed a set of match marks between weatherhood (119) and body (100).
- b. Rotate jam nuts (126) CCW coming down to rest against top of jack screw (124). Rotate jack nuts (125) CCW coming down to rest against nuts (126).
- c. Rotate jack screw (124) CCW and remove from threaded end of pallet guides (111).
- d. Grasp the case assy (AA) (122) and lift straight up to remove (AA) and weatherhood assy (119) from pallet guides (111).



CAUTION

Do not grasp weatherhood around the bottom edge, it maybe sharp.

NOTE: Support plate (127) will also slide off pressure stem (103). (Continue on to step i. unless changing gasket (121)).

To Remove Adapter Gasket: steps (e - h).

e. Lay the (AA) and weatherhood assy on flat surface, bottom edge of weatherhood resting on flat surface. Grasp the top of the support plate weldment and lift up to remove.

f. Paint or embed a set of match marks between weatherhood (119) and lower actuator case assy (122).

g. Flip the weatherhood over so lower case (122) is resting on the flat surface. Loosen and remove adapter bolts (123). Set weatherhood (119) to the side and remove weatherhood plate (120). Remove and replace actuator case gasket (121).

h. Align bolt holes in weatherhood plate (120) and weatherhood (119) with lower actuator case assy (122) and install adapter bolts (123). Tighten securely.

i. Remove wire screen (118) from seat ring. Lift pressure stem/pallet (103/106) assembly straight up off the seat ring (101). Inspect seating surface of seat ring and pallet diaphragm (107).

j. Carefully secure pressure stem (103) in a vise with lock nut (110) up. Remove nut from pressure stem.

k. Remove diaphragm retainer plate (108), diaphragm (107), pallet (106) and stiffener plate (105).

l. Clean and inspect parts for wear, replace if worn. Re-install stiffener (105) and pallet (106). **NOTE:** Apply small amount of TFE paste around the center opening (top surface) of the pallet.

m. Place a new diaphragm (107) on the pallet (106). **NOTE:** Apply small amount of TFE paste around the center opening (top surface) of the diaphragm (107).

n. Install the diaphragm retainer plate (108) and lock nut (110), secure nut tight.

o. Remove pallet (106) assembly from vise.

To Remove Pressure Pallet Seat Ring:

NOTE: If vent has integral or pressed in seat rings, contact the factory.

Paint or embed a set of match marks between the seat ring and the inside of the body.

p. Rotate bolts (102) CCW and remove. Place a wrench on the milled flats of the pallet guides (111), rotate CCW to remove. Mark the locations of guides on the edge of the seat ring (101) for reference at re-assembly.

q. Lift up to remove seat ring (101) and joint tape (142.1). (There is no tape on integral or pressed in seat rings.) Inspect guides (111) and inside cavity of the body (100) for any corrosion or product build up. Clean all parts as necessary. Seat surfaces must be clean and smooth for diaphragm and pallet to seal properly.

r. Install new joint tape (. See Figure 4. Align match marks for seat ring (101) with body, place seat ring back in body, resting on joint tape. Re-install pallet guides (111) around the seat ring as previously marked. Install bolts (102). Tighten bolts (102) and guides to 15 ft. lbs. (20.3 Nm).

s. Position bug screen (118) on top surface of seat ring (101). Position stem/pallet (103/106) assembly on seat ring (101).

t. Lift the lower actuator case assembly (AA) (122) with attached weatherhood (119) up and place it over the pallet guides (111). Align match marks between weatherhood and body, as per previous step a. Lower the weatherhood down on pallet guides (111).

u. Insert small end of support plate weldment (127) down through the hole in the center of the lower case (122) until it slides over the top of the pressure stem (103).

v. Install jack screw (124) on threaded end of pallet guides and tighten securely. Rotate jack nut (125) CW in equal increments until they rest tight against lower case (122). Rotate jam nut (126) CW to secure tight to jack nut (125).

w. Install new piece of joint tape and diaphragm (142 and 128). Position and align bolt holes in the circumference of the diaphragm with the holes in the lower case (122).

x. Reposition upper case assy (129) on diaphragm (128). Align match marks made in step B. 1. a. previous. Install cap screws (130) and nuts (131) and tighten.

y. Install pilot body assembly on nipple (132) tight with CW rotation. Ensure the sense tube connector (139) of the pilot valve assembly is directly above sensing tube connector (138) of the main valve assembly.

z. Reconnect tubing (140) to fittings (138) and (139).

d. Place stem (104) in a vise with the pallet end up. Remove lock nut (110). Lift up to remove diaphragm retainer plate (109), diaphragm (107), vacuum pallet (106) and stiffener plate (105).

e. Clean and inspect parts for wear, replace if worn.

f. Re-install stiffener (105) and pallet (106). **NOTE:** Apply small amount of TFE paste around the center opening (top surface) of the pallet. Install diaphragm (107) and diaphragm retainer plate (109). Re-install and tighten lock nut (110) on stem.

To Remove Vacuum Pallet Seat Ring:

NOTE: If vent has integral or pressed in seat ring, contact the factory.

g. Paint or embed a set of match marks between the seat ring and the inside of the body.

h. Rotate bolts (102) CCW and remove. Remove guides (112). (Use the slot on top of guides and rotate CCW.) Mark the location of these items on the seat ring (101) for reference at re-assembly.

i. Lift up to remove seat ring (101) and joint tape (142.1). (There is no joint tape on integral or pressed in seat rings.) Inspect guides (112) and inside of the body cavity (100) for any corrosion or product build up. Clean as necessary. Replace joint tape. See Figure 4.

j. Align match marks for seat ring (101) with body and place seat ring back in body, resting on joint tape. Re-install pallet guides (112) around the seat ring as previously marked. Install bolts (102). Tighten bolts (102) and guides to 15 ft. lbs. (20.3 Nm).

k. Position stem/pallet(103/106) assembly on seat ring (101). Carefully place loading weights on the pallet.

l. Place joint tape (142.0) in groove in body. Align match mark between cover and body, as per previous step a. above. Place the cover on the body. Install cover bolts (115) tight.



CAUTION

DO NOT change vacuum pressure ratings by removing from or adding weights to the pallet assembly without consulting the factory or your VCI representative.

Vacuum Pallet Diaphragm Replacement:

a. Paint or embed a set of match marks between the vacuum cover (114) and the body (100).

b. Rotate cover bolts (115) CCW and remove cover assembly (114), (116), (117). Inspect cover for corrosion, damage or product build up. Clean with a suitable solvent.

c. Lift upwards to remove vacuum stem/pallet (104/106) assembly, including any loading weights (113) that may be resting on the pallet(106). Inspect and clean seat ring (101). Check seat surface for any nicks, corrosion, pitting or product build-up. Seat surface must be clean and smooth for vent to preform properly.

NOTE: When installing the cover (114) ensure the vacuum stem (104) is inserted in the stem guide in the cover (114).

To Remove Inlet Screen:

- a. Rotate bolts CCW and remove bolts and retainer. Inspect and clean screen and reinstall to body (100).

SECTION VIII

**VIII. ORDERING INFORMATION
NEW REPLACEMENT UNIT vs PARTS "KIT" FOR FIELD REPAIR**

To obtain a quotation or place an order, please retrieve the Serial Number and Product Code that was stamped on the metal name plate and attached to the unit. This information can also be found on the Bill of Material ("BOM"), a parts list that was provided when unit was originally shipped. (Serial Number typically 6 digits).

NEW REPLACEMENT UNIT:

Contact your local Cashco, Inc., Sales Representative with the Serial Number and Product code. With this information they can provide a quotation for a new unit including a complete description, price and availability.

PARTS "KIT" for FIELD REPAIR:

Contact your local Cashco, Inc., Sales Representative with the Serial Number and Product code. Identify the parts and the quantity required to repair the unit from the "BOM" sheet that was provided when unit was originally shipped. If the "BOM" is not available, refer to the cross-sectional drawings included in this manual for part identification and selection.

A Local Sales Representative will provide quotation for appropriate Kit Number, Price and Availability.

 CAUTION
<p>Do not attempt to alter the original construction of any unit without assistance and approval from the factory. All purposed changes will require a new name plate with appropriate ratings and new product code to accommodate the recommended part(s) changes.</p>

The contents of this publication are presented for informational purposes only, and while every effort has been made to ensure their accuracy, they are not to be construed as warranties or guarantees, express or implied, regarding the products or services described herein or their use or applicability. We reserve the right to modify or improve the designs or specifications of such product at any time without notice. Cashco, Inc. does not assume responsibility for the selection, use or maintenance of any product. Responsibility for proper selection, use and maintenance of any Cashco, Inc. product remains solely with the purchaser.

SECTION IX

IX. PRESSURE CALIBRATION AND TESTING PROCEDURE FOR PILOT:

1. To determine set pressure, slowly increase the pilot inlet pressure. Simulated actuator pressure will rise with inlet. As set pressure is approached, the actuator pressure will begin to decrease. Continue to increase the inlet pressure slowly until the actuator pressure is 90% (+/- 10%) of the inlet pressure. This is the set pressure.
2. Rotate the set pressure adjusting screw (28) CW to increase set pressure or CCW to decrease set pressure. Continue to rotate the adjusting screw and repeat the test per Step 1 previous until the specified set pressure is achieved.
3. To determine reseal pressure, slowly decrease the inlet pressure and the actuator pressure will begin to increase. Reseat occurs when the actuator pressure equal the inlet pressure.
4. The difference between set and reseal pressure, "blowdown", can be adjusted with the blowdown needle (28). Maximum clockwise rotation provides rapid relief valve opening, "snap action" and maximum blowdown. Standard blowdown, unless otherwise specified is 7 - 10% below set pressure.
5. Increased counter clockwise rotation of blowdown screw provides "modulating" action and minimum (zero) blowdown. Reseat pressure is the same as set pressure.

NOTE: The blowdown needle is located in a pressure containing chamber, and is retained by the blowdown o-ring (30) and blowdown locknut (27). DO NOT remove the blowdown needle while under pressure.

6. Remove body vent and install a flexible tube in this port. Immerse this pilot discharge bubble tube in water approximately 1/4" below surface to detect cracking and reseal pressure.

7. A small interaction occurs between set pressure and blowdown adjustments. Re-adjustment of both may be required until the specified set pressure and blowdown are achieved. After completion, lock both screws and locknuts and replace closing cap (29) on adjusting screw (28).
8. Hold the valve at the set pressure while performing a soap bubble test of all bolted, flanged and threaded connections.
9. Refer to Table 3 for standard setting Specifications.

TABLE 3 SETTING SPECIFICATIONS - PILOT VALVE				
Pilot Action	Set Pressure	Set Pressure Limits	Maximum Cracking Pressure % of Set	Reseat Pressure % of Set
Snap	2" - 8" WC	+/- 0.2"WC	75	90 +/- 3
Snap	8.1" WC - 1.0 psig	+/- 3%	90	90 +/- 3
Snap	1.1 - 15.0 psig	+/- 3%	95	93 +/- 3
Modulating	2" - 8" WC	+/- 0.2" WC	75	100
Modulating	8.1" - 1.0 psig	+/- 3%	90	100
Modulating	1.1 - 15.0 psig	+/- 3%	95	100

**FIGURE 1
Pilot Valve Test Stand**

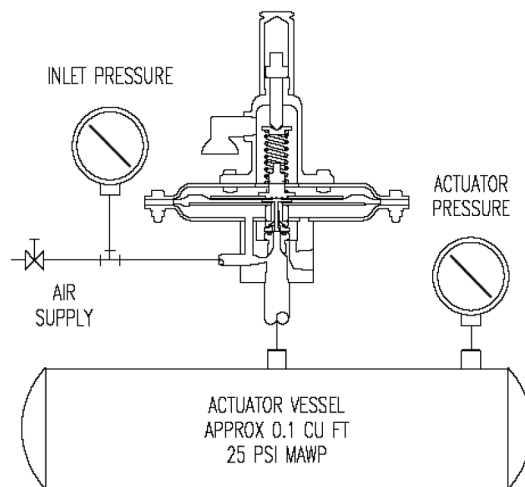
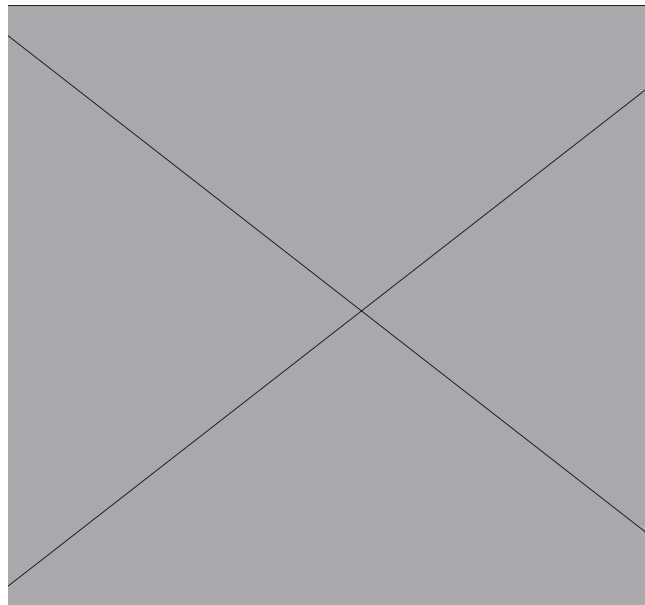
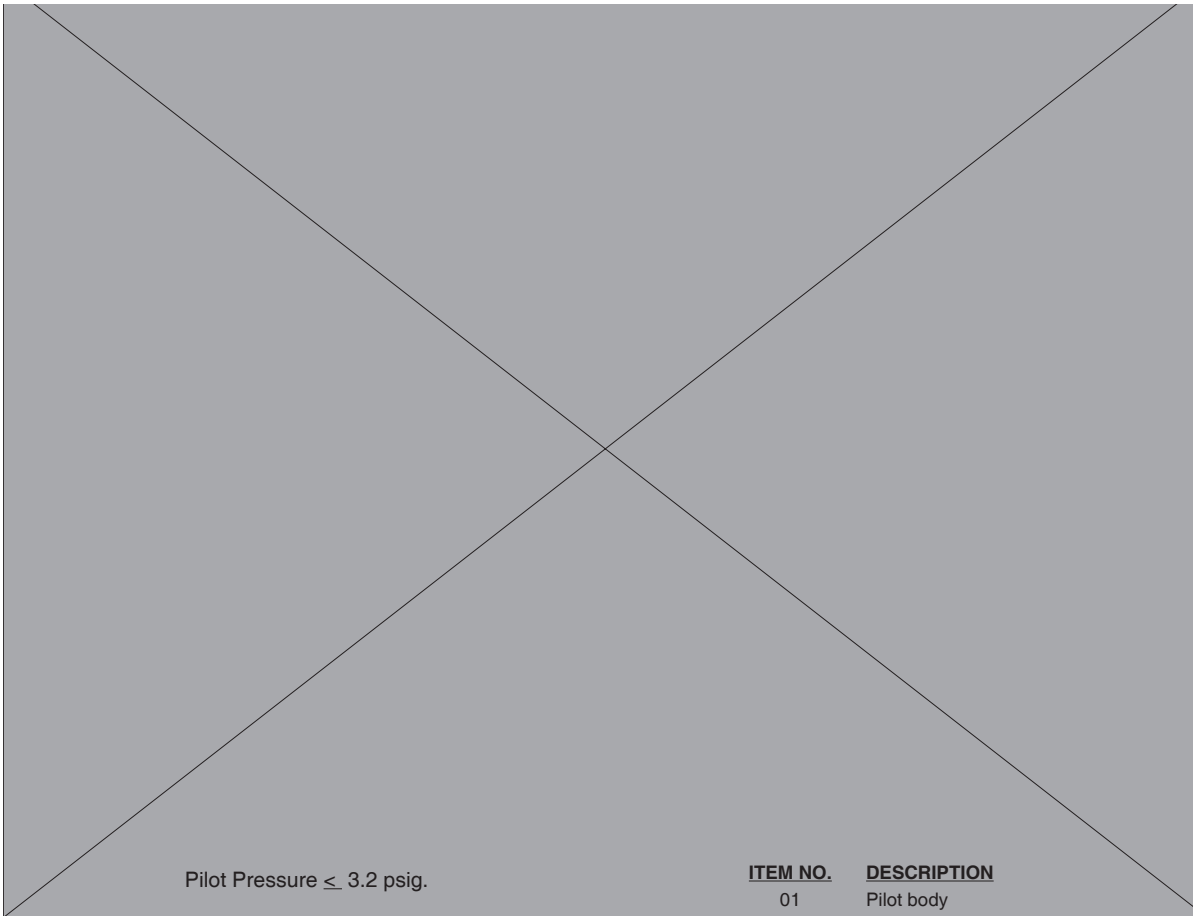

FIGURE 2 - PILOT VALVE



<u>ITEM NO.</u>	<u>DESCRIPTION</u>
01	Pilot body
02	Body gasket *
03	Lower diaphragm case
04	Cap screw
05	Seat o-ring *
06	Spindle assy.
07	Bolt gasket *
08	Seal diaphragm *
09	Boost diaphragm spacer
10	Boost diaphragm *
11	Support plate - Boost
12	Sense diaphragm spacer
13	Diaphragm case spacer
14	Sense diaphragm *
15	Sense pressure ring
16	Support plate - Sense
17	Lower spring guide
18	Spindle stud
19	Nut
20	Range spring
21	Spring button
22	Upper diaphragm case
23	Spring bonnet
24	Exhaust screen
25	Washer - Diaphragm case
26	Cap screw - Diaphragm case
27	Jam nut - Adjusting screw
28	Adjusting screw / Blow down needle
29	Closing Cap
30	O-ring - Blown down needle *
31	Exhaust fitting
32	Straight tube fitting
33	Compression elbow
34	Tubing
36	Boost Pressure Ring #

* Spare parts # Intermediate & High Pressure Pilots ONLY

FIGURE 3 - MAIN VALVE

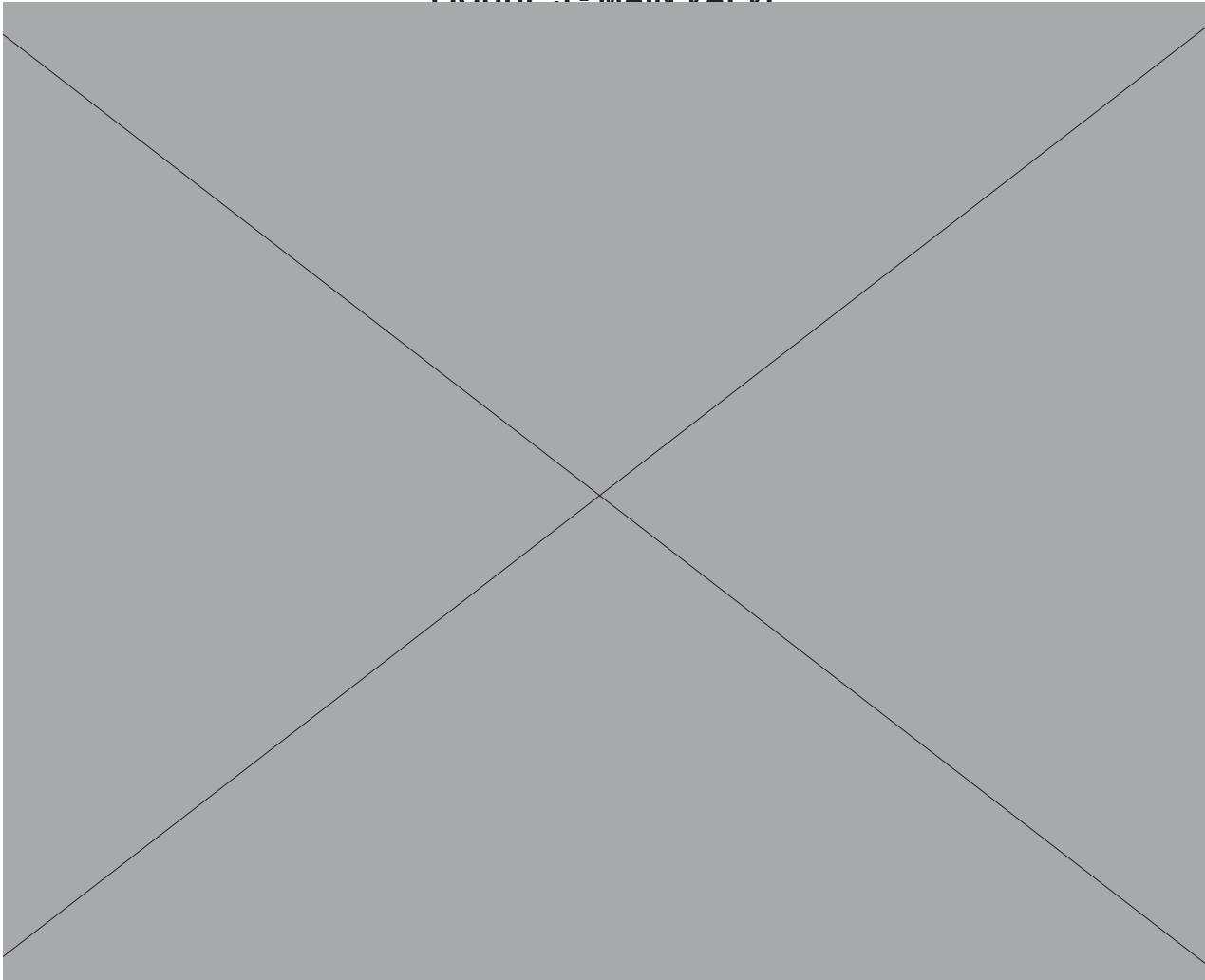

<u>ITEM NO.</u>	<u>DESCRIPTION</u>	<u>ITEM NO.</u>	<u>DESCRIPTION</u>
100	Body	122	Lower Act. case assy.
101	Seat ring	123	Cap screw
102	Seat ring bolts	124	Jack screw
103	Pressure stem	125	Jack nut
104	Vacuum stem	126	Jam nut - Jack screw
105	Stiffener plate	127	Support plate weldment
106	Pressure /Vacuum pallet	128	Act. Diaphragm *
107	Diaphragm *	129	Upper Act. case assy.
108	Diaphragm retainer - Pressure	130	Cap screw - Act. case
109	Diaphragm retainer - Vacuum	131	Nut - Act. case
110	Lock nut - pallet	132	Pilot mounting nipple
111	Pallet guide - Pressure	133	Nipple - Check valve
112	Pallet guide - Vacuum	134	Check valve
113	Pallet weight	135	Lifting bracket
114	Vacuum cover	136	Cap screw - Lifting bracket
115	Cap screw - Vacuum cover	137	Stud
116	Nipple - Vacuum cover	138	Sense tube connector 1
117	Nipple cover - Vacuum	139	Sense tube connector 2
118	Bug screen	140	Sense tube
119	Weatherhood	141	Name Plate
120	Weatherhood plate	142	Joint tape * See Figure 4.
121	Gasket - Actuator case *		

* Spare parts

OPTION 2 - Remote Sense

OPTION 1 - Manual Blow Down

SEE ITEM NO. & DESCRIPTION LIST on page 15.

OPTION 3 - Rotometer to Purge Pilot Sense

OPTION 4 - Air Assist

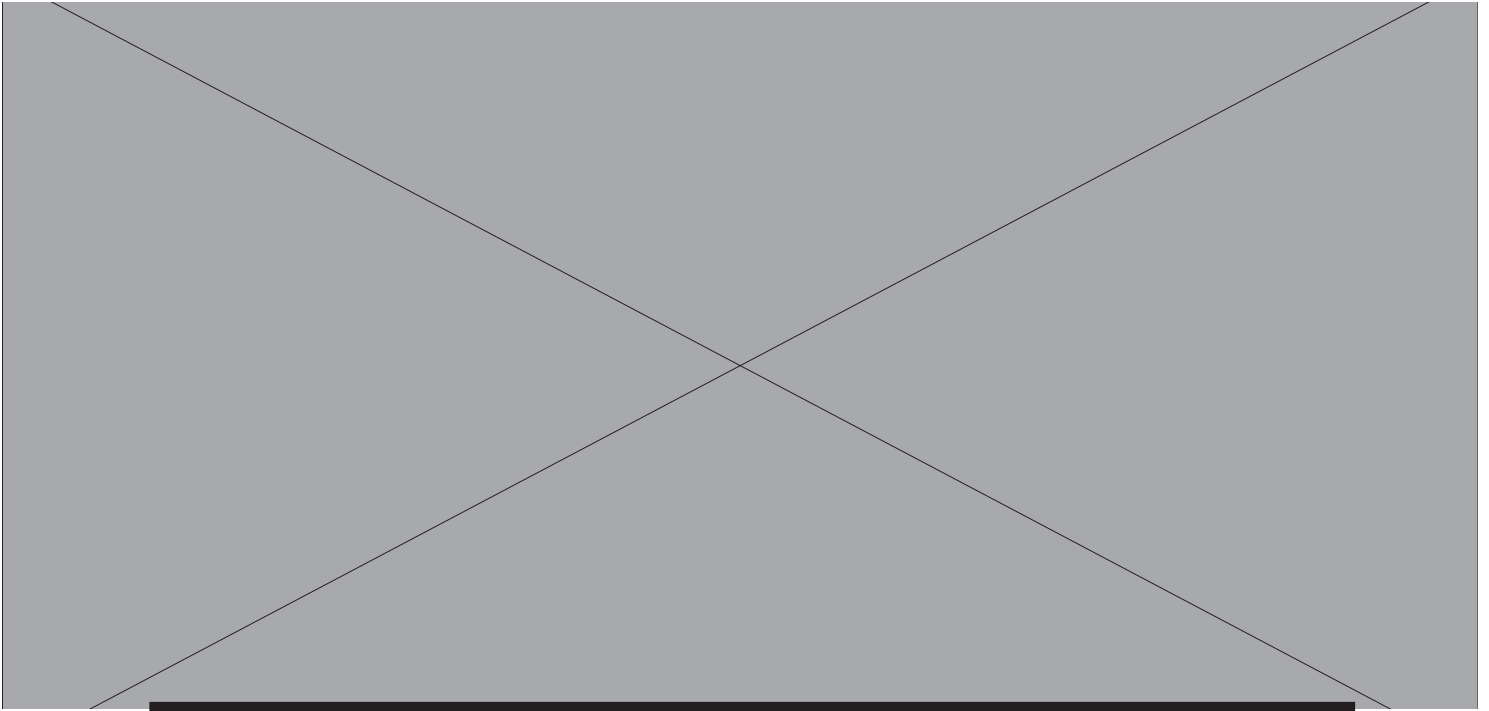

OPTION 5 - ATEX

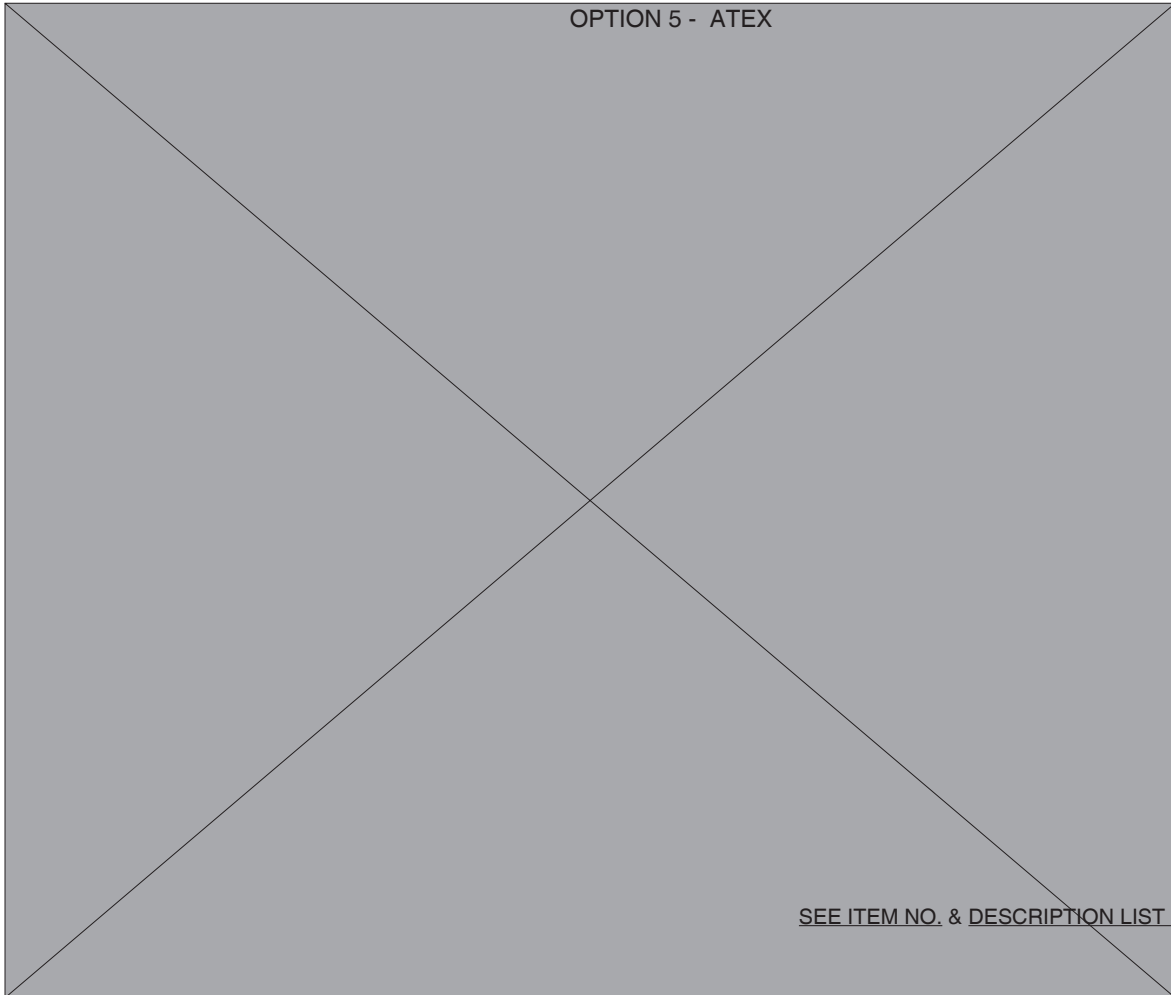

SEE ITEM NO. & DESCRIPTION LIST on page 15.

OPTION 6 - Field Test Connection

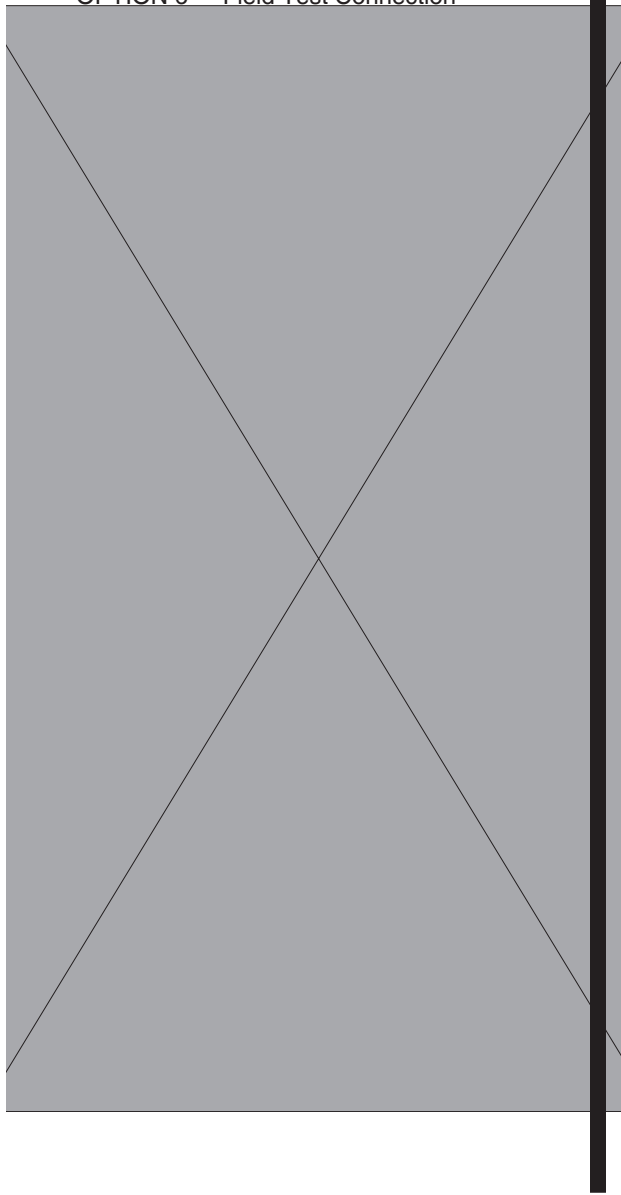
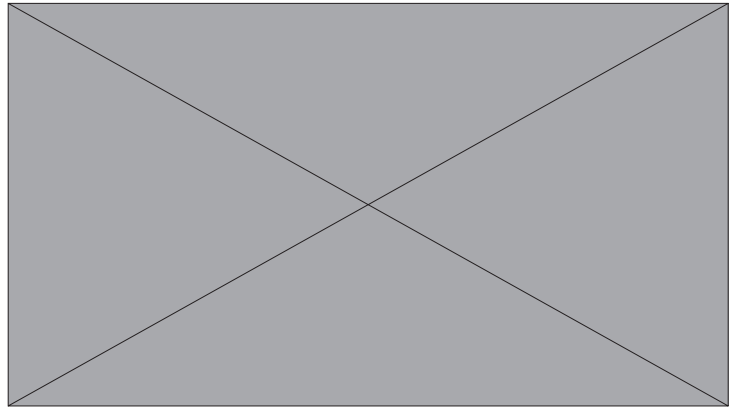
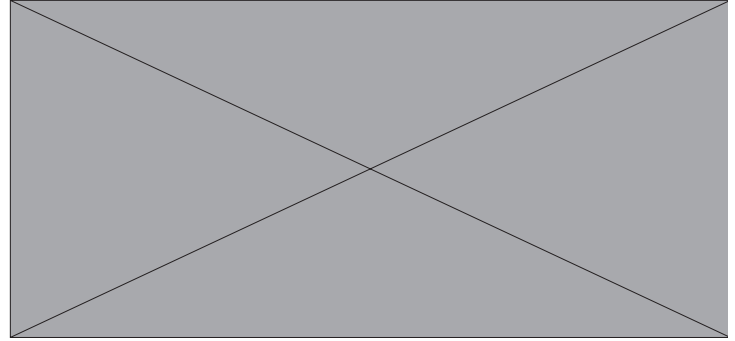

Figure 4 - Joint Tape Application



TFE TAPE LENGTH

Size	Item 142.0 *	Item 142.1 **
2"	23"	17"
3"	25"	20"
4"	33"	28"
6"	38"	34"
8"	46"	41"
10"	56"	47"
12"	58"	51"

* Quantity 1 per unit.

** Quantity 2 per unit.

ITEM NO.	DESCRIPTION
200	Plug - Remote sense
201	MNPT Tee - Manual blowdown
202	Ball valve - Manual blowdown
203	MNPT Tee - Field test conn.
204	Push lock air fitting - Field test
205	Nipple - Purge Opt.
206	Street Tee - Purge Opt.
207	Red. Bushing - Purge Opt.
208	MNPT Flow orifice - Purge Opt.
209	Purge meter - Purge Opt.
210	Pipe plug - Air assist
211	Sense tube conn. - FNPT Air assist

ITEM NO.	DESCRIPTION
212	Red. bushing - Air assist
213	Nipple - Air assist
214	Filter Reg. - Air assist
215	Red. bushing - Gauge - Air assist
216	Pressure gauge - Air assist
300	Pallet guide - Vacuum - ATEX
301	Cable eyelet 1 - ATEX
302	Cable eyelet 2 - ATEX
303	Screw - ATEX
304	Cable - Pressure - ATEX
305	Cable - Vacuum - ATEX

ADDENDUM - A

TIGHTENING SEQUENCE FOR FLANGE BOLTING

GUIDELINES FOR BOLTED FLANGE JOINT ASSEMBLY ACCORDING TO ASME PCC-1 SPECS

STEP	LOADING
Install	Hand tighten. Check flange gap around circumference for uniformity. If the gap is not reasonably uniform, make the appropriate adjustments by selective tightening before proceeding.
Round 1	Tighten to 20% to 30% of target torque. Check flange gap around circumference for uniformity. If the gap is not reasonably uniform, make the appropriate adjustments by selective tightening before proceeding.
Round 2	Tighten to 50% to 70% of target torque. Check flange gap around circumference for uniformity. If the gap is not reasonably uniform, make the appropriate adjustments by selective tightening before proceeding.
Round 3	Tighten to 100% of target torque. Check flange gap around circumference for uniformity. If the gap is not reasonably uniform, make the appropriate adjustments by selective tightening.

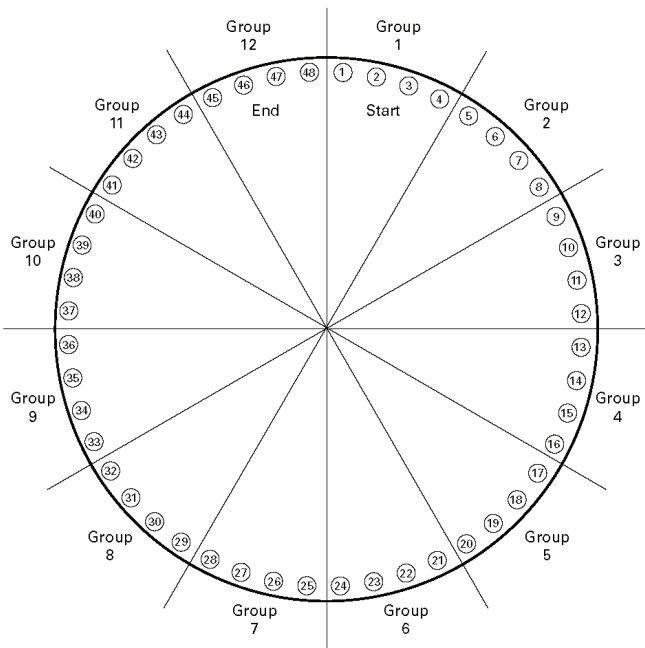

Group	Bolts
1	1-2-3-4
2	5-6-7-8
3	9-10-11-12
4	13-14-15-16
5	17-18-19-20
6	21-22-23-24
7	25-26-27-28
8	29-30-31-32
9	33-34-35-36
10	37-38-39-40
11	41-42-43-44
12	45-46-47-48

Tightening sequence for 12 Groups:

- 1-7-4-10 ↙ ↘
- 2-8-5-11 ↙ ↘
- 3-9-6-12

The 12-group sequence is the same as a 12-bolt sequence

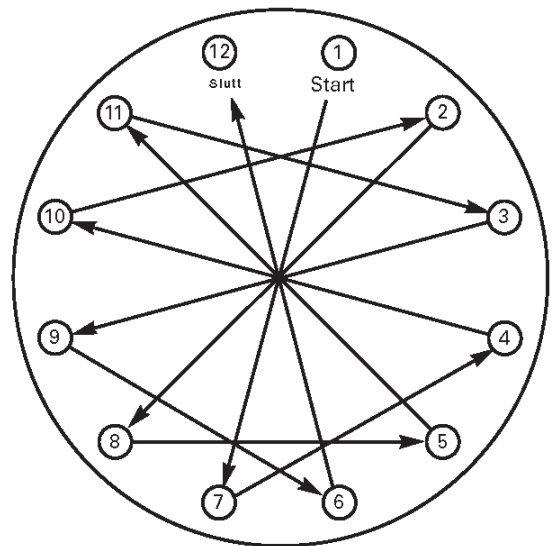

1-7-4-10 → 2-8-5-11 → 3-9-6-12

RECOMMENDATIONS FOR PROPER GASKET INSTALLATION

Gasket seating surfaces for tank nozzle flange must be clean, free of scratches, corrosion, tool marks and flat. Use either a full faced or ring gasket for steel and stainless steel raised face flanges

FRP and Aluminum vents are furnished with flat faced flanges. It is recommended that they be installed on mating flat face flanges with a full faced gasket. If the flat face of the vent is sealing against a raised face steel flange, a spacer or filler ring must be used to fill the annular space of the raised face steel flange.

Refer to Gasket Dimension Table.

Ensure that the gasket material is suitable for the service. Make sure that the gasket is compressed evenly and the flanges are not distorted. Utilizing proper torquing techniques will ensure a tight seal and prevent leakage around the gasket. See preceding page.

NOTE: *Incorrect positioning and/or selection of gasket(s) between the flanges will cause bending stresses at the flange that may damage the flange joint as bolting is tightened. This is more likely to occur with aluminum or cast iron materials.*

Correct Installation

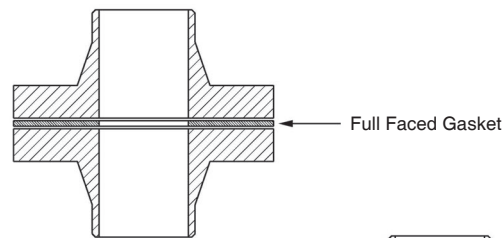

Incorrect Installation

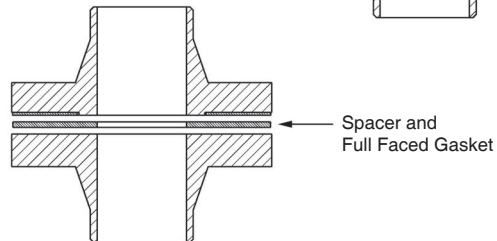
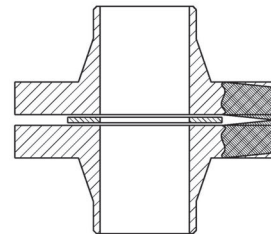

Correct Installation

ATEX 94/9/EC: Explosive Atmospheres and Cashco Inc. Regulators

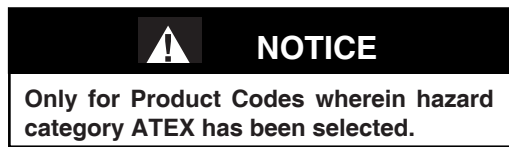

These valves satisfy the safety conditions according to EN 13463-1 and EN 13463-5 for equipment group IIG 2 c.

Caution: Because the actual maximum temperature depends not on the equipment itself, but upon the fluid temperature, a single temperature class or temperature cannot be marked by the manufacturer.

Specific Precaution to Installer: Electrical grounding of valve must occur to minimize risk of effective electrical discharges.

Specific Precaution to Installer: Atmosphere vent holes should be plugged to further minimize the risk of explosion.

Specific Precaution to Maintenance: The Valve Body/ Housing must be regularly cleaned to prevent buildup of dust deposits.

Specific Precaution to Maintenance: Conduct periodic Continuity Check between Valve Body/ Housing and Tank to minimize risk of electrical discharges.

Attention: When repairing or altering explosion-protected equipment, national regulations must be adhered to. For maintenance and repairs involving parts, use only manufacturer's original parts.

ATEX requires that all components and equipment be evaluated. Cashco pressure regulators are considered components. Based on the ATEX Directive, Cashco considers the location where the pressure regulators are installed to be classified Equipment-group II, Category 3 because flammable gases would only be present for a short period of time in the event of a leak. It is possible that the location could be classified Equipment-group II, Category 2 if a leak is likely to occur. Please note that the system owner, not Cashco, is responsible for determining the classification of a particular installation.

Product Assessment

Cashco performed a conformity assessment and risk analysis of its pressure regulator and control valve models and their common options, with respect to the Essential Health and Safety Requirements in Annex II of the ATEX directive. The details of the assessment in terms of the individual Essential Health and Safety Requirements, are listed in Table 1. Table 2 lists all of the models and options that were evaluated and along with their evaluation.

Models and options not listed in Table 2 should be assumed to not have been evaluated and therefore should not be selected for use in a potentially explosive environment until they have been evaluated.

Standard default options for each listed model were evaluated even if they were not explicitly listed as a separate option in the table. Not all options listed in the tables are available to all models listed in the tables. Individual TB's must be referenced for actual options.

When specifying a regulator that is to be used in a potentially explosive environment one must review the evaluations in Table 1 and 2 for the specific model and each and every option that is being specified, in order to determine the complete assessment for the unit.

A summary of the models and options found to have an impact on ATEX assessment due to potential ignition sources or other concerns from the ATEX Essential Health and Safety Requirements, are listed below.

1. The plastic knob used as standard on some models, (P1, P2, P3, P4, P5, P7, 3381, 4381, 1171, and 2171) is a potential ignition source due to static electricity. To demonstrate otherwise, the knob must be tested to determine if a transferred charge is below the acceptable values in IEC 60079-0 Section 26.14 (See items 25, 27, and 28 in Appendix A). Until the plastic knob has been shown to be acceptable, then either the metal knob option, or a preset outlet pressure option is required to eliminate this ignition source (See items 45 and 64 in Tables).
2. The pressure gauges offered as options on a few of the regulator models (DA's, P1-7, D, 764, 521), use a plastic polycarbonate window that is a potential ignition source due to static electricity. To demonstrate that the gauges are not a potential source of ignition, the gauges would need to be tested to determine if a transferred charge is below the acceptable values in IEC 60079-0 Section 26.14 or the pressure gauge supplier must provide documentation

indicating the gauge is compliant with the ATEX Directive (See items 26, 27, and 28 in Appendix A). Until compliance is determined, regulators should not be ordered with pressure gauges for use in potentially explosive environments.

3. Tied diaphragm regulators with outlet ranges greater than 100 psig should be preset to minimize the risk that improper operation might lead to an outboard leak and a potentially explosive atmosphere (See item 6 in Table 1).
4. Regulators must be ordered with the non-relieving option (instead of the self-relieving option) if the process gas they are to be used with is hazardous (flammable, toxic, etc.). The self-relieving option vents process gas through the regulator cap directly into the atmosphere while the non-relieving option does not. Using regulator with the self-relieving option in a flammable gas system could create an explosive atmosphere in the vicinity of the regulator.
5. Regulators with customer supplied parts are to be assumed to not have been evaluated with regard to ATEX and thus are not to be used in a potentially explosive environment unless a documented evaluation for the specific customer supplied parts in question has been made. Refer to Table 1 for all models and options that have been evaluated.

Product Usage

A summary of ATEX related usage issues that were found in the assessment are listed below.

1. Pressure regulators and control valves must be grounded (earthed) to prevent static charge build-up due to the flowing media. The regulator can be grounded through any mounting holes on the body with metal to metal contact or the system piping can be grounded and electrical continuity verified through the body metal seal connections. Grounding of the regulator should follow the same requirements for the piping system. Also see item 30 in Table 1.
2. The system designer and users must take precautions to prevent rapid system pressurization which may raise surface temperatures of system components and tubing due to adiabatic compression of the system gas.
3. Heating systems installed by the user could possibly increase the surface temperature and must be evaluated by the user for compliance with the ATEX Directive. User installation of heating systems applied to the regulator body or system piping that affects the surface temperature of the pressure regulator is outside the scope of this declaration and is the responsibility of the user.
4. The Joule-Thomson effect may cause process gases to rise in temperature as they expand going through a regulator. This could raise the external surface temperature of the regulator body and downstream piping creating a potential source of ignition. Whether the Joule-Thomson effect leads to heating or cooling of the process gas depends on the process gas and the inlet and outlet pressures. The system designer is responsible for determining whether the process gas temperature may rise under any operating conditions. If a process gas temperature rise is possible under operating conditions, then the system designer must investigate whether the regulator body and downstream piping may increase in temperature enough to create a potential source of ignition.

The process gas expansion is typically modeled as a constant enthalpy throttling process for determining the temperature change. A Mollier diagram (Pressure – Enthalpy diagram with constant temperature, density, & entropy contours) or a Temperature – Entropy diagram with constant enthalpy lines, for the process gas, can be used to determine the temperature change. Helium and hydrogen are two gases that typically increase in temperature when expanding across a regulator. Other gases may increase in temperature at sufficiently high pressures.

Product Declaration

If the above issues are addressed by selecting options that do not have potential sources of ignition, avoiding options that have not been assessed, and by taking the proper usage issue precautions, then Cashco regulators can be considered to be a mechanical device that does not have its own source of ignition and thus falls outside the scope of the ATEX directive.

Cashco, Inc.
P.O. Box 6
Ellsworth, KS 67439-0006
PH (785) 472-4461
Fax. # (785) 472-3539
www.cashco.com
email: sales@cashco.com
Printed in U.S.A. 5100-IOM

Cashco GmbH
Handwerkerstrasse 15
15366 Hoppegarten, Germany
PH +49 3342 30968 0
Fax. No. +49 3342 30968 29
www.cashco.com
email: germany@cashco.com

Cashco do Brasil, Ltda.
Al.Venus, 340
Indaiatuba - Sao Paulo, Brazil
PH +55 11 99677 7177
Fax. No.
www.cashco.com
email: brazil@cashco.com