



Model 3700

BOTTOM GUIDED Emergency Relief Vent

Valve Concepts, Inc.
ISO Registered Company

SECTION I

I. 3000 SERIES DESIGN AND FUNCTION

MODEL	P	V	DESCRIPTION
3100	P	V	Vent to Atmosphere
3200	P	V	Vent to Header
3300		V	Top Mounted
3400	P		Vent to Atmosphere
3500	P		Vent to Header
3600		V	Side Mounted
3700	P		Emergency/Bottom Guided Relief

Models 3100 through 3600 Pressure and/or Vacuum Vents are used for the normal venting requirements. Normal venting is defined as venting required because of operational requirements (i.e. filling and emptying the tank) or atmospheric changes. The Model 3700 Emergency Relief Vent is used to meet additional venting required when an abnormal condition, such as an external fire or such as ruptured internal heating coils, exist either outside or inside the tank.

All of these devices are sized in accordance with API Standard 2000. Improperly specified relief vents may result in structural damage to the tank or system and can cause severe personal injury or death.

Figure 1 illustrates the operation of the Pressure/Vacuum Relief Vent under overpressure conditions. As the tank pressure increases as a result of product being pumped into the tank and/or because of thermal expansion of the product and vapors, the pressure pallet remains closed until the set pressure of the vent is reached. When the tank pressure reaches the pressure setting of the vent, the pressure pallet lifts allowing the tank pressure to bleed off.

Figure 2 illustrates the operation of the Pressure/Vacuum Relief Vent under vacuum conditions. As the tank pressure decreases as a result of product being pumped out of the tank and/or because of thermal contraction of the product and vapors, the vacuum pallet remains closed until the set vacuum of the vent is reached. When the tank vacuum reaches the vacuum setting of the vent, the vacuum pallet lifts allowing air to be drawn into the tank.

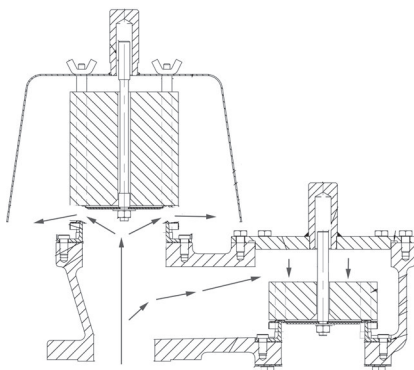

Figure 1 - Pressure Relief

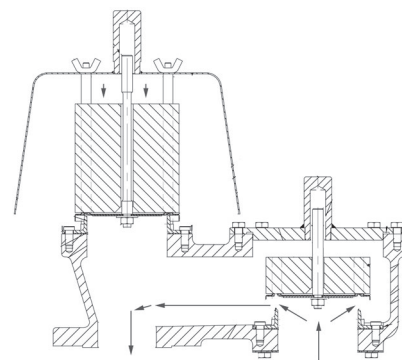

Figure 2 - Vacuum Relief

SECTION II

II. SAFETY WARNINGS

Tank or system protection is the primary function of the weight loaded Pressure and/or Vacuum Relief Vent. It must be selected to meet the total pressure and vacuum flow requirements within the Maximum Allowable Working Pressure and Vacuum of the system on which it is installed. Consult API Standard 2000 for tank protection sizing procedures. Improperly specified relief vents may result in structural damage to the tank or system and can cause severe personal injury or death.

When Pipe-Away relief vents are used, back pressure in the header system will affect the set point of weight loaded vents by the amount of the header pressure. Maximum possible header pressure must be considered when sizing the pressure relief vent.



CAUTION

DO NOT attempt to remove the emergency vent from the tank or process vessel without first bleeding all pressure from the system. ALTERNATIVE MEANS OF PRESSURE RELIEF MUST BE PROVIDED WHEN THE VENT IS OUT OF SERVICE.



CAUTION

DO NOT change pressure ratings by adding additional weight to the pallet assembly without consulting Cashco Inc. or your VCI representative.

SECTION III

III. INSPECTION AND STORAGE

The emergency relief vent is carefully packaged to prevent damage or contamination during shipping. Inspect the equipment when it is received and report any damage to the carrier immediately. The vent should be stored with all the protective covers in

place. Make sure that any loading weights that might have been shipped separately, to protect the vent during shipping, are accounted for and stored with the vent. All supplied weights should be installed during installation. See Section IV.

SECTION IV

IV. INSTALLATION



WARNING

The Model 3700 must be installed in a vertical position. The tank nozzle on which the vent is mounted should have the same nominal diameter as the venting device. It is recommended that the tank nozzle flange face be within 1 degree of horizontal for best performance of the venting device.

Before installation, remove all packing materials from inside and outside the emergency vent.

Inspect the gasket seating surface of the tank nozzle flange. It must be clean, free of scratches, corrosion, tool marks and flat.

The standard flange base for Model 3700 is designed to mate to a flange. This ERV is **NOT** rated for full flange pressure and does not require high bolting torque. Refer to flange torque guidelines on page 3.

Model 3700 Vents are furnished with flat faced flanges. It is recommended that they be installed on mating flat face flanges with a full faced gasket. If the flat face of the vent is sealing against a raised face steel flange, a spacer or filler ring must be used to fill the annular space of the raised face steel flange. Refer to flange torque guidelines on page 3.

Make sure the gasket is suitable for the application and is in good condition.

Fiberglass flanges require the use of a full-face 150 lb. gasket. For full face gaskets, we recommend the use of a 1/8-inch thick PTFE expanded gasket.

Center the gasket within the bolt circle of the tank flange and carefully set the emergency vent on the flange nozzle and align the bolt holes.

NOTE: At installation, the vent valve should be carefully lifted into position using the lifting brackets (2) on the body.

	CAUTION
<p>The lifting brackets should only be used for lifting the vent valve into place and should NOT be used for any other purpose.</p>	

All stud threads must be lubricated to obtain proper torque results. A washer should be used under each stud nut.

Install the studs, washers and nuts and tighten nuts hand tight. Check proper alignment of flange faces. Misalignment of flange faces will cause bending stresses at the flange and flange joint and damage may result. Correct any misalignment prior to applying torque to nuts.

All nuts must be tightened in proper sequence and in equal increments. Proceed through the tightening sequence until the recommended torque is attained.

Recheck the torque on each bolt in the same sequence, as bolts previously tightened may have relaxed through the torque sequence.

Place all supplied weights on top of the pallet.

Gasket Dimensions

FLANGE		O.D. in.	I.D. in.	B.C. in	Bolt Hole in.	Quantity
SIZE	TYPE					
16"	ASME 150#	23.50	16.00	21.25	1.13	16
18"		25.00	18.00	22.75	1.25	16
20"		27.50	20.00	25.00	1.25	20
24"		32.00	24.00	29.50	1.38	20
20"	API 650 150#	26.00	20.00	23.50	.75	16
24"		30.00	24.00	27.50	.75	20

Flange Torque Requirements for Aluminum and Stainless Steel Vents			
Flange Type	Size	Bolt (in) (UNC)	Torque (ft-lbs)
			Raised Face *
150# ASME	16"	1" - 8	201
	18"	1.125" - 7	286
	20"		
	24"	1.250" - 7	403
API # 650	20"	5/8" - 11	35
	24"	5/8" - 11	43
<p>* Flat Face Flange may require up to 80% more torque than Raised Face Flange. (Dependent on type of gasket used, the gasket material and thickness.)</p>			

SECTION V

V. MAINTENANCE

As a safety device, it is very important that maintenance/inspection be done on a regular interval for Emergency Vents. Maintenance should only be done by a qualified technician. Valve Concepts recommends that all service be performed at the factory or a factory authorized repair center. For information on repair centers in your area, please contact factory.

Any maintenance requires that the ERV be removed to a work area for disassembly. Use an overhead hoist with cables attached to the lifting brackets to lift unit and place on a flat work surface.

Rotate cap screws (08) counter clockwise to remove. Thread an eyenut onto the threads of the pallet cap screw. Connect a cable with hoist to the eyenut and carefully lift pallet assembly and weights off the flange seat (01) and place on a flat work surface.



CAUTION

The weight of the pallet assembly with loading weights may be considerable, and is contingent on the set point of the vent. Utilize caution when lifting from the base.

Diaphragm Inspection / Replacement:

Rotate jam nut (13) counter clockwise to remove. Remove washer (15).

Remove loading weights (14) that may be stacked on the pallet (03). **NOTE:** *Maintain stack orientation, do not remove or add any weight as that will change the factory calibrated pressure setpoint.*

Remove cap screw (12), gasket (09) and washers (15) from center of pallet assembly. Turn pallet assembly over and lay it flat so pallet guides (33) are upwards.

Remove cap screws (34) and detach pallet guides (33). Remove cap screws (05) and nuts (07) and gasket (06), so the diaphragm retainer (04) can be separated from the pallet (03) and diaphragm(s) (02). **NOTE:** *Pressure set point will dictate the quantity and stack orientation of diaphragms.* Record the number of diaphragm's in the stack and orientation for re-assembly. _____

Clean and inspect pallet (03) and diaphragm retainer (04).

Position the pallet (03) on a flat work surface, grooved side up. Apply TFE paste around hole in the center of the pallet (03) and lay the diaphragm(s) (02) onto the pallet, align with the center hole. **NOTE:** *Refer back to previous step for the number of diaphragms in the stack and orientation.*

Lay diaphragm retainer (04) on top of the new diaphragms (02). Replace gasket (06). Refasten nuts (07) to cap screws (05). Reattach the pallet guides (33) using the cap screws (34). Tighten nuts and cap screws to 4 ft./lbs.

Turn pallet assembly over. Position the washers (15) and the stack of pallet weights (14) on top of the pallet (03), align with the center hole. Insert the cap screw (12) with gasket (09) from below the pallet through the center hole in the diaphragms, pallet, and weights. Slide another washer (15) over the end of the cap screw (12). Rotate jam nut (13) CW, secure tight against pallet weights.

Clean and inspect seating surface on the flange seat (01). Use a Scotch-Brite pad first and then a clean cloth with Easy Clean sprayed on it. Check seat surface for any nicks, corrosion, pitting or product build up. Seat surfaces must be clean and smooth for vent to perform properly.

Thread an eyenut onto the threads of the pallet cap screw(12). Connect a cable with hoist to the eyenut and carefully lift and position pallet assembly into the flange base. Align holes for cap screws (08) in the flange base with the opening in the center of each pallet guide (33).

Thread cap screws (08) into the flange base and secure tight.

Return to Section IV for installation.

SECTION VI

VI. TEST PROCEDURE

To Calculate Weight of Pallet Assembly:

Table 2 shows the pallet weight per unit of pressure or vacuum setting. The total pallet assembly weight is determined by multiplying the desired set point (in the appropriate units) by the incremental weight per unit listed in Table 2.

For Example:

___" Model 370D CS - if the desired setting is 5 oz/in²

Table 2 shows that for a 20" vent, the pallet would weigh 20.13 lb per oz/in²

So the pallet assembly for a 5 oz/in² setting would weigh: 20.13 lbs/oz/in² x 5.0 oz./in² - 100.65 lbs

Valve Concepts allows a deviation from this theoretical weight of ± 3.0%.

To Determine Diaphragm/Seat Leakage:

After both pallets' weight has been determined and verified for the required setting, reassemble the vent and mount on a Tank Vent Test Stand and slowly raise the pressure at the flow rate per API Standard 2000.

ACCEPTANCE CRITERIA:

The pressure gauge shall maintain a pressure equal to or greater than 75% of set pressure for a one minute period while the specified flow rate is maintained. Note: Valve Concepts acceptance criteria meets or exceeds the requirements of API. API 2521 states that if the rate of leakage does not exceed ½ SCFH for 6 inch size and smaller, 5 SCFH for 8 inch to 16 inch, or 20 SCFH for larger than 16 inch, at 75% of set point, then a vent is considered satisfactory for all practical purposes.

A test report should be completed for each vent. The report should indicate the total pallet weight and the pressure achieved at the Test Flow Rate for both pressure and vacuum. Other general information such as serial number, model number, material of construction, set pressure and vacuum, etc. should be included in the report.

The test report should be kept with the Vent Maintenance Records.

**TABLE 2
Nominal Pallet Assembly Weight Per Unit of Pressure lbs (kg)**

SET Point Units	Size			
	16"	18"	20"	24"
	Lb (kg)	Lb (kg)	Lb (kg)	Lb (kg)
1.0 oz/in ²	13.56 (6.5)	17.04 (7.7)	20.13 (9.1)	28.87 (13.1)
1.0 in WC	7.85 ((3.6)	9.85 (4.5)	11.63 (5.2)	16.69 (7.5)
1.0 mbar	3.15 (1.4)	3.95 (1.8)	4.67 (2.1)	6.70 (3.0)

SECTION VII

VII. ORDERING INFORMATION

NEW REPLACEMENT UNIT vs PARTS "KIT" FOR FIELD REPAIR

To obtain a quotation or place an order, please retrieve the Serial Number and Product Code that was stamped on the metal name plate and attached to the unit. This information can also be found on the Bill of Material ("BOM"), a parts list that was provided when unit was originally shipped. (Serial Number typically 6 digits).

NEW REPLACEMENT UNIT:

Contact your local Cashco, Inc., Sales Representative with the Serial Number, Product code and the pressure setting. With this information they can provide a quotation for a new unit including a complete description, price and availability.

PARTS "KIT" for FIELD REPAIR:

Contact your local Cashco, Inc., Sales Representative with the Serial Number and Product code. Identify the parts and the quantity required to repair the unit from the "BOM" sheet that was provided when unit was originally shipped.

If the "BOM" is not available, refer to the cross-sectional drawings included in this manual for part identification and selection.

A Local Sales Representative will provide quotation for appropriate Kit Number, Price and Availability.



CAUTION

Do not attempt to alter the original construction of any unit without assistance and approval from the factory. All proposed changes will require a new name plate with appropriate ratings and new product code to accommodate the recommended part(s) changes.

MODEL 3700 EMERGENCY RELIEF VENT Aluminum Base

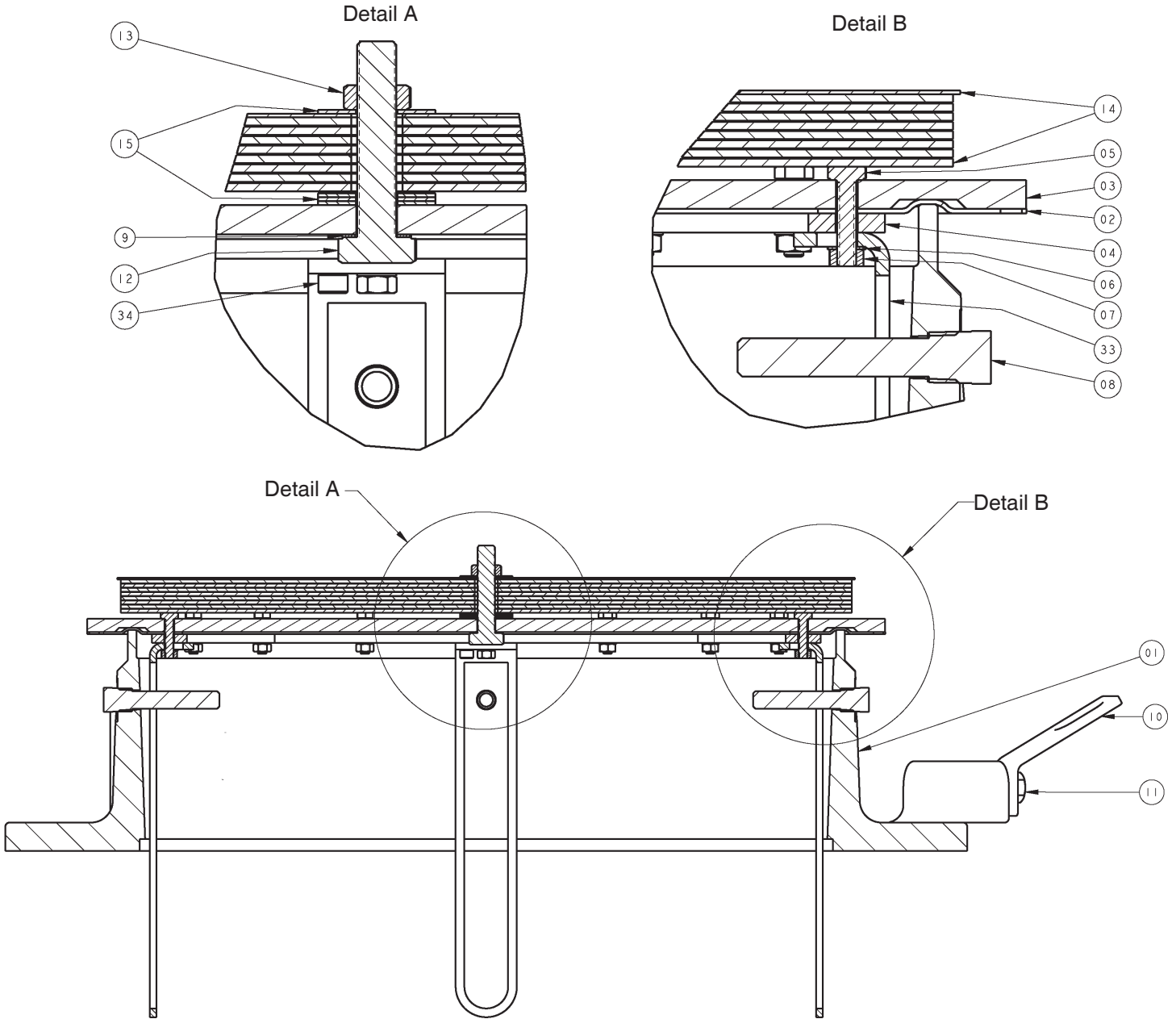

ITEM NO. DESCRIPTION

01	Flange Seat
02	Diaphragm ‡
03	Pallet
04	Diaphragm Retainer / Guide
05	Cap Screw
06	Gasket ‡
07	Nut
08	Cap Screw
09	Gasket ‡
10	Lift Bracket

ITEM NO. DESCRIPTION

11	Cap Screw
12	Cap Screw
13	Jam Nut
14	Pallet Weight
15	Washer
17	ATEX Cable (Optional)
33	Pallet Guide
34	Cap Screw

‡ Typical Parts required for inspection and rebuild.

MODEL 3700 EMERGENCY RELIEF VENT
Fabricated Steel & Stainless
Steel Base

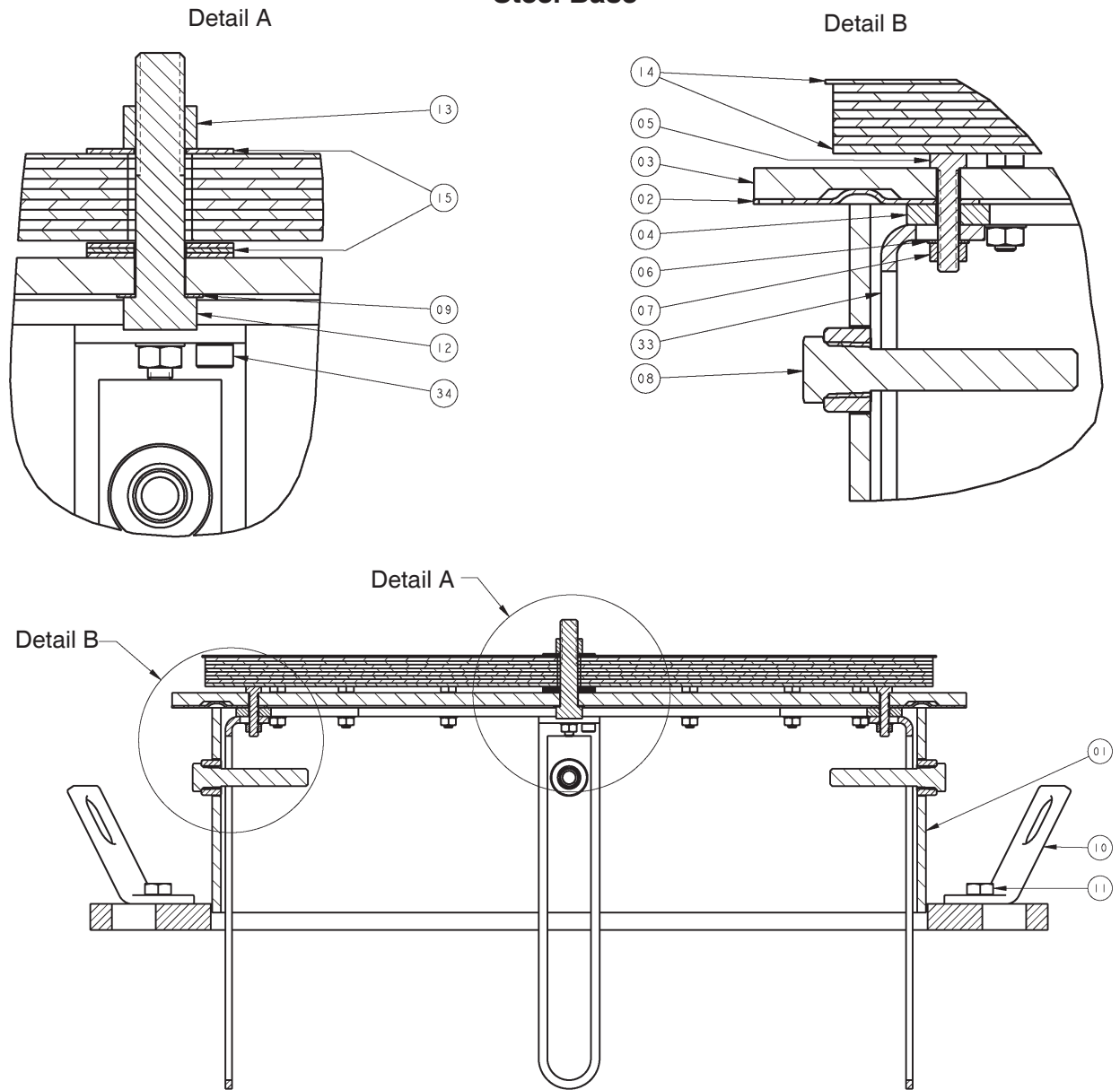

ITEM NO. DESCRIPTION

01	Flange Seat
02	Diaphragm ‡
03	Pallet
04	Diaphragm Retainer / Guide
05	Cap Screw
06	Gasket ‡
07	Nut
08	Cap Screw
09	Gasket ‡
10	Lift Bracket

ITEM NO. DESCRIPTION

11	Cap Screw
12	Cap Screw
13	Jam Nut
14	Pallet Weight
15	Washer
17	ATEX Cable (Optional)
33	Pallet Guide
34	Cap Screw

‡ Typical Parts required for inspection and rebuild.

VENT with ATEX CABLE

Aluminum Base

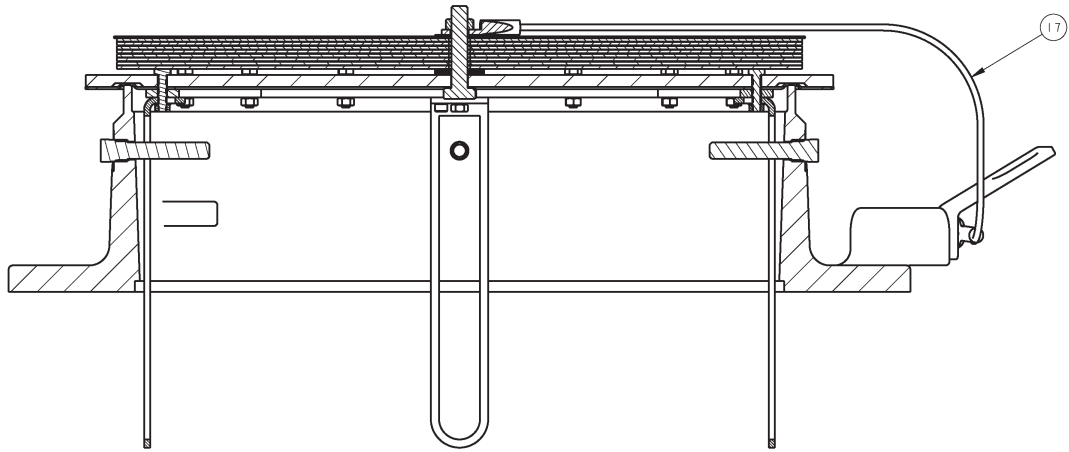

Steel & Stainless Steel Base

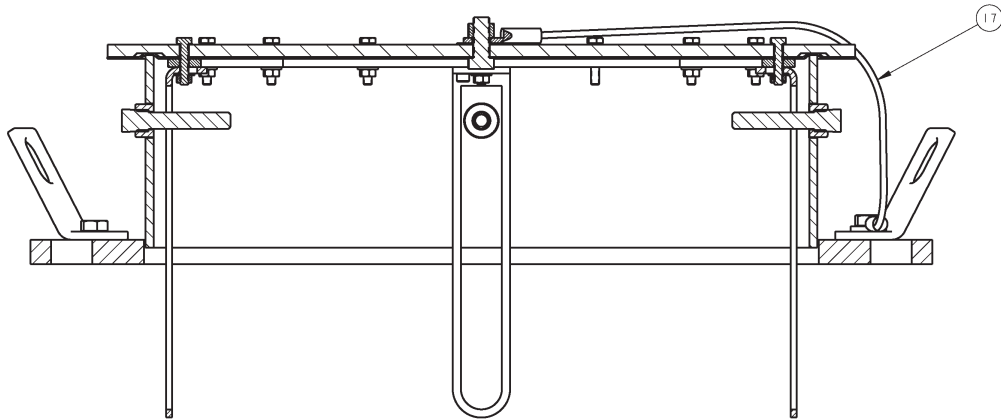

ADDENDUM - A

TIGHTENING SEQUENCE FOR FLANGE BOLTING

GUIDELINES FOR BOLTED FLANGE JOINT ASSEMBLY ACCORDING TO ASME PCC-1 SPECS

STEP	LOADING
Install	Hand tighten. Check flange gap around circumference for uniformity. If the gap is not reasonably uniform, make the appropriate adjustments by selective tightening before proceeding.
Round 1	Tighten to 20% to 30% of target torque. Check flange gap around circumference for uniformity. If the gap is not reasonably uniform, make the appropriate adjustments by selective tightening before proceeding.
Round 2	Tighten to 50% to 70% of target torque. Check flange gap around circumference for uniformity. If the gap is not reasonably uniform, make the appropriate adjustments by selective tightening before proceeding.
Round 3	Tighten to 100% of target torque. Check flange gap around circumference for uniformity. If the gap is not reasonably uniform, make the appropriate adjustments by selective tightening.

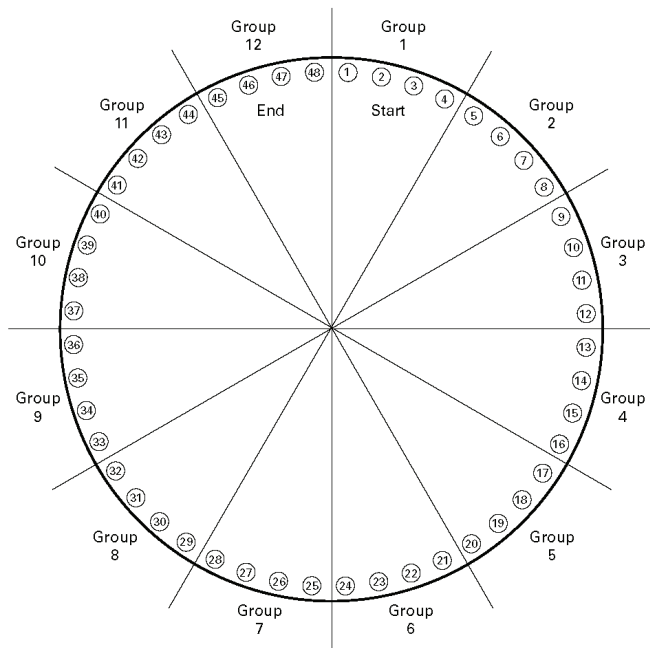

Group	Bolts
1	1-2-3-4
2	5-6-7-8
3	9-10-11-12
4	13-14-15-16
5	17-18-19-20
6	21-22-23-24
7	25-26-27-28
8	29-30-31-32
9	33-34-35-36
10	37-38-39-40
11	41-42-43-44
12	45-46-47-48

Tightening sequence for 12 Groups:
 1-7-4-10 ↙
 2-8-5-11 ↙
 3-9-6-12

The 12-group sequence is the same as a 12-bolt sequence

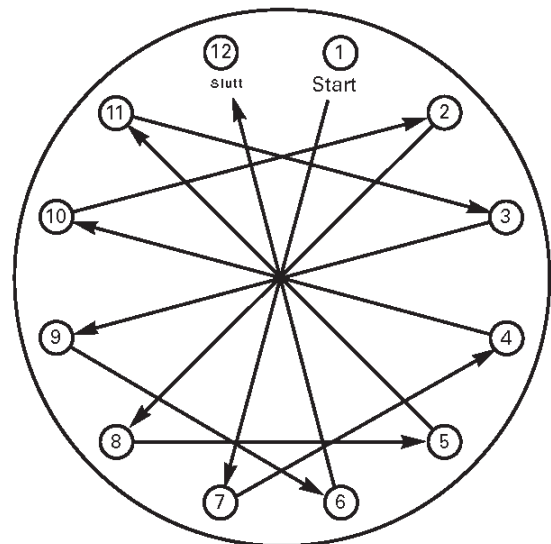

1-7-4-10 → 2-8-5-11 → 3-9-6-12

RECOMMENDATIONS FOR PROPER GASKET INSTALLATION

Gasket seating surfaces for tank nozzle flange must be clean, free of scratches, corrosion, tool marks and flat. Use either a full faced or ring gasket for steel and stainless steel raised face flanges.

FRP and Aluminum vents are furnished with flat faced flanges. It is recommended that they be installed on mating flat face flanges with a full faced gasket. If the flat face of the vent is sealing against a raised face steel flange, a spacer or filler ring must be used to fill the annular space of the raised face steel flange.

Refer to Gasket Dimension Table.

Ensure that the gasket material is suitable for the service. Make sure that the gasket is compressed evenly and the flanges are not distorted. Utilizing proper torquing techniques will ensure a tight seal and prevent leakage around the gasket. See preceding page.

NOTE: *Incorrect positioning and/or selection of gasket(s) between the flanges will cause bending stresses at the flange that may damage the flange joint as bolting is tightened. This is more likely to occur with aluminum or cast iron materials.*

Correct Installation

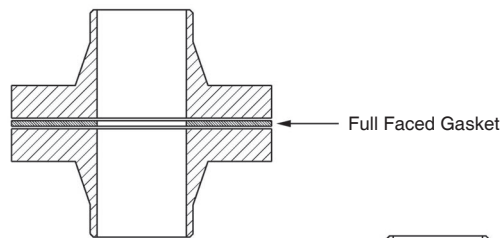

Incorrect Installation

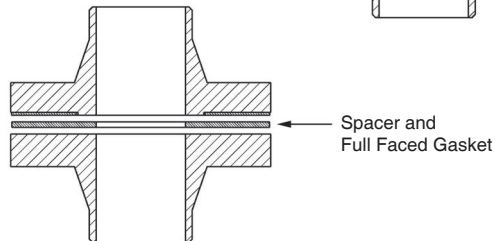
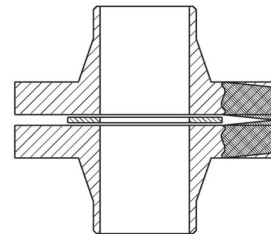

Correct Installation

The contents of this publication are presented for informational purposes only, and while every effort has been made to ensure their accuracy, they are not to be construed as warranties or guarantees, express or implied, regarding the products or services described herein or their use or applicability. We reserve the right to modify or improve the designs or specifications of such product at any time without notice. Cashco, Inc. does not assume responsibility for the selection, use or maintenance of any product. Responsibility for proper selection, use and maintenance of any Cashco, Inc. product remains solely with the purchaser.

ATEX 2014/34/EU: Explosive Atmospheres and Cashco Inc. Products



Cashco, Inc. declares that the products listed in the table below has been found to comply with the Essential Health and Safety Requirements relating to the design and construction of products intended for use in potentially explosive atmospheres given in Annex II of the ATEX Directive 2014/34/EU. Compliance with the Essential Health and Safety Requirements has been assured by compliance with EN ISO 80079-36:2016 and EN ISO 80079-37:2016. The product will be marked as follows:

CE Ex II 2 G
Ex h IIB T6... T1 Gb
1000ATEXR1 X

The 'X' placed after the technical file number indicates that the product is subject to specific conditions of use as follows:

1. The maximum surface temperature depends entirely on the operating conditions and not the equipment itself. The combination of the maximum ambient and the maximum process medium temperature shall be used to determine the maximum surface temperature and corresponding temperature classification, considering the safety margins described prescribed in EN ISO 80079-36:2016, Clause 8.2. Additionally, the system designer and users must take precautions to prevent rapid system pressurization which may raise the surface temperature of system components and tubing due to adiabatic compression of the system gas. Furthermore, the Joule-Thomson effect may cause process gases to rise in temperature as they expand going through a regulator. This could raise the external surface temperature of the regulator body and the downstream piping creating a potential source of ignition. Whether the Joule-Thomson effect leads to heating or cooling of the process gas depends on the process gas and the inlet and outlet pressures. The system designer is responsible for determining whether the process gas temperature may raise under any operating conditions.
2. Where the process medium is a liquid or semi-solid material with a surface resistance in excess of $1G\Omega$, special precautions shall be taken to ensure the process does not generate electrostatic discharge.
3. Special consideration shall be made regarding the filtration of the process medium if there is a potential for the process medium to contain solid particles. Where particles are present, the process flow shall be $<1\text{m/s}$ ($<3.3\text{ ft/s}$) in order to prevent friction between the process medium and internal surfaces.
4. Effective earthing (grounding) of the product shall be ensured during installation.
5. The valve body/housing shall be regularly cleaned to prevent build up of dust deposits.
6. Regulators must be ordered with the non-relieving option (instead of the self-relieving option) if the process gas they are to be used with is hazardous (flammable, toxic, etc.). The self-relieving option vents process gas through the regulator cap directly into the atmosphere while the non-relieving option does not. Using regulators with the self-relieving option in a flammable gas system could create an explosive atmosphere in the vicinity of the regulator.
7. Tied diaphragm regulators with outlet ranges greater than 7 barg (100 psig) should be preset to minimize the risk that improper operation might lead to an outboard leak and a potentially explosive atmosphere.
8. All equipment must only be fitted with manufacturer's original spare parts.
9. Ensure that only non-sparking tools are used, as per EN 1127-1, Annex A.

	PRODUCT
REGULATORS	31-B, 31-N
	1164, 1164(OPT-45)
	1171, 1171(OPT-45), 1171(CRYO)
	2171, 2171(OPT-45), 2171(CRYO), 3171
	1465, 3381, 3381(OPT-45), 3381(OPT-40)
	4381, 4381(OPT-37), 4381(CRYO), 4381(OPT-45), 5381
	MPRV-H, MPRV-L
	PBE, PBE-L, PBE-H
	CA-1, CA-2
	CA1, SA1, CA4, SA4, CA5, SA5
	DA2, DA4, DA5, DA6, DA8
	DA0, DA1, DAP, SAP
	SLR-1, SLR-2, PTR-1
	ALR-1, ULR-1, PGR-1
	BQ, BQ(OPT-45), BQ(CRYO)
	123, 123(CRYO), 123(OPT-45), 123(OPT-46G)
	123-1+6, 123-1+6(OPT-45), 123-1+6(OPT-46G), 123-1+6+S, 123-1+6+S(OPT-40)
	1000HP, 1000HP(OPT-37), 1000HP(OPT-45), 1000HP(OPT-45G), 1000HP(CRYO)
	1000HP-1+6, 1000HP-1+8, 1000LP, 1000LP(OPT-45), 1000LP(OPT-46G)
	6987
	8310HP, 8310HP-1+6, 8310HP-1+8, 8310LP, 8311HP, 8311LP
	345, 345(OPT-45)
	BA1/BL1, PA1/PL1
	C-BPV, C-PRV, C-CS
	D, D(CRYO), D(OPT-37), D(OPT-20), D(OPT-45)
	DL, DL(LCC), DL(OPT-45)
	BR, BR(CRYO)
	HP, HP(LCC), HP(OPT-45), HP(OPT46G), HP-1+6+S(OPT-40), HP-1+6+S
	P1, P2, P3, P4, P5, P7
	B2, B7
	POSR-1, POSR-2
	5200P, 5300P
	135
NW-PL, NW-SO	
CG-PILOT	
FG1	
CONTROL VALVES	RANGER, 987, PREMIER
	964, 521, 988, 988-MB, 989
	2296/2296HF
	SCV-30, SCV-S
	FL800/FL200
TANK BLANKETING	8700, 8910, 8920, 8930, 8940
	2100, 2199
	3100, 3200, 3300, 3400, 3500, 3600, 3700
	1078, 1088, 1100, 1049
	5100, 5200, 5400, 5500
	4100, 4200, 4300, 4400, 4500, 4600
MISC	764P/PD, 764-37, 764T

Cashco, Inc.
P.O. Box 6
Ellsworth, KS 67439-0006
PH (785) 472-4461
Fax. # (785) 472-3539
www.cashco.com
email: sales@cashco.com
Printed in U.S.A. 3700-IOM

Cashco GmbH
Handwerkerstrasse 15
15366 Hoppegarten, Germany
PH +49 3342 30968 0
Fax. No. +49 3342 30968 29
www.cashco.com
email: germany@cashco.com

Cashco do Brasil, Ltda.
Rua Bonifácio Cubas, 389.
Cep 02731-000 – Vila Albertina - São Paulo - SP
PH +55 11 99677 7177
Fax. No.
www.cashco.com
email: brazil@cashco.com