



Model 2100

Gauge Hatch

Valve Concepts, Inc.
ISO Registered Company

SECTION I

I. DESIGN AND FUNCTION

Model 2100 is primarily designed to provide easy access into storage tanks for gauging and obtaining samples. May also provide additional pressure relief as a supplement for normal or emergency venting. Available with either a non-locking or locking hatch.

LATCH DESIGNS
No Latch - (Non Locking)
Knob Latch - (Locking)

SECTION II

II. INSPECTION AND STORAGE:

The gauge hatch is carefully packaged to prevent damage or contamination during shipping. Inspect the equipment when it is received and report any damage to the carrier immediately. The gauge hatch should be stored with all protective covers in place.

SECTION III

III. INSTALLATION

 WARNING
The gauge hatch must be installed in a horizontal position. The tank nozzle on which the hatch is mounted should have the same nominal diameter as the gauge hatch. It is recommended that the tank nozzle flange face be within 1 degree of horizontal. Minimum clearance between tank roof and face of the hatch flange must be at least equal to the valves' nominal flange bore. Tank nozzle bore must be greater than or equal to flange bore.

The Model 2100 Gauge Hatch is designed to mate with a 150 lb ASME flange. Torque guidelines are provided in Table 1.

Before installing the 2100 Gauge Hatch remove all packing materials.

Inspect the gasket seating surface of the tank nozzle flange. It must be clean, free of scratches, corrosion, tool marks and flat.

Gauge hatches are furnished with flat faced flanges. It is recommended that they be installed on mating flat face flanges with a full faced gasket. If the flat face of the hatch is sealing against a raised face steel flange, a spacer or filler ring must be used to fill the annular space of the raised face steel flange.

Make sure the gasket is suitable for the application and is in good condition. For full face gaskets, we recommend the use of a 1/8-inch Expanded PTFE gasket.

Center the gasket within the bolt circle of the tank flange and carefully set the gauge hatch on the flange nozzle and align the bolt holes.

All stud threads must be lubricated to obtain proper torque results. A washer should be used under each stud nut.

Install the studs, washers and nuts and tighten nuts hand tight. Check proper alignment of flange faces. Misalignment of flange faces will cause bending stresses at the flange and flange joint and damage may result. Correct any misalignment prior to applying torque to nuts.

TABLE 1
All Torque Requirements Are Dependant On Gasket Material
Bolt Torque Specifications - ASME #150 Flange Connections

MOUNTING FLANGE	BOLT TORQUE - ft. * lbs.	NUMBER BOLTS TOTAL	STUD SPECIFICATIONS
	FLAT FACE		THREAD UNC
4"	78	8	5/8" - 11
6"	150	8	3/4" - 10
8"	228	8	3/4" - 10
10"	246	12	7/8" - 9
12"	348	12	7/8" - 9

All nuts must be torqued in proper sequence and equal increments. Proceed through the tightening sequence until the recommended torque is attained.

Recheck the torque on each bolt in the same sequence as bolts previously tightened may have relaxed through the torque sequence.

SECTION IV

IV. MAINTENANCE - Replace Diaphragm

Maintenance procedures hereinafter are based upon removal of the gauge hatch from the tank flange.

 CAUTION
DO NOT attempt to remove a locked gauge hatch from a tank or process vessel without first bleeding all pressure from the system.

Hatch with Locking Feature:

Knob Latch: Rotate knob (19) CCW slowly several revolutions to allow eye bolt (12) and washer (17) to slide out and dis-engage from the hinge arm assembly (2).

All Hatches:

Remove cotter pin and washer (35) from arm pin (9). Slide arm pin (9) out of flange base (1). Lift arm (2) and pallet (30) sub-assembly up to remove and place on work surface.

Gauge Hatch without Weights: Flip arm/pallet (2,3) sub-assembly over and secure center bolt (20) in a vice. Remove the "S" hook (33) from center bolt (20). Rotate pallet nut (24) CCW and remove nut, lock washer (23), flat washer (22) and diaphragm retainer (5).

Gauge Hatch with Weights: Flip arm/pallet (2,3) sub-assembly over and secure center bolt nut (25) in a vice. Remove the "S" hook (33) from center bolt (20). Rotate nut (24) CCW to remove nut (24), lock washer (23) and flat washer (22).

Remove diaphragm retainer plate (5) and diaphragm (4).

Clean and inspect pallet (3) seating surface.

Apply TFE paste around the hole in the pallet (3).

Install new diaphragm (4) in recess of the pallet (3). Re-install diaphragm retainer plate (5), flat washer (22), lock washer (23) and nut (24). Torque nut to 20 ft-lbs.

Re-insert "S" hook (33) into the hole in the center bolt (20). Use pliers to close the end of the "S" hook and secure it so it can not be easily removed from the center bolt (20).

Flip arm/pallet (2,3) sub-assembly over and re-install the whole pallet (3) /hinge arm assembly (2) on to the flange base assembly (1). Align the pin holes and insert the pivot pin (9), washer (35) and cotter pin (15). Turn back the ends of the cotter pin to secure.

Raise and lower arm/pallet (2,3) assembly to confirm that diaphragm (4) rest evenly on the seating surface of the flange base (1).

If hatch includes a locking feature, engage eye bolt (12) and washer (17) over groove in the hinge arm (2) and secure in place.

Return to Section III for Installation.

SECTION V

V. ORDERING INFORMATION

NEW REPLACEMENT UNIT vs PARTS "KIT" FOR FIELD REPAIR

To obtain a quotation or place an order, please retrieve the Serial Number and Product Code that was stamped on the metal name plate and attached to the unit. This information can also be found on the Bill of Material ("BOM"), a parts list that was provided when unit was originally shipped. (Serial Number typically 6 digits).

NEW REPLACEMENT UNIT:

Contact your local Cashco, Inc., Sales Representative with the Serial Number, Product code and the pressure setting. With this information they can provide a quotation for a new unit including a complete description, price and availability.



CAUTION

Do not attempt to alter the original construction of any unit without assistance and approval from the factory. All purposed changes will require a new name plate with appropriate ratings and new product code to accommodate the recommended part(s) changes.

PARTS "KIT" for FIELD REPAIR:

Contact your local Cashco, Inc., Sales Representative with the Serial Number and Product code. Identify the parts and the quantity required to repair the unit from the "BOM" sheet that was provided when unit was originally shipped.

NOTE: *Those part numbers that have a quantity indicated under "Spare Parts" in column "A" reflect minimum parts required for inspection and rebuild, - "Soft Goods Kit". Those in column "B" include minimum trim replacement parts needed plus those "Soft Goods" parts from column "A".*

If the "BOM" is not available, refer to the cross-sectional drawings included in this manual for part identification and selection.

A Local Sales Representative will provide quotation for appropriate Kit Number, Price and Availability.

The contents of this publication are presented for informational purposes only, and while every effort has been made to ensure their accuracy, they are not to be construed as warranties or guarantees, express or implied, regarding the products or services described herein or their use or applicability. We reserve the right to modify or improve the designs or specifications of such product at any time without notice. Cashco, Inc. does not assume responsibility for the selection, use or maintenance of any product. Responsibility for proper selection, use and maintenance of any Cashco, Inc. product remains solely with the purchaser.

MODEL 2100

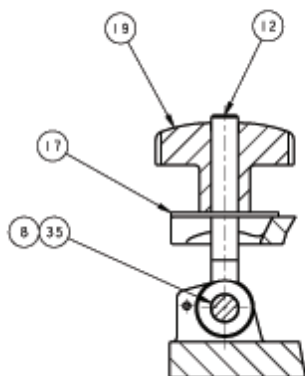

Knob Latch

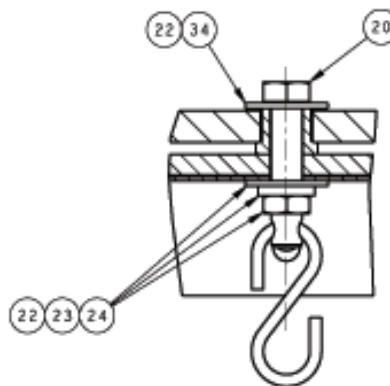

**Center Bolt
No Weights**

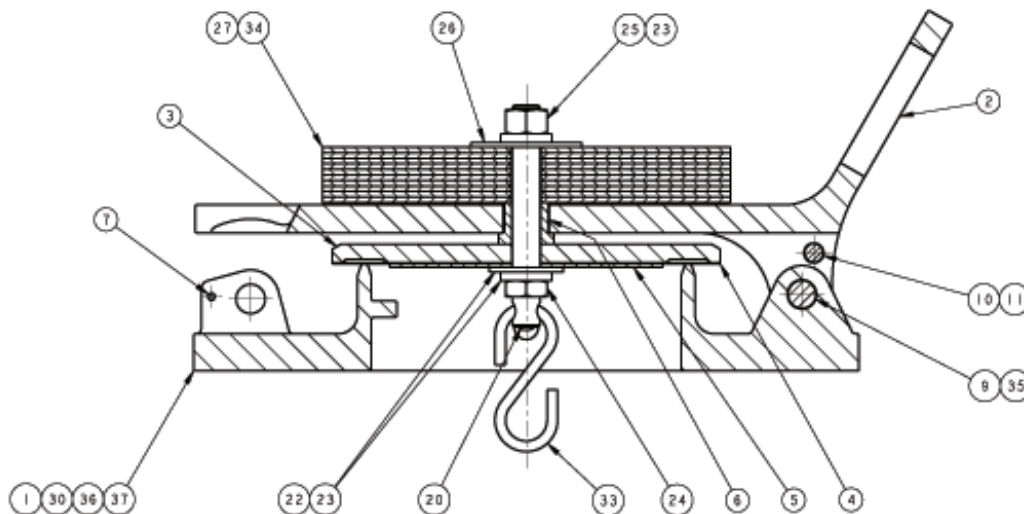

**No Latch
Center Bolt with Weights**

PART LIST

ITEM NO.	Description	ITEM NO.	Description	ITEM NO.	Description
1	Flange	10	Arm Stop	25	Weight Nut
2	Hinge Arm	11	Stop Nut	26	Weight Retainer
3	Pallet	12	Eye Bolt	27	Weight
4	Diaphragm ‡	17	Washer	33	S-Hook
5	Diaphragm Retainer	19	Knob	34	Swivel GrD Washer
6	Pallet Swivel	20	Center Bolt	35	Pivot Grd Washer
7	Latch Stop Pin	22	Flat Washer	36	Name Plate
8	Latch Pivot Pin	23	Lock Washer		
9	Arm Pivot Pin	24	Pallet Nut		

‡ Recommended replacement parts.

Cashco, Inc.
P.O. Box 6
Ellsworth, KS 67439-0006
PH (785) 472-4461
Fax. # (785) 472-3539
www.cashco.com
email: sales@cashco.com
Printed in U.S.A. 2100-IOM

Cashco GmbH
Handwerkerstrasse 15
15366 Hoppegarten, Germany
PH +49 3342 30968 0
Fax. No. +49 3342 30968 29
www.cashco.com
email: germany@cashco.com

Cashco do Brasil, Ltda.
Al.Venus, 340
Indaiatuba - Sao Paulo, Brazil
PH +55 11 99677 7177
Fax. No.
www.cashco.com
email: brazil@cashco.com

ATEX 2014/34/EU: Explosive Atmospheres and Cashco Inc. Products



Cashco, Inc. declares that the products listed in the table below has been found to comply with the Essential Health and Safety Requirements relating to the design and construction of products intended for use in potentially explosive atmospheres given in Annex II of the ATEX Directive 2014/34/EU. Compliance with the Essential Health and Safety Requirements has been assured by compliance with EN ISO 80079-36:2016 and EN ISO 80079-37:2016. The product will be marked as follows:

CE  II 2 G
Ex h IIB T6... T1 Gb
1000ATEXR1 X

The 'X' placed after the technical file number indicates that the product is subject to specific conditions of use as follows:

1. The maximum surface temperature depends entirely on the operating conditions and not the equipment itself. The combination of the maximum ambient and the maximum process medium temperature shall be used to determine the maximum surface temperature and corresponding temperature classification, considering the safety margins described prescribed in EN ISO 80079-36:2016, Clause 8.2. Additionally, the system designer and users must take precautions to prevent rapid system pressurization which may raise the surface temperature of system components and tubing due to adiabatic compression of the system gas. Furthermore, the Joule-Thomson effect may cause process gases to rise in temperature as they expand going through a regulator. This could raise the external surface temperature of the regulator body and the downstream piping creating a potential source of ignition. Whether the Joule-Thomson effect leads to heating or cooling of the process gas depends on the process gas and the inlet and outlet pressures. The system designer is responsible for determining whether the process gas temperature may raise under any operating conditions.
2. Where the process medium is a liquid or semi-solid material with a surface resistance in excess of 1GΩ, special precautions shall be taken to ensure the process does not generate electrostatic discharge.
3. Special consideration shall be made regarding the filtration of the process medium if there is a potential for the process medium to contain solid particles. Where particles are present, the process flow shall be <1m/s (<3.3 ft/s) in order to prevent friction between the process medium and internal surfaces.
4. Effective earthing (grounding) of the product shall be ensured during installation.
5. The valve body/housing shall be regularly cleaned to prevent build up of dust deposits.
6. Regulators must be ordered with the non-relieving option (instead of the self-relieving option) if the process gas they are to be used with is hazardous (flammable, toxic, etc.). The self-relieving option vents process gas through the regulator cap directly into the atmosphere while the non-relieving option does not. Using regulators with the self-relieving option in a flammable gas system could create an explosive atmosphere in the vicinity of the regulator.
7. Tied diaphragm regulators with outlet ranges greater than 7 barg (100 psig) should be preset to minimize the risk that improper operation might lead to an outboard leak and a potentially explosive atmosphere.
8. All equipment must only be fitted with manufacturer's original spare parts.
9. Ensure that only non-sparking tools are used, as per EN 1127-1, Annex A.

	PRODUCT
REGULATORS	31-B, 31-N
	1164, 1164(OPT-45)
	1171, 1171(OPT-45), 1171(CRYO)
	2171, 2171(OPT-45), 2171(CRYO), 3171
	1465, 3381, 3381(OPT-45), 3381(OPT-40)
	4381, 4381(OPT-37), 4381(CRYO), 4381(OPT-45), 5381
	MPRV-H, MPRV-L
	PBE, PBE-L, PBE-H
	CA-1, CA-2
	CA1, SA1, CA4, SA4, CA5, SA5
	DA2, DA4, DA5, DA6, DA8
	DA0, DA1, DAP, SAP
	SLR-1, SLR-2, PTR-1
	ALR-1, ULR-1, PGR-1
	BQ, BQ(OPT-45), BQ(CRYO)
	123, 123(CRYO), 123(OPT-45), 123(OPT-46G)
	123-1+6, 123-1+6(OPT-45), 123-1+6(OPT-46G), 123-1+6+S, 123-1+6+S(OPT-40)
	1000HP, 1000HP(OPT-37), 1000HP(OPT-45), 1000HP(OPT-45G), 1000HP(CRYO)
	1000HP-1+6, 1000HP-1+8, 1000LP, 1000LP(OPT-45), 1000LP(OPT-46G)
	6987
	8310HP, 8310HP-1+6, 8310HP-1+8, 8310LP, 8311HP, 8311LP
	345, 345(OPT-45)
	BA1/BL1, PA1/PL1
	C-BPV, C-PRV, C-CS
	D, D(CRYO), D(OPT-37), D(OPT-20), D(OPT-45)
	DL, DL(LCC), DL(OPT-45)
	BR, BR(CRYO)
	HP, HP(LCC), HP(OPT-45), HP(OPT46G), HP-1+6+S(OPT-40), HP-1+6+S
	P1, P2, P3, P4, P5, P7
	B2, B7
	POSR-1, POSR-2
	5200P, 5300P
135	
NW-PL, NW-SO	
CG-PILOT	
FG1	
CONTROL VALVES	RANGER, 987, PREMIER
	964, 521, 988, 988-MB, 989
	2296/2296HF
	SCV-30, SCV-S
	FL800/FL200
TANK BLANKETING	8700, 8910, 8920, 8930, 8940
	2100, 2199
	3100, 3200, 3300, 3400, 3500, 3600, 3700
	1078, 1088, 1100, 1049
	5100, 5200, 5400, 5500
	4100, 4200, 4300, 4400, 4500, 4600
MISC	764P/PD, 764-37, 764T