



# MODEL 1000HP-5 and MODEL 1000HP-36

## CRYOGENIC PRESSURE REDUCING REGULATORS



Model 1000HP-5

Model 1000HP-5 and 1000HP-36 are cryogenic reducing regulators used primarily in handling liquified industrial gases. The Opt-5 construction is essentially of bronze and brass materials; Opt-36 is of austenitic stainless steel materials.

The design takes advantage of all the features of the basic 1000HP reducing regulator; see Technical Bulletin 1000HP-BASIC-TB. The availability of optional construction and body and trim materials is limited to those indicated herein.

The straight-thru flow path inherent in the 1000HP design allows for higher capacity. The streamlined path also reduces wear and maintenance for the flashing or cavitating conditions frequently associated with cryogenic service.

### APPLICATIONS

Widely applied in pressure building service for remote liquid storage tanks for industrial gases (see Figure 1). Also used in distribution piping systems where there is the possibility of exposure to temperatures below  $-20^{\circ}\text{F}$  ( $-29^{\circ}\text{C}$ ), and where higher flow capacity is required.

## PRINCIPLES OF OPERATION

Reference Technical Bulletin 1000HP-BASIC-TB for the explanation of the design principles of the basic valve. Advantages due to all those principles indicated also apply to a 1000HP-CRYO regulator. The major difference

between the 1000HP-BASIC and 1000HP-CRYO is the different materials required for the cryogenic temperature range of -325 to +150°F (-198 to +66°C).

### STANDARD/GENERAL SPECIFICATIONS

**Body Sizes:** 1/2", 3/4", 1", 1-1/2" and 2";  
(DN15, 20, 25, 40 and 50).

**End Connections:** Standard – NPT female.

**Body/Spring Chamber/Cylinder Material Combinations:** Standard – BRZ/BRZ/BRZ and SST/SST/SST.  
Special - CS/CS/SST

BRZ = Cast bronze  
SST = Cast stainless steel  
CS = Cast steel  
See Table 4 for material specifications.

**Trim Designs:** Composition seat (see Figure 1) or Metal seat (see Figure 3). Metal diaphragms ONLY.

Available in three trim material combinations only. See Table 5 for materials.

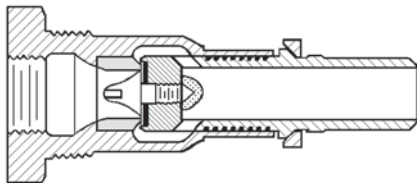

**Figure 1: Composition Seat**

**Maximum Inlet Pressure:** Dependent only on cylinder material. (See Table 3):

**NOTE:** 1000HP is a flow-to-open (FTO) design; this places an upper limitation on inlet pressure for a given outlet pressure setting.

**Temperature Range:** -325° to +150°F (-198° to +66°C). Exception: CS body and spring chamber material -50° to +150°F (-46° to +66°C). See Table 4.

**Outlet Pressure Range:** See Table 1 for individual range spring span.

Body Size		Full Range		Number of Range Springs
In	(DN)	psig	(Barg)	
1/2"	(15)	10–300	(.69–20.7)	5
3/4"	(20)			6
1"	(25)	10–250	(.69–17.2)	6
1-1/2"	(40)	10–150	(.69–10.3)	3
2"	(50)	10–90	(.69–6.2)	3

**Maximum Pressure Drop:** **NOTE:** 1000HP is a flow-to-open (FTO) design; this places a lower limitation on outlet pressure setting for some inlet pressure levels.

Metal Seated Design:

“S1” trim designation – up to 650 psid (44.8 Bard).

Composition Seat Designs:

“B5” trim designation – up to 390 psid (26.9 Bard).

“S36” trim designation – up to 650 psid (44.8 Bard).

**Minimum**

**Pressure Drop:** Opt-5: 1 psid (0.07 Bard).  
Opt-36: 5 psid (0.34 Bard).  
Opt-17+36: 1 psid (0.07 Bard).

**Seat Leakage:**

Meets ANSI/FCI 70-2.  
Metal Seated – Class IV.  
Composition Seat – Class VI.

See Tables 6 and 7 for flow capacity expressed in Cv’s for full port and 1-step reduced port (Opt-12).

See Table 2 for “Wide Open Cv”; use for sizing of safety relief device.

**Range Springs:** Standard: SST.

**Diaphragm Flange Bolting:** Standard: SST.

**Gaskets:** Standard: TFE/Silicate.  
Suitable for oxygen service.

**Standard Cleaning:** BRZ and SST units are cleaned per Cashco Spec. #S-1134.  
See Option - 55.

**Painting:** BRZ and SST units are not painted.  
CS units - All non-corrosion resistant portions to be painted with epoxy paint per Cashco Spec #S-1606.

## OPTION SPECIFICATIONS

**Option -5:** BRASS/BRONZE CRYOGENIC CONSTRUCTION. BRZ/BRZ/BR body/spring chamber/cylinder materials. Only B5 trim designation number available. Includes Opt-14 integral seat ring, Opt-17 piston spring, Opt-25 tapped spring chamber vent, 1/8" (DN6) drain hole, and Opt-55, cleaning for oxygen service.

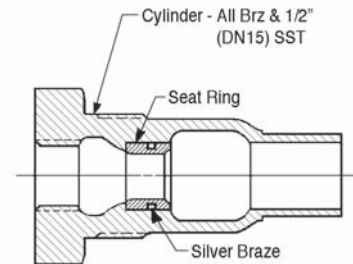

**Option -12:** REDUCED PORT ORIFICE. Use when high inlet pressure negates use of the standard full port orifice. Also used when oversized body is desired to accommodate piping size. Available in metal seat or composition seat materials, in all trim designations, and in all body sizes. See Table 7 for flow capacity in Cvs.

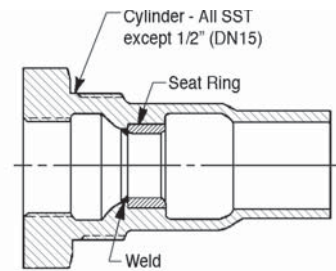

**Option -14:** INTEGRAL SEAT. Standard for B5 trim designation no., full or Opt-12 reduced port; optional for S1 or S36 trim designation numbers. Pressed-in seat ring-to-cylinder joint is sealed as a path of leakage by brazing or welding. The procedure also serves as a permanent joint for flow conditions where service conditions are "severe", subject to vibration, or thermal cycling.

**Figure 2: Opt-14 Integral Seat**

less than 5 psid (.34 Bard). Minimizes plug/cylinder frictional effects. 302 SST material only.

Seat ring is silver brazed to cylinder for "B5" series trim designation, and to 1/2" (DN15) body size cylinders with "S\_" series trim designations. For all other body sizes with "S\_" series designations the seat ring is welded to the cylinder.

**Option -25 (Std):** TAPPED VENT. Primary use as location to inject purge gas to prevent ice buildup within spring chamber. 1/4" (DN8) NPT.

Recommended for all hydrogen or helium applications. Recommended when pressure drop exceeds 300 psid (20.7 Bard). Required when pressure drop exceeds 450 psid (31.0 Bard).

**Option -26:** PRESSURE TAP. 1/4" (DN8) NPT drain tap with plug in body top side registering outlet - P<sub>2</sub> - pressure. Recommended for downstream piping pressure sensing. Plug material similar to body material. Recommended for flashing or cavitating liquids.

**Option -17:** PISTON SPRING. Standard for B5 trim designation; optional for S1 or S36 trim designations. Required for applications where pressure drop is

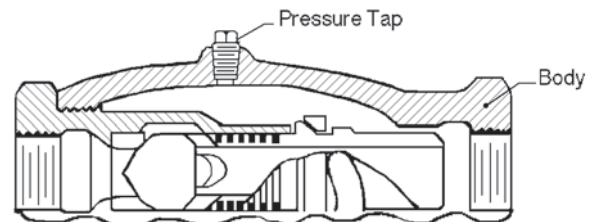

**Figure 3: Opt-26 Pressure Tap, Metal Seat**

**Option -36:** SSTCRYOGENICCONSTRUCTION. SST/SST/SST body/spring chamber/cylinder materials. Only S1 or S36 trim designation numbers. Includes Opt-25 tapped spring chamber vent, 1/8" (DN6) drain hole, and Opt-55 cleaning for oxygen service.

**Option -55:** SPECIAL CLEANING. BRZ or SST body materials ONLY Cleaning per Cashco Spec #S-1134. Acceptable cleaning level for Oxygen gas Service. **NOTE:** Design Pressure Rating shall not exceed 375 psig (25.8 Barg) when body material is SST and process medium is oxygen.

**Option -40:** CS NACE CONSTRUCTION. Internal wetted portions meet NACE standard MR0175, when the exterior of the regulator is not directly exposed to a sour gas environment, buried, insulated or otherwise denied direct atmospheric exposure. CS/CS (LCC) body/spring chamber material with S40B, S40C trim only. Available all sizes. Opt-30 requires post-weld stress relieving by heat treating. Not available with Opt-14 or Opt-17.

### TECHNICAL SPECIFICATIONS

TABLE 1  
RANGE SPRINGS – SST

Body Size		Standard – SST	
In.	(DN)	psig	(Barg)
1/2"	(15)	10–50	(.69–3.4)
		40–80	(2.7–5.5)
		65–100	(4.5–6.9)
		80–150	(5.5–10.3)
		120–300	(8.3–20.7)
3/4"	(20)	10–40	(.69–2.7)
		30–60	(2.1–4.1)
		50–70	(3.4–4.8)
		55–110	(3.8–7.6)
		90–150	(6.2–10.3)
		120–300	(8.3–20.7)
1"	(25)	10–30	(.69–2.1)
		25–45	(1.7–3.1)
		35–50	(2.4–3.4)
		40–80	(2.7–5.5)
		65–150	(4.5–10.3)
		120–250	(8.3–17.2)
1-1/2"	(40)	10–50	(.69–3.4)
		40–75	(2.7–5.2)
		60–150	(4.1–10.3)
2"	(50)	10–30	(.69–2.1)
		25–45	(1.7–3.1)
		35–90	(2.4–6.2)

TABLE 2  
MAXIMUM CAPACITY – Cv  
FOR SIZING SAFETY RELIEF DEVICE -  
(WITH PLUG WIDE OPEN)

Body Size		Orifice Size	
In.	(DN)	Standard (Full)	Opt-12 (Reduced Port)
1/2"	(15)	5	3
3/4"	(20)	9	7
1"	(25)	9	8
1-1/2"	(40)	17	13
2"	(50)	22	20

**NOTE:** See Table 3. Indicated outlet pressure limits are those to contain overpressure conditions; such overpressure may cause internal damage. It is recommended that pressure safety devices – safety relief valve or rupture disc – have their setpoint relief pressures at 110% of the UVRS (UVRS = "Upper Value of Range Spring"). **Example:** For a 90–150 psig (6.2–10.3 Barg) range spring, the safety devices should be set to relieve at 110% x 150 psig = 165 psig (11.4 Barg).

**TABLE 3**  
**MAXIMUM ALLOWABLE PRESSURE vs. TEMPERATURE;**  
**FOR PRESSURE CONTAINMENT OF**  
**BODY, SPRING CHAMBER AND CYLINDER**  
(See Table 4 for Material Specifications)

Materials of Construction <sup>1</sup>	Inlet – Cylinder				Outlet – Body & Spring Chamber			
	Pressure		Temperature		Pressure		Temperature	
	psig	(Barg)	°F	(°C)	psig	(Barg)	°F	(°C)
BRZ / BRZ / BR	400	(27.6)	-325 to +150	(-198 to +66)	400	(27.6)	-325 to +150	(-198 to +66)
SST / SST / SST	740	(51.0)	-325 to +150	(-198 to +66)	400	(27.6)	-325 to +150	(-198 to +66)
CS / CS / SST (See TABLE 4)	740	(51.0)	-50 to + 150	(-46 to + 66)	400	(27.6)	-50 to +150	(-46 to +66)

<sup>1</sup> For constructions containing following materials as the body, spring chamber, or cylinder, the pressure vs. temperature limits are based upon lower temperature limits as allowed by ANSI B31.3.

**TABLE 4**  
**MATERIAL SPECIFICATIONS OF**  
**BODY, SPRING CHAMBER AND CYLINDER**

Material	ASTM Specifications
BRZ – cast bronze	B62, Alloy 83600; 85% Cu, 5% Sn, 5% Pb, 5% Zn
SST – cast stainless steel	A351, Gr. CF8M (cast 316 SST)
CS – cast steel (LCC)	ASTM A352 Gr. LCC

**TABLE 5**  
**TRIM MATERIAL COMBINATIONS**

Part	Trim Designation Nos.				
	Brass Trim #	SST Trim #			
	B5	S1	S40B (NACE)	S36	S40C (NACE)
Diaphragm	Phos. Bronze	302 SST	BC **	302 SST	BC **
Cylinder	Brass	CF8M	CF8M	CF8M	CF8M
Valve Seat	Brass	316 SST	316 SST	316 SST	316 SST
Plug	Brass	316 SST	316 SST	316 SST	316 SST
Seat Disc	TFE	None (Metal)	None (Metal)	TFE	TFE
Seat Disc Screw	Brass	None	None	316 SST	316 SST
Plug Collar	Brass	316 SST	316 SST	316 SST	316 SST
Rocker Arm Shaft	Brass	316 SST	316 SST	316 SST	316 SST
Rocker Arm	*	CF8M	CF8M	CF8M	CF8M
Pusher Plate Stud	Brass	CF8M	CF8M	CF8M	CF8M
Pusher Plate	Bronze	CF8M	CF8M	CF8M	CF8M
Stud Collar	Brass	316 SST	316 SST	316 SST	316 SST
Cotter Pin	Brass	316 SST	316 SST	316 SST	316 SST
Nut	Brass	316 SST	316 SST	316 SST	316 SST

\* Sizes 1/2" - 1" = SST CF8M      Sizes 1-1/2" & 2" = Bronze  
\*\* Special BC Material for Low Temperature down to -50°F (-46°C).

**NOTE:** Cashco does not recommend metal seated trim on any service flow that will dead end down stream of the pressure reducing regulator.

TABLE 6  
Cv – FLOW CAPACITY

**FULL PORT – METAL DIAPHRAGM**

Based on 400 psid (27.6 Bard) max pressure drop limit for composition seat, and on 650 psid (44.8 Bard) for metal seat.

$$(F_L = 0.93)$$

METAL DIAPHRAGM – SIZE – 1/2" (DN15) – FULL PORT										
Outlet Pressure		Max Inlet Pressure				Cv @ % DROOP			Range Spring	
		Metal Seated		Composition Seated						
psig	(Barg)	psig	(Barg)	psig	(Barg)	10%	20%	30%	psig	(Barg)
10	(.69)	215	(14.8)	215	(14.8)	0.42	0.81	1.18	10–50	(.69–3.4)
15	(1.0)	335	(23.1)	335	(23.1)	0.47	0.89	1.27	10–50	(.69–3.4)
20	(1.4)	450	(31.0)	420	(29.0)	0.53	0.98	1.37	10–50	(.69–3.4)
25	(1.7)	570	(39.3)	425	(29.3)	0.58	1.04	1.45	10–50	(.69–3.4)
35	(2.4)	685	(47.2)	435	(30.0)	0.67	1.18	1.62	10–50	(.69–3.4)
50	(3.4)	740	(51.0)	450	(31.0)	0.88	1.52	2.01	40–80	(2.8–5.5)
75	(5.2)	740	(51.0)	475	(32.8)	1.03	1.78	2.34	65–100	(4.5–6.9)
100	(6.9)	740	(51.0)	500	(34.5)	1.59	2.58	3.50	80–150	(5.5–10.3)
125	(8.6)	740	(51.0)	525	(36.2)	1.72	2.69	3.50	80–150	(5.5–10.3)
150	(10.3)	740	(51.0)	550	(37.9)	1.40	2.48	3.40	120–300	(8.3–20.7)
175	(12.1)	740	(51.0)	575	(39.7)	1.49	2.56	3.50	120–300	(8.3–20.7)
200	(13.8)	740	(51.0)	600	(41.4)	1.58	2.64	3.50	120–300	(8.3–20.7)
250	(17.2)	740	(51.0)	650	(44.8)	1.67	2.72	3.50	120–300	(8.3–20.7)
300	(20.7)	740	(51.0)	700	(48.3)	1.77	2.88	3.50	120–300	(8.3–20.7)

METAL DIAPHRAGM – SIZE – 3/4" (DN20) – FULL PORT										
Outlet Pressure		Max Inlet Pressure				Cv @ % DROOP			Range Spring	
		Metal Seated		Composition Seated						
psig	(Barg)	psig	(Barg)	psig	(Barg)	10%	20%	30%	psig	(Barg)
10	(.69)	160	(11.0)	160	(11.0)	0.70	1.36	2.07	10–40	(.69–2.8)
15	(1.0)	250	(17.2)	250	(17.2)	0.76	1.50	2.20	10–40	(.69–2.8)
20	(1.4)	340	(23.4)	340	(23.4)	0.82	1.65	2.34	10–40	(.69–2.8)
25	(1.7)	425	(29.3)	425	(29.3)	0.88	1.77	2.44	10–40	(.69–2.8)
35	(2.4)	580	(40.0)	435	(30.0)	1.00	2.01	2.65	30–60	(2.1–4.1)
50	(3.4)	700	(48.3)	450	(31.0)	1.33	2.66	3.47	30–60	(2.1–4.1)
75	(5.2)	740	(51.0)	475	(32.8)	1.93	3.32	4.43	55–110	(3.8–7.6)
100	(6.9)	740	(51.0)	500	(34.5)	2.56	4.18	5.00	55–110	(3.8–7.6)
125	(8.6)	740	(51.0)	525	(36.2)	2.43	4.00	5.00	90–150	(6.2–10.3)
150	(10.3)	740	(51.0)	550	(37.9)	1.66	3.03	4.08	120–300	(8.3–20.7)
175	(12.1)	740	(51.0)	575	(39.7)	1.72	3.07	4.14	120–300	(8.3–20.7)
200	(13.8)	740	(51.0)	600	(41.4)	1.80	3.13	4.20	120–300	(8.3–20.7)
250	(17.2)	740	(51.0)	650	(44.8)	2.00	3.38	4.67	120–300	(8.3–20.7)
300	(20.7)	740	(51.0)	700	(48.3)	2.18	3.63	5.00	120–300	(8.3–20.7)

METRIC CONVERSION FACTOR: Cv ÷ 1.16 = kv

TABLE 6  
Cv – FLOW CAPACITY

**FULL PORT – METAL DIAPHRAGM**

Based on 400 psid (27.6 Bard) max pressure drop limit for composition seat, and on 650 psid (44.8 Bard) for metal seat.

$$(F_L = 0.93)$$

METAL DIAPHRAGM – SIZE – 1" (DN25) – FULL PORT										
Outlet Pressure		Max Inlet Pressure				Cv @ % DROOP			Range Spring	
		Metal Seated		Composition Seated						
psig	(Barg)	psig	(Barg)	psig	(Barg)	10%	20%	30%	psig	(Barg)
10	(.69)	160	(10.0)	145	(10.0)	0.78	1.55	2.42	10–30	(.69–2.1)
15	(1.0)	220	(15.2)	220	(15.2)	0.87	2.10	2.67	10–30	(.69–2.1)
20	(1.4)	300	(20.7)	300	(20.7)	0.96	1.92	2.93	10–30	(.69–2.1)
25	(1.7)	375	(25.9)	375	(25.9)	1.04	2.13	3.13	10–30	(.69–2.1)
35	(2.4)	515	(35.5)	435	(30.0)	1.21	2.54	3.53	25–45	(1.7–3.1)
50	(3.4)	700	(48.3)	450	(31.0)	1.67	3.47	4.62	40–80	(2.8–5.5)
75	(5.2)	740	(51.0)	475	(32.8)	2.25	4.79	6.00	40–80	(2.8–5.5)
100	(6.9)	740	(51.0)	500	(34.5)	3.03	5.20	6.00	65–150	(4.5–10.3)
125	(8.6)	740	(51.0)	525	(36.2)	3.10	5.30	6.00	65–150	(4.5–10.3)
150	(10.3)	740	(51.0)	550	(37.9)	2.88	5.02	6.00	120–250	(8.3–17.2)
175	(12.1)	740	(51.0)	575	(39.7)	2.95	5.11	6.00	120–250	(8.3–17.2)
200	(13.8)	740	(51.0)	600	(41.4)	3.03	5.20	6.00	120–250	(8.3–17.2)
250	(17.2)	740	(51.0)	650	(44.8)	3.18	5.32	6.00	120–250	(8.3–17.2)

METAL DIAPHRAGM – SIZE – 1-1/2" (DN40) – FULL PORT										
Outlet Pressure		Max Inlet Pressure				Cv @ % DROOP			Range Spring	
		Metal Seated		Composition Seated						
psig	(Barg)	psig	(Barg)	psig	(Barg)	10%	20%	30%	psig	(Barg)
10	(.69)	115	(7.9)	115	(7.9)	1.75	3.27	4.82	10–50	(.69–3.4)
15	(1.0)	190	(13.1)	190	(13.1)	2.04	3.79	5.42	10–50	(.69–3.4)
20	(1.4)	260	(17.9)	260	(17.9)	2.33	4.30	6.01	10–50	(.69–3.4)
25	(1.7)	330	(22.8)	330	(22.8)	2.62	4.82	6.61	10–50	(.69–3.4)
35	(2.4)	435	(30.0)	435	(30.0)	3.75	6.53	8.70	10–50	(.69–3.4)
50	(3.4)	635	(43.8)	450	(31.0)	4.15	7.15	9.10	40–75	(2.8–5.2)
75	(5.2)	740	(51.0)	475	(32.8)	5.97	9.32	10.70	60–150	(4.1–10.3)
100	(6.9)	740	(51.0)	500	(34.5)	6.10	9.40	10.75	60–150	(4.1–10.3)
125	(8.6)	740	(51.0)	525	(36.2)	6.23	9.49	10.78	60–150	(4.1–10.3)
150	(10.3)	740	(51.0)	550	(37.9)	6.37	9.58	10.80	60–150	(4.1–10.3)

METRIC CONVERSION FACTOR:  $C_v \div 1.16 = k_v$

TABLE 6  
Cv – FLOW CAPACITY

**FULL PORT – METAL DIAPHRAGM**

Based on 400 psid (27.6 Bard) max pressure drop limit for composition seat, and on 650 psid (44.8 Bard) for metal seat.

$$(F_L = 0.93)$$

METAL DIAPHRAGM – SIZE – 2" (DN50) – FULL PORT										
Outlet Pressure		Max Inlet Pressure				Cv @ % DROOP			Range Spring	
		Metal Seated		Composition Seated						
psig	(Barg)	psig	(Barg)	psig	(Barg)	10%	20%	30%	psig	(Barg)
10	(.69)	165	(11.4)	165	(11.4)	2.10	4.27	6.55	10–30	(.69–2.1)
15	(1.0)	270	(18.6)	270	(18.6)	2.26	4.58	6.90	10–30	(.69–2.1)
20	(1.4)	370	(25.5)	370	(25.5)	2.42	4.90	7.25	10–30	(.69–2.1)
25	(1.7)	470	(32.4)	425	(29.3)	2.59	5.21	7.60	10–30	(.69–2.1)
35	(2.4)	500	(34.5)	435	(30.0)	5.55	9.60	11.30	25–45	(1.7–3.1)
50	(3.4)	700	(48.3)	450	(31.0)	6.85	10.35	12.00	35–90	(2.4–6.2)
75	(5.2)	740	(51.0)	475	(32.8)	5.87	9.70	11.40	35–90	(2.4–6.2)
90	(6.2)	740	(51.0)	500	(34.5)	6.48	10.03	11.73	35–90	(2.4–6.2)

TABLE 7  
Cv – FLOW CAPACITY

**OPT -12, 1-STEP REDUCED PORT – METAL DIAPHRAGM**

Based on 400 psid (27.6 Bard) max pressure drop limit for composition seat, and on 650 psid (44.8 Bard) for metal seat.

$$(F_L = 0.93)$$

METAL DIAPHRAGM – SIZE – 1/2" (DN15) – 1-STEP REDUCED PORT										
Outlet Pressure		Max Inlet Pressure				Cv @ % DROOP			Range Spring	
		Metal Seated		Composition Seated						
psig	(Barg)	psig	(Barg)	psig	(Barg)	10%	20%	30%	psig	(Barg)
10	(.69)	270	(18.6)	300	(20.7)	0.23	0.57	0.87	10–50	(.69–3.4)
15	(1.0)	405	(27.9)	415	(28.6)	0.27	0.59	0.95	10–50	(.69–3.4)
20	(1.4)	540	(37.2)	420	(29.0)	0.31	0.61	1.03	10–50	(.69–3.4)
25	(1.7)	670	(46.2)	425	(29.3)	0.36	0.63	1.12	10–50	(.69–3.4)
35	(2.4)	685	(47.2)	435	(30.0)	0.44	0.66	1.28	10–50	(.69–3.4)
50	(3.4)	740	(51.0)	450	(31.0)	0.63	1.21	1.67	40–80	(2.8–5.5)
75	(5.2)	740	(51.0)	475	(32.8)	0.83	1.52	2.03	65–100	(4.5–6.9)
100	(6.9)	740	(51.0)	500	(34.5)	1.24	2.10	2.45	80–150	(5.5–10.3)
125	(8.6)	740	(51.0)	525	(36.2)	1.32	2.18	2.52	80–150	(5.5–10.3)
150	(10.3)	740	(51.0)	550	(37.9)	1.12	1.99	2.52	120–300	(8.3–20.7)
175	(12.1)	740	(51.0)	575	(39.7)	1.20	2.06	2.52	120–300	(8.3–20.7)
200	(13.8)	740	(51.0)	600	(41.4)	1.28	2.13	2.52	120–300	(8.3–20.7)
250	(17.2)	740	(51.0)	650	(44.8)	1.37	2.21	2.52	120–300	(8.3–20.7)
300	(20.7)	740	(51.0)	700	(48.3)	1.45	2.29	2.52	120–300	(8.3–20.7)

METRIC CONVERSION FACTOR: Cv ÷ 1.16 = kv



TABLE 7  
Cv – FLOW CAPACITY

**OPT -12, 1-STEP REDUCED PORT – METAL DIAPHRAGM**

Based on 400 psid (27.6 Bard) max pressure drop limit for composition seat, and on 650 psid (44.8 Bard) for metal seat.

$(F_L = 0.93)$

METAL DIAPHRAGM – SIZE – 3/4" (DN20) – 1-STEP REDUCED PORT										
Outlet Pressure		Max Inlet Pressure				Cv @ % DROOP			Range Spring	
		Metal Seated		Composition Seated						
psig	(Barg)	psig	(Barg)	psig	(Barg)	10%	20%	30%	psig	(Barg)
10	(.69)	190	(13.1)	325	(22.4)	0.42	0.81	1.18	10-40	(.69-2.8)
15	(1.0)	295	(20.3)	415	(28.6)	0.47	0.89	1.27	10-40	(.69-2.8)
20	(1.4)	395	(27.2)	420	(29.0)	0.53	0.98	1.37	10-40	(.69-2.8)
25	(1.7)	500	(34.5)	425	(29.3)	0.58	1.04	1.45	10-40	(.69-2.8)
35	(2.4)	685	(47.2)	435	(30.0)	0.67	1.18	1.62	30-60	(2.1-4.1)
50	(3.4)	740	(51.0)	450	(31.0)	0.88	1.52	2.01	30-60	(2.1-4.1)
75	(5.2)	740	(51.0)	475	(32.8)	1.03	1.78	2.34	55-110	(3.8-7.6)
100	(6.9)	740	(51.0)	500	(34.5)	1.59	2.58	3.50	55-110	(3.8-7.6)
125	(8.6)	740	(51.0)	525	(36.2)	1.72	2.69	3.50	90-150	(6.2-10.3)
150	(10.3)	740	(51.0)	550	(37.9)	1.40	2.48	3.45	120-300	(8.3-20.7)
175	(12.1)	740	(51.0)	575	(39.7)	1.49	2.56	3.50	120-300	(8.3-20.7)
200	(13.8)	740	(51.0)	600	(41.4)	1.58	2.64	3.50	120-300	(8.3-20.7)
250	(17.2)	740	(51.0)	650	(44.8)	1.67	2.72	3.50	120-300	(8.3-20.7)
300	(20.7)	740	(51.0)	700	(48.3)	1.77	2.88	3.50	120-300	(8.3-20.7)

METAL DIAPHRAGM – SIZE – 1" (DN25) – 1-STEP REDUCED PORT										
Outlet Pressure		Max Inlet Pressure				Cv @ % DROOP			Range Spring	
		Metal Seated		Composition Seated						
psig	(Barg)	psig	(Barg)	psig	(Barg)	10%	20%	30%	psig	(Barg)
10	(.69)	190	(13.1)	280	(19.3)	0.51	1.05	1.55	10-30	(.69-2.1)
15	(1.0)	290	(20.0)	415	(28.6)	0.57	1.17	1.74	10-30	(.69-2.1)
20	(1.4)	395	(27.2)	420	(29.0)	0.63	1.29	1.93	10-30	(.69-2.1)
25	(1.7)	495	(34.1)	425	(29.3)	0.68	1.29	1.93	10-30	(.69-2.1)
35	(2.4)	675	(46.6)	435	(30.0)	0.68	1.40	2.13	25-45	(1.7-3.1)
50	(3.4)	740	(51.0)	450	(31.0)	0.92	1.90	3.10	40-80	(2.8-5.5)
75	(5.2)	740	(51.0)	475	(32.8)	1.13	2.41	4.02	40-80	(2.8-5.5)
100	(6.9)	740	(51.0)	500	(34.5)	1.75	4.08	5.46	65-150	(4.5-10.3)
125	(8.6)	740	(51.0)	525	(36.2)	1.80	4.15	5.46	65-150	(4.5-10.3)
150	(10.3)	740	(51.0)	550	(37.9)	1.88	4.28	5.46	120-250	(8.3-17.2)
175	(12.1)	740	(51.0)	575	(39.7)	1.94	4.39	5.46	120-250	(8.3-17.2)
200	(13.8)	740	(51.0)	600	(41.4)	1.99	4.50	5.46	120-250	(8.3-17.2)
250	(17.2)	740	(51.0)	650	(44.8)	2.04	4.60	5.46	120-250	(8.3-17.2)
300	(20.7)	740	(51.0)	700	(48.3)	2.15	4.82	5.46	120-250	(8.3-17.2)

METRIC CONVERSION FACTOR:  $C_v \div 1.16 = k_v$

TABLE 7  
Cv – FLOW CAPACITY

**OPT -12, 1-STEP REDUCED PORT – METAL DIAPHRAGM**

Based on 400 psid (27.6 Bard) max pressure drop limit for composition seat, and on 650 psid (44.8 Bard) for metal seat.

$$(F_L = 0.93)$$

METAL DIAPHRAGM – SIZE – 1-1/2" (DN40) – 1-STEP REDUCED PORT										
Outlet Pressure		Max Inlet Pressure				Cv @ % DROOP			Range Spring	
		Metal Seated		Composition Seated		10%	20%	30%	psig	(Barg)
psig	(Barg)	psig	(Barg)	psig	(Barg)					
10	(.69)	185	(12.8)	255	(17.6)	0.78	1.55	2.42	10–50	(.69–3.4)
15	(1.0)	285	(19.7)	395	(27.2)	0.87	2.10	2.67	10–50	(.69–3.4)
20	(1.4)	385	(26.6)	420	(29.0)	0.96	1.92	2.93	10–50	(.69–3.4)
25	(1.7)	385	(26.6)	425	(29.3)	1.04	2.13	3.13	10–50	(.69–3.4)
35	(2.4)	660	(45.5)	435	(30.0)	1.21	2.54	3.53	10–50	(.69–3.4)
50	(3.4)	740	(51.0)	450	(31.0)	1.67	3.47	4.62	40-75	(4.1–5.2)
75	(5.2)	740	(51.0)	475	(32.8)	2.64	4.75	6.00	60-150	(4.1-10.3)
100	(6.9)	740	(51.0)	500	(34.5)	2.72	4.84	6.00	60-150	(4.1-10.3)
125	(8.6)	740	(51.0)	525	(36.2)	2.80	4.93	6.00	60-150	(4.1-10.3)
150	(10.3)	740	(51.0)	550	(37.9)	2.88	5.02	6.00	60-150	(4.1-10.3)

METAL DIAPHRAGM – SIZE – 2" (DN25) – 1-STEP REDUCED PORT										
Outlet Pressure		Max Inlet Pressure				Cv @ % DROOP			Range Spring	
		Metal Seated		Composition Seated		10%	20%	30%	psig	(Barg)
psig	(Barg)	psig	(Barg)	psig	(Barg)					
10	(.69)	165	(11.4)	165	(11.4)	1.75	3.27	4.82	10–30	(.69–2.1)
15	(1.0)	265	(18.3)	265	(18.3)	2.04	3.79	5.42	10–30	(.69–2.1)
20	(1.4)	365	(25.2)	365	(25.2)	2.33	4.30	6.01	10–30	(.69–2.1)
25	(1.7)	460	(31.7)	425	(29.3)	2.62	4.82	6.61	10–30	(.69–2.1)
35	(2.4)	530	(36.6)	435	(30.0)	3.75	6.53	8.70	25-45	(1.7–3.1)
50	(3.4)	700	(48.3)	450	(31.0)	4.15	7.15	9.10	35-90	(2.4–6.2)
75	(5.2)	740	(51.0)	475	(32.8)	5.30	8.75	10.30	35-90	(2.4–6.2)
90	(6.2)	740	(51.0)	500	(34.5)	5.99	8.40	10.57	35-90	(2.4–6.2)

METRIC CONVERSION FACTOR:  $C_v \div 1.16 = k_v$

## DIMENSIONS AND WEIGHTS

Size Inches	DIMENSIONS - ENGLISH -Inches						Approx. Weight Lbs.
	A	B	C	D	E	F	
1/2"	5.94	10.00	1.62	5.62	3.75	3.94	8
3/4"	7.12	11.25	1.75	6.56	3.81	4.00	28
1"	7.94	11.75	2.12	7.38	4.38	4.69	37
1-1/2"	9.75	15.75	2.50	9.12	6.19	5.75	77
2"	11.25	16.00	2.88	11.25	7.06	6.62	109
Size (DN)	DIMENSIONS - METRIC (mm)						Approx. Weight Kgs.
	A	B	C	D	E	F	
(15)	(151)	(254)	(41)	(143)	(95)	(100)	4
(20)	(181)	(286)	(44)	(167)	(97)	(102)	13
(25)	(202)	(298)	(54)	(187)	(111)	(119)	17
(40)	(248)	(400)	(64)	(232)	(157)	(146)	35
(50)	(286)	(406)	(73)	(286)	(179)	(168)	49

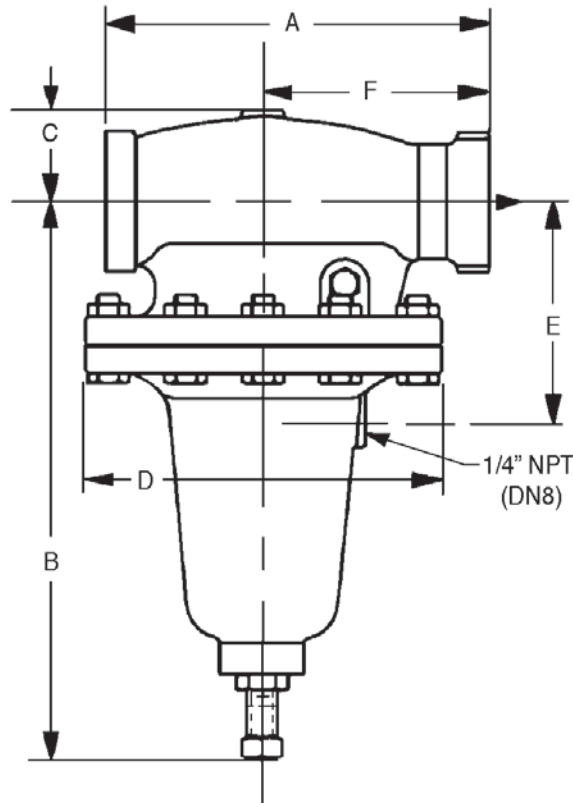

The contents of this publication are presented for informational purposes only, and while every effort has been made to ensure their accuracy, they are not to be construed as warranties or guarantees, express or implied, regarding the products or services described herein or their use or applicability. We reserve the right to modify or improve the designs or specifications of such product at any time without notice.

Cashco, Inc. does not assume responsibility for the selection, use or maintenance of any product. Responsibility for proper selection, use and maintenance of any Cashco, Inc. product remains solely with the purchaser.

# MODEL 1000HP Cryogenic PRODUCT CODER 12/05/14

An "X" in POS 12 followed by a 5-digit control number overrides remaining selections.

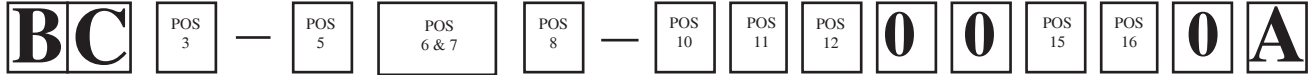

POSITION 3 - SIZE & SERVICE			
Size		Service	
In	(DN)	Gaseous	Liquid
		CODE	CODE
1/2"	(15)	4	J
3/4"	(20)	5	K
1"	(25)	6	L
1-1/2"	(40)	8	N
2"	(50)	9	P

POSITION 5 - BODY & SPRING CHAMBER. MATERIALS		
Body/Sp.Ch.	Option	CODE
BRZ/BRZ	- 5 *	3
SST/SST	- 36 *	A
CS/CS (LCC)	**	D

\* Cleaned per Spec #S-1134 (Opt. -55)  
\*\* Minimum temperature -50° F (-46° C)

POSITION 6 & 7 - TRIM DESIGNATION			
Brass Trim (For Brass Body)		Stainless Steel Trim (For SST & CS Body)	
Desig.	CODE	Desig.	CODE
B5	B5	S1	S1
		S36	36
		S40B *	4B
		S40C *	4C

\* NACE Trim Min. Temperature -50° F (-46° C), use w/ CS (LCC) code "D" in Position 3.

POSITION 8 - Product Classification Under European "Pressure Equipment Directive"		
PRODUCT DESTINATION	HAZARD CATEGORY	CODE
Anywhere except Europe	N/A	7
European Countries * (CE Mark does not apply to DN25 and below)	Sound Engineering Practice (SEP)	S
	CE Marked Hazard Cat I or II	E

\* For products to be placed in service in Europe - Ref to Directive 97/23/EC. Forward Completed "EU" Application Recorder prior to quotation. (Without Recorder- Processing of Purchase Order will be delayed). Contact Cashco for Assistance.

POSITION 10 - END CONNECTIONS	
Description	CODE
NPT - Screwed	1
-30 Opt. - 150 LB RF Figs. *	6
-30 Opt.- 300 LB RF Figs. *	7

\*Nipples & flanges of same material as body. CS or SST Body material only.

POSITION 11 - SST RANGE SPRINGS							
SIZE	PSIG	(BARG)	CODE	SIZE	PSIG	(BARG)	CODE
1/2" (DN15)	10-50	(.69-3.4)	3	1-1/2" (DN40)	10-50	(.69-2.1)	3
	40-80	(2.8-5.5)	B		40-75	(2.8-5.2)	A
	65-100	(4.5-6.9)	G		60-150	(4.1-10.3)	F
	80-150	(5.5-10.3)	J	2" (DN50)	10-30	(.69-2.1)	1
	120-300	(8.3-20.7)	N		25-45	(1.7-3.1)	5
3/4" (DN20)	10-40	(.69-2.8)	2	35-90	(2.4-6.2)	9	
	30-60	(2.1-4.1)	6				
	50-70	(3.4-4.8)	C				
	55-110 (	3.8-7.6)	E				
	90-150	(6.2-10.3)	K				
1" (DN 25)	120-300	(8.3-20.7)	N				
	10-30	(.69-2.1)	1				
	25-45	(1.7-3.1)	5				
	35-50	(2.4-3.4)	8				
	40-80	(2.8-5.5)	B				
	65-150	(4.5-10.3)	H				
	120-250	(8.3-17.2)	M				

POSITION 12 - TRIM VARIATIONS						
Description	For BRZ Body Material		* For SST or CS Body Material			
	Option	CODE	Option	CODE	W/ -17 Opt.	
					Option	CODE
No Special Trim Variation	--	0	--	0	--	--
Reduced Orifice (One-Step)	--	--	-12	A	-12+17	1
Integral Seat Surface	Std	0	-14	C	-14+17	3
Reduced Orifice & Integral Seat	-12+14**	E	-12+14	E	-12+14+17	5
Piston Spring	Std	0	-17	H	-17	H
For Special Construction Contact Cashco for Special Product Code	SPQ			X		

\* Option -14 or -17 or any combination of - not available with Nace Trim selection..  
\*\* Integral Seat Standard for Brass body / B5 Trim

POSITION 15 - BODY OPTIONS		
Description	Option	CODE
No Option	-	0
1/4" (DN8) NPT Drain Hole/Press. Tap (No Gauge).	-26	F

POSITION 16 - CERTIFICATE OPTIONS		
Description	Option	CODE
No Option	-	0
NACE Const.: CS/CS/S40B or S40C Per MR0175 (CODE "D" Position 3.	-40	J

Cashco, Inc.  
P.O. Box 6  
Ellsworth, KS 67439-0006  
PH (785) 472-4461  
Fax. # (785) 472-3539  
www.cashco.com  
email: sales@cashco.com  
Printed in U.S.A. 1000HP-CRYO-TB

Cashco GmbH  
Handwerkerstrasse 15  
15366 Hoppegarten, Germany  
PH +49 3342 4243135  
Fax. No. +49 3342 4243136  
www.cashco.com  
email: germany@cashco.com

Cashco do Brasil, Ltda.  
Al.Venus, 340  
Indaiatuba - Sao Paulo, Brazil  
PH +55 11 99677 7177  
Fax. No.  
www.cashco.com  
email: brazil@cashco.com