

# Valve Positioners and Volume Boosters

## Series 73 Built-In Valve Positioner

### Introduction

#### Features & Benefits

- ▶ Single-axis, force-balance principle of operation, ensures accurate and stable positioning
- ▶ Feedback circuits direct the actuator's position, ensuring adherence to the control instrument signal
- ▶ Range spring capability accommodates a wide variety of valve strokes and instrument spans

#### Description

The Moore Series 73 Built-in Valve Positioners use the full force of their air supply to drive and maintain the piston or diaphragm in a pneumatic actuator to position a valve to what is required by a control instrument, regardless of the presence of forces that change valve position.

This line of compact instruments incorporates a single-axis, force-balance principle of operation to ensure accurate and stable control valve positioning. In all cases, including bottom-loading applications, a Model 73 Built-In Valve Positioner is mounted directly on the topwork of the valve, with no external levers or other exposed mechanisms.

Each positioner receives a signal from a control instrument, and using an air supply as high as 100 psig, the positioner strokes the valve actuator to the required position.

Like all valve positioners, the Model 73 Built-In Valve Positioners have feedback circuits designed to measure the position of the actuator's piston or diaphragm. The positioner then supplies or exhausts air to bring the actuator within the required range for its corresponding control instrument.

The position of the piston or diaphragm in the valve actuator is sensed by the amount of compressive force exerted by a range spring on the valve positioner's diaphragm assembly. By selecting the appropriate range spring from the wide selection available almost any combination of valve stroke (from 1/4" to 4") and instrument span (from 2 to 24 psi) can be obtained.

#### Specifications

Functional Specifications

##### Input Range

3-15, 3-9, 9-15, 6-30, 3-27 psig

##### Valve Travel

Minimum: 1/4"  
Maximum: 4"

##### Supply Pressure

Minimum: 3 psi above required actuator pressure  
Maximum: 100 psig



#### Air Consumption

(In balance condition with 20 psig supply and 9 psig dead-ended output)

- 73N\_F: 0.25 scfm
- 73N\_B: 0.6 scfm

#### Overrange Limit

150 psig to any connection

#### Response Level

(output sensitivity to input pressure changes)

- 73N\_F: 0.1% of input span
- 73N\_B: 0.25% of input span

Functional Mechanical

#### Materials of Construction

Aluminum, brass, stainless steel, Neoprene®, and/or Buna-N

#### Model Selection

Model	Type of Application
73N12F	Top-loading, direct-acting, input spans of 2 to 12 psi
73N24F	Top-loading, direct-acting, input spans over 12 to 24 psi
73N-FR	Top-loading, reverse-acting
73N-B	Bottom-loading, direct-acting
73N-B1	Bottom on actuators w/actuator range spring

# Valve Positioners and Volume Boosters

## Series 73 Built-In Valve Positioner

### Technical data

#### Spring Table

Valve Stroke Inches	Instrument Input Pressure Span (PSI)								
	4	5	6	8	10	12	16	20	24
	- Item No. of Range Spring Series 12395 Series $\pm 10\%$ Stroke Range Tolerance) Example: 12395-1212								
1/4	1212	1012	812	612	512	412	624	524	424
5/16	1612	1212	1012	712	612	512	824	624	524
3/8	1812	1412	1212	1012	712	612	1024	724	624
7/16	2012	1812	1412	1012	812	712	1024	824	724
1/2	2412	2012	1612	1212	1012	812	1224	1024	824
9/16	2812	2012	1812	1412	1012	1012	1424	1024	
5/8	3212	2412	2012	1612	1212	1012	1624	1224	1024
3/4	3612	2812	2412	1812	1412	1212		1464	1224
7/8	4412	3612	2812	2012	1812	1412	2024	1624	1424
1	4812	4012	3212	2412	2012	1612	2424	2024	1624
1-1/8	5612	4412	3612	2812	2012	1812		2024	
1-1/4	6412	4812	4012	3212	2412	2012	2824	2424	2024
1-1/2	80	6412*	4812	3612	2812	2412	4024	2824	2424
1-5/8	80	6412*	4812	4012	3212	2612	4024	3224	
1-3/4	80	6412*	5612	4412	3612	2812	4024	3224	2824
2	100	80	6412*	4812	4012	3212	4824	4024	3224
2-1/4	100	80	80	5612	4412	3612		4024	
2-1/2	126	100	80	6412*	4812	4012		4824	4024
2-3/4	126	100	80	6412*	4812	4412		4824	4824
3		126	100	80	6412*	4812			4824
3-1/2						5612			
4						6412*			
	- Item No. of Range Spring Series 4090 Series ( $\pm 10\%$ Stroke Range Tolerance) Example: 4090-80								

- 1) The maximum zero pressure for Model 73N12F is 9 psig when the 12388 or 12395 series range spring is used. The maximum is 20 psig when the 4090 series range spring is used.
- 2) The maximum zero pressure for Model 73N24F is 15 psig for instrument pressure spans of 16 psi or greater, and 28 psig when used for spans of 12 psi or less.
- 3) The maximum instrument pressure for Model 73N-FR is 15 psig for instrument pressure spans of 12 psi or less, and 27 psi for spans of 16 psi or greater.

#### Mounting Dimensions

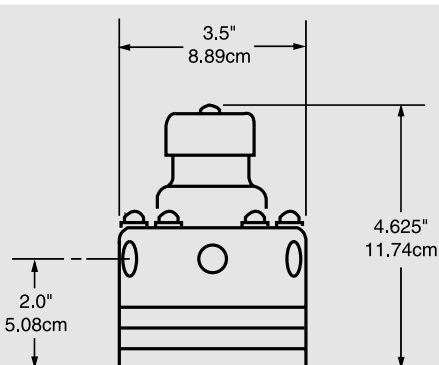

The topworks of the valve must have six, 1/4-20 x 9/16 deep (min.) blind tapped, equally spaced holes for mounting positioner

#### LIMITATIONS ON USE OF RANGE SPRING SERIES 4090

Range Spring 4090-	Max. Nom. Stroke (Inches)	Max. Nom. Span (psi)	Max. Inst. Air Press. (psi)
80	3	8	8.0
100	3	6	6.5
126	3	5	5.0

#### Spring Selection

1. Find the valve stroke nearest the desired valve stroke.
  2. Find the instrument input pressure span nearest the desired instrument input pressure span.
  3. Select the proper range spring at the intersection of the valve stroke and the instrument input pressure span columns.
- For additional information on range spring selection, request AD73.